



**SRM VALLIAMMAI ENGINEERING COLLEGE**

**(An Autonomous Institution)**

SRM Nagar, Kattankulathur– 603203



**DEPARTMENT OF MECHANICAL ENGINEERING**

**QUESTION BANK**



**I & II SEMESTER**

**1901007 - ENGINEERING GRAPHICS**

**Regulation - 2019**

**Academic Year 2022-2023 (Odd and Even Semester)**

*Prepared by*

**Mr.T.Muthu Krishnan, M.E., (Ph.D.) Assistant Professor (O.G) / Mechanical**

**All Questions (1 x 20 = 20 Marks)**

**UNIT I - PLANE CURVES AND SPECIAL CURVES**

Basic Geometrical constructions, Curves used in engineering practices: Conics – Construction of ellipse, parabola and hyperbola by eccentricity method – Construction of cycloid (Rolling Circle rolls on flat surface only). construction of involutes of square and circle – Drawing of tangents and normal to the above curves.

Q.No	Questions	BT Level	Competence
1	Construct a parabola when the distance between the focus and directrix is 50 mm. Also, draw the tangent and normal to any point on the curve.	BTL-6	Create
2	Construct a hyperbola when the distance between the focus and directrix is 45 mm and eccentricity is $5/4$ . Also, draw the tangent and normal to any point on the curve.	BTL-6	Create
3	Construct an ellipse when the distance between the focus and directrix is 50 mm and eccentricity is $2/3$ . Also, draw the tangent and normal to any point on the curve	BTL-6	Create
4	Draw the locus of a point P which moves in a plane in such a way that the ratio of its distances from a fixed-point F and fixed straight-line $DD^1$ is always $2/3$ . The distance between the fixed-point F and the fixed straight line is 50 mm. also draw a tangent and normal on a point on the locus at a horizontal distance of 40 mm from the fixed straight line.	BTL-6	Create
5	Construct a cycloid given the radius of the generating circle is 30 mm. Also, draw a tangent and normal at any point on the cycloid.	BTL-6	Create
6	Construct a cycloid for one and a half revolutions when the radius of the generating circle is 25 mm.	BTL-6	Create
7	Coir is unwound from a drum of 50 mm diameter. Draw the locus of the free end of the coir for unwinding through an angle of $360^\circ$ . Also, draw normal and tangent at any point on the curve.	BTL-6	Create
8	(i) Draw the involute of a circle of diameter 40 mm. (15)	BTL-6	Create
	(ii) Draw the involute of a square of base side 30 mm. (5)	BTL-6	Create
9	A roller of 60 mm diameter rolls over a horizontal table without slipping for one complete rotation, Draw the path traced by the point P on the circumference of the circle. Also, draw a tangent and normal at any point on the curve.	BTL-6	Create
10	A circle of 60 mm diameter rolls over a horizontal line clockwise for $1\frac{1}{2}$ revolution. Draw the path traced by the point P on the circumference of the circle. Also, draw a tangent and normal at any point on the curve.	BTL-6	Create
11	A circle of 50 mm diameter rolls over a horizontal roof in an anticlockwise	BTL-6	Create

direction for one complete revolution. Draw the path traced by the point P on the circumference of the circle. Also, draw a tangent and normal at any point on the curve.

- |    |  |       |        |
|----|--|-------|--------|
| 12 | Construct an ellipse when the distance between the focus and directrix is 35 mm and eccentricity is $\frac{3}{4}$ . Also draw the tangent and normal to any point on the curve.  | BTL-6 | Create |
| 13 | Construct a Parabola when the distance between the focus and directrix is 40 mm and eccentricity is 1. Also, draw the tangent and normal to any point on the curve.  | BTL-6 | Create |
| 14 | Construct a parabola when the distance between the focus and directrix is 1000 mm. Also, draw the tangent and normal to any point on the curve. Use a suitable scale to draw the curve.                                    | BTL-6 | Create |
| 15 | Construct a hyperbola when the distance between the focus and directrix is 450 mm and eccentricity is $\frac{5}{4}$ . Also, draw the tangent and normal to any point on the curve. Use a suitable scale to draw the curve. | BTL-6 | Create |
| 16 | Construct a cycloid given the radius of the generating circle is 150 mm. Also, draw a tangent and normal at any point on the cycloid. Use a suitable scale to draw the curve.  | BTL-6 | Create |
| 17 | Construct an ellipse when the distance between the focus and directrix is 1200 mm and eccentricity is $\frac{2}{3}$ . Also, draw the tangent and normal to any point on the curve. Use a suitable scale to draw the curve. | BTL-6 | Create |
| 18 | Construct an involute of a circle of diameter 200 mm. Also, draw a tangent and normal at any point on the involute. Use a suitable scale to draw the curve.  | BTL-6 | Create |

## UNIT II- PROJECTION OF POINTS, LINES AND PLANE SURFACES

Orthographic projection- Principles-Principal planes-First angle projection-projection of points at First

Quadrant only. Projection of straight lines (only First angle projections) inclined to both the principal planes –Determination of true lengths and true inclinations by rotating line method. Projection of planes (polygonal and circular surfaces) inclined to both the principal planes by rotating object method.

Q.No	Questions	BT Level	Competence
1	Draw the projection of the following points. Give 30mm space between each projector with proper dimensions. A is 35 mm above HP and 45 mm in front of VP. (5) B is 40 mm above HP. and in VP. (5) C is in HP and 45 mm in front of VP. (5) D is in both HP and VP. (5)	(BT-6)	Create
2	(i) A line AB 60 mm long has its end A 20 mm above HP and 30 mm in front of VP. The line is kept inclined at $40^\circ$ to HP and parallel to VP. Draw its projections and do proper dimensions. (10)	(BT-6)	Create
	(ii) A line AB 60 mm long has its end A 20 mm above HP and 30 mm in front of VP. The line is inclined at $40^\circ$ to VP and parallel to HP. Draw its projections. (10)	(BT-6)	Create
3	(i) A line AB 70 mm long has its end A 15 mm above HP and 25 mm in front of VP. Its top view (plan) has a length of 40 mm. draw its projections and find the inclination of the line with HP. (10)	(BT-6)	Create
	(ii) A line AB has its end A 20 mm above HP and 15 mm in front of VP. Its front view (elevation) has a length of 35 mm. Draw the projections and find the inclination of the line with VP. (10)	(BT-6)	Create
4	A line AB 80 mm long has its end A 20 mm above HP and 25 mm in front of VP. The line is inclined at $45^\circ$ to HP and $35^\circ$ to VP. Draw its projections. (BT-6)	(BT-6)	Create
5	One end A of line AB, 75 mm long is 20 mm above HP and 25 mm in front of VP. The line is inclined at $30^\circ$ to HP and the top view makes $45^\circ$ VP. Draw the projection of the line and find the inclinations with the vertical plane. (BT-6)	(BT-6)	Create
6	A line AB 75 mm long has its end A in both HP and VP. The line is kept inclined at $45^\circ$ to HP and $30^\circ$ to VP. Draw its projections. (BT-6)	(BT-6)	Create
7	A line AB 70 mm long, has its end A 35 mm above HP and 30 mm in front of VP. The top view and front view have a length of 45 mm and 60 mm respectively. Draw its projections. (BT-6)	(BT-6)	Create
8	The mid-point of a straight line AB 90 mm long is 60 mm above HP and 50 mm in front of VP. It is inclined at $30^\circ$ to HP and $45^\circ$ to VP. Draw its projections. (BT-6)	(BT-6)	Create
9	A front view of a line AB 90 mm long is inclined at $45^\circ$ to XY line. The front view measures 65 mm long. Point A is located 15 mm above HP and is in VP. Draw the projection and find its true inclinations. (BT-6)	(BT-6)	Create

- 10 A room is 4.8 m x 4.2 m x 3.6 m high. Determine graphically, the distance between a top corner and the bottom corner diagonally opposite to it. (BT-6) Create
- 11 (i) A pentagonal plate of side 30 mm is placed with one side on HP and the surface inclined at  $50^\circ$  to HP perpendicular to VP. Draw its projections. (10) (BT-6) Create
- (ii) A circular plate of diameter 50 mm is resting on HP on a point on the circumference with its surface inclined at  $45^\circ$  to HP and perpendicular to VP. Draw its projections. (10) (BT-6) Create
- 12 Draw the projection of a pentagonal plate whose side is 30 mm long, which is rest on HP by one of its edges and is inclined at  $45^\circ$  to VP. The surface of the plate is inclined at  $30^\circ$  to HP. (BT-6) Create
- 13 Draw the projection of a hexagonal plate whose side is 30 mm long, which is rest on HP by one of its edges and is inclined at  $45^\circ$  to VP. The surface of the plate is inclined at  $30^\circ$  to HP. (BT-6) Create
- 14 A rectangular plate of side 50 x 25 mm has its shorter side in HP and is inclined at an angle of  $30^\circ$  to the VP. The surface of the plate is inclined at an angle  $60^\circ$  to HP. Draw its projections. (BT-6) Create
- 15 A hexagonal lamina of side 30 mm rests on one of its sides on VP and is inclined at  $40^\circ$  to HP. Its surface is inclined  $35^\circ$  to VP. Draw its projection. (BT-6) Create
- 16 A square plate ABCD of side 30 mm is resting on HP on one of its corners and the diagonal AC inclined at  $30^\circ$  to HP. The diagonal BD of the plate is inclined at  $45^\circ$  to the VP and parallel to the HP. Draw its projections. (BT-6) Create
- 17 A pentagonal lamina of side 30 mm rests on one of its corners on HP the edge opposite to the resting corner is inclined at  $45^\circ$  to VP. The surface of the lamina is inclined to HP such that the edge opposite to the resting corner is 35 mm above HP. Draw its projection. (BT-6) Create
- 18 A circular lamina of diameter 50 mm is resting on the HP at a point on the circumference. Its surface is kept inclined at  $45^\circ$  to HP. Draw its projections when the line representing its diameter and passing through the resting point is inclined at  $30^\circ$  to the VP. (BT-6) Create

### UNIT III - PROJECTION OF SOLIDS AND ISOMETRIC PROJECTION

Projection of simple solids like prisms, pyramids, cylinders and cone when the axis is Inclined to one of the principal planes by the rotating object method. Principles of isometric projection – isometric scale – Isometric projections of simple solids - Prisms, pyramids, cylinders, cones.

Q.No	Questions	BT Level	Competence
1	A hexagonal prism of the base side 30 mm and axis length 60 mm rests on the HP on one of its base edges with its axis inclined at $40^\circ$ to HP and parallel to the VP. Draw its projections.	BTL-6	Create
2	A pentagonal prism of the base side 30 mm and axis length 60 mm is resting on HP on one of its base corners with its axis inclined at $40^\circ$ to HP and parallel to the VP. Draw its projections when the base sides containing the resting corner are equally inclined to HP.	BTL-6	Create
3	A pentagonal pyramid with a base side of 30 mm and an axis length of 60 mm is resting on HP on one of the base corners with its axis parallel to VP. Draw its projections when the slant edge containing the resting corner is vertical	BTL-6	Create
4	A hexagonal pyramid with a base side of 30 mm and an axis length of 60 mm is resting on one of its base edges with the face containing the resting edge perpendicular to both HP and VP. Draw its projections.	BTL-6	Create
5	A square pyramid with a base side of 30 mm and an axis length of 60 mm is resting on HP on one of its base corners with its axis parallel to VP and inclined $50^\circ$ to HP. Draw its projections.	BTL-6	Create
6	A hexagonal pyramid of base side 30 mm and axis length 60 mm is resting on HP on one of its base corners with its axis inclined at $35^\circ$ to HP. The base sides containing the resting corner are equally inclined to HP. Draw its projections.	BTL-6	Create
7	A cylinder of base diameter 50 mm and axis length 70 mm is resting on HP on a point on the circumference of the base with its axis inclined at $50^\circ$ to HP and parallel to VP. Draw its projections	BTL-6	Create
8	A square pyramid with a base side of 30 mm and an axis length of 60 mm is suspended by means of a string from one of its base corners with its axis parallel to VP. Draw its projections.	BTL-6	Create
9	A pentagonal pyramid with a base side of 30 mm and an axis length of 60 mm is resting on HP on one of its triangular faces with its axis parallel to VP. Draw its projections.	BTL-6	Create
10	A cone with a base diameter of 50 mm and axis length of 60 mm is resting on HP at a point on the circumference of the base. Its base is inclined at $50^\circ$ to HP and perpendicular to VP. Draw its projections.	BTL-6	Create
11	A pentagonal prism of base 30 mm and axis length 60 mm is resting on HP on one of its rectangular faces with its axis perpendicular to VP. Draw its isometric projection.	BTL-6	Create

- |    |   |                |                  |
|----|---|----------------|------------------|
| 12 | A hexagonal pyramid with a base side of 35 mm and an axis height of 65 mm is resting on HP by its base, such that one of the base edges is perpendicular to VP with its axis parallel to VP. Draw its isometric Projections.  | BTL-6          | Create           |
| 13 | (i) Draw the isometric view of a cone of base diameter 50 mm and axis length 60 mm resting on HP on its base. (10)<br>(ii) Draw the isometric view of a vertical cylinder with a base diameter of 50 mm and an axis length of 60 mm. (10)   | BTL-6<br>BTL-6 | Create<br>Create |
| 14 | (i) Draw the isometric view of the horizontal cylinder with a base diameter of 50 mm and an axis length of 60 mm. (10)<br>(ii) Draw the isometric view of a cone of base diameter 50 mm and axis length 60 mm placed in the horizontal position with its base perpendicular to HP and parallel to VP and near to it. (10) | BTL-6<br>BTL-6 | Create<br>Create |
| 15 | Draw the isometric view of a hexagonal pyramid with a base side of 30 mm and an axis length of 60 mm that is resting on its base.   | BTL-6          | Create           |
| 16 | A hexagonal prism of base side 30 mm and axis length 60 mm is resting on HP on its base with a side of base parallel to VP. Draw the isometric view of the prism.   | BTL-6          | Create           |
| 17 | Draw the isometric view of a pentagonal pyramid of the side of the base 30 mm and height of 70 mm, when it is resting on HP, such that an edge of the base is perpendicular to VP.  | BTL-6          | Create           |
| 18 | Draw the isometric view of a hexagonal prism of base side 30 mm and axis length 60 mm rests on HP on one of its rectangular faces with its axis perpendicular to VP.  | BTL-6          | Create           |



## UNIT IV - PROJECTION OF SECTIONED SOLIDS & DEVELOPMENT OF SURFACES

Sectioning of above solids in simple vertical position when the cutting plane is inclined to the one of the principal planes and perpendicular to the other – obtaining true shape of section. Development of lateral surfaces of simple and sectioned solids – Prisms, pyramids cylinders and cones.

Q.No	Questions	BT Level	Competence
1	A square prism of base side 30 mm and axis length 60 mm is resting on HP on one of its bases, with a base side inclined at $25^\circ$ to VP. It is cut by a plane inclined at $40^\circ$ to HP and perpendicular to VP and is bisecting the axis of the prism. Draw its front view, sectional top view and true shape of the section.	BTL-6	Create
2	A hexagonal prism of base 30 mm and axis 60 mm rests on its base on HP with its axis perpendicular to HP and one of the base edges is perpendicular to VP. The solid is cut by a plane that is perpendicular to VP, inclined at $50^\circ$ to HP and passing through a point at a distance of 12 mm from the top base. Draw the front view, sectional top view and true shape of the section.	BTL-6	Create
3	A square pyramid has a base side of 30 mm and an altitude of 60 mm. It rests with its base on HP such that one side of the base is inclined at $30^\circ$ to VP. The pyramid is cut by a plane that is inclined at $45^\circ$ to HP and perpendicular to VP and passes through the axis at a distance 25 mm from the apex. Draw the front view, sectional top view and true shape of the section.	BTL-6	Create
4	A cylinder with a base diameter of 50 mm and height 65 mm rests on its base on HP. It is cut by a plane perpendicular to VP and inclined at $30^\circ$ to HP and meets the axis at a distance of 30 mm from the base. Draw the front view, sectional top view and true shape of the section.	BTL-6	Create
5	A cone with a base diameter of 50 mm and an altitude of 75 mm rests on its base on the HP. It is cut by a plane inclined at $45^\circ$ to HP and perpendicular to VP and bisecting the axis. Draw the front view, sectional top view and true shape of the section.	BTL-6	Create
6	A hexagonal pyramid side of base 30 mm and altitude 70 mm rests with its base on HP and with a side of base parallel to VP. It is cut by a plane inclined at $35^\circ$ to HP, perpendicular to VP and bisecting the axis. Draw its top sectional view, front view and true shape of the section.	BTL-6	Create
7	A pentagonal pyramid of base side 30 mm and axis length 60 mm is resting on HP on its base with a side parallel to VP. It is cut by a plane inclined at $45^\circ$ to VP and perpendicular to HP and is 12 mm away from the axis. Draw its top view, sectional front view and true shape of the section.	BTL-6	Create
8	A cone with a base diameter of 60 mm and axis length of 70 mm is resting on HP	BTL-6	Create



on its base. It is cut by a plane perpendicular to VP and parallel to a contour generator and is 10 mm away from it. Draw the front view, sectional top view and true shape of the section.

- |    |  |       |        |
|----|--|-------|--------|
| 9  | A pentagonal pyramid of base side 20 mm and altitude 55 mm rests on its base on the HP with one of the base edges being perpendicular to VP. It is cut by a plane inclined $50^\circ$ to the base. The cutting plane meets the axis 15 mm above the base. Draw the front view, sectional top view, and true shape of the section.                    | BTL-6 | Create |
| 10 | A cube of 60 mm long edges has its vertical faces equally inclined to VP. It is cut by a sectional plane perpendicular to VP so that the true shape of the cut section is a regular hexagon. Locate the plane and determine the angle of inclination with respect to HP. Draw the sectional top view, front view and true shape of the section.      | BTL-6 | Create |
| 11 | A square prism of base side 30 mm and axis length 60 mm is resting on HP on one of its bases, with a base side inclined at $30^\circ$ to VP. It is cut by a plane inclined at $40^\circ$ to HP, perpendicular to VP and is bisecting the axis of the prism. Draw the development of the remaining portion of the prism.                              | BTL-6 | Create |
| 12 | A pentagonal prism of base side 30 mm and axis length 60 mm is resting on HP on its base with a side of base parallel to VP. It is cut by a plane inclined at $35^\circ$ to HP and perpendicular to VP and meets the axis at a distance of 35 mm from the base. Draw the development of the lower portion of the prism.                              | BTL-6 | Create |
| 13 | A hexagonal prism of base 30 mm and axis 60 mm is resting on HP on its base with two of its vertical faces perpendicular to VP. The solid is cut by a plane that is perpendicular to VP, inclined at $50^\circ$ to HP and passing through a point at a distance of 10 mm from the top end. Draw the development of the lateral surface of the prism. | BTL-6 | Create |
| 14 | A cone with a base diameter of 60 mm and a height of 80 mm rests on its base on the ground. An insect start from a point on the circumference of the base goes round the solid and reaches the starting point in the shortest path. Find the distance travelled by the insect and also the projections of the path followed by it.                   | BTL-6 | Create |
| 15 | A square pyramid has a base side of 30 mm and an altitude of 65 mm. It rests with its base on HP such that one side of the base is inclined at $25^\circ$ to VP. The pyramid is cut by a plane inclined at $35^\circ$ to HP and perpendicular to VP and bisects the axis. Draw the development of the remaining portion of the pyramid.              | BTL-6 | Create |
| 16 | A cylinder with a base diameter of 50 mm and a height of 70 mm rests on its base on the ground. A cutting plane inclined at $40^\circ$ to H.P. and meeting the axis 35 mm  | BTL-6 | Create |

from the base. Draw the development of the lower portion of the cylinder.

- 17 A pentagonal pyramid has a base side of 30 mm and an axis height of 60 mm. It rests with its base on HP such that one of the bases edges perpendicular to VP. It is cut by a plane perpendicular to VP and parallel to HP and meets the axis at a distance of 25 mm from the apex. Draw the development of the remaining portion of the pyramid. BTL-6 Create
- 18 A hexagonal pyramid with a base side of 30 mm and a height of 60 mm rests vertically on HP with one of the base sides parallel to VP. A string is wound around the surface of the pyramid from the left extreme point on the base and ends at the same point. Find graphically the shortest length of the string required. Also, trace the path of the string in the front and top views. BTL-6 Create



## UNIT V - FREE HAND SKETCHING AND PERSPECTIVE PROJECTIONS

Free Hand sketching: Visualization principles –Representation of Three-dimensional objects – Layout of views- Free hand sketching of multiple views from pictorial views of objects. Perspective projection of simple solids-Prisms and pyramids by visual ray method.

Q.No Questions

BT  
Level Competence  
BTL-6 Create

1 Draw the three orthographic views for the following fig.1

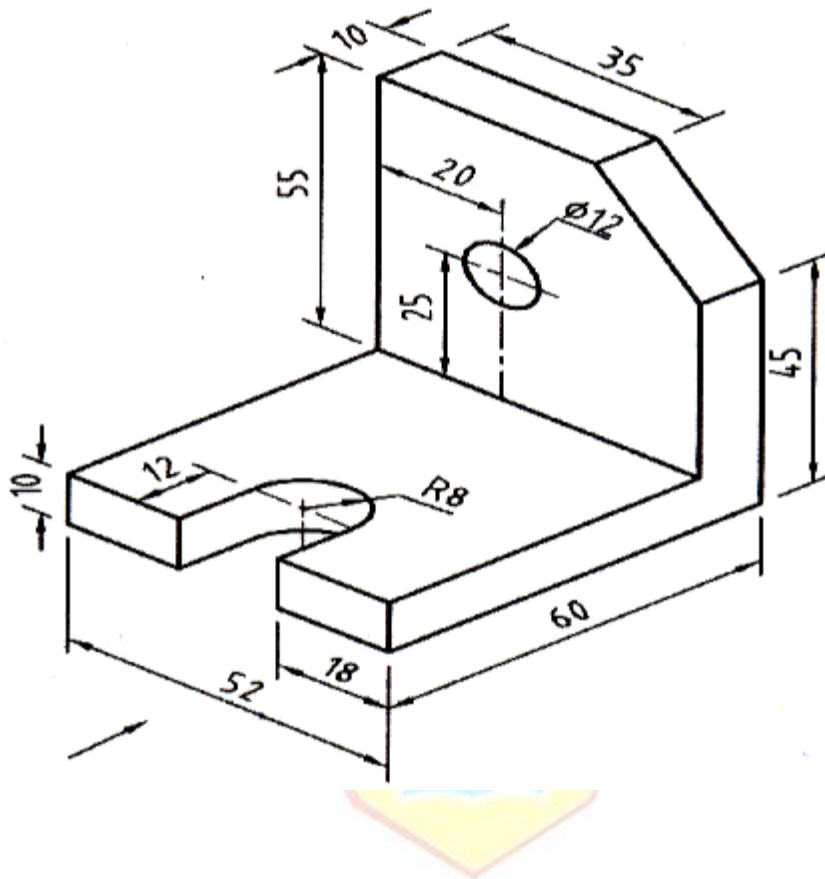

fig.1

2 Draw the three orthographic views for the following fig.2

BTL-6 Create

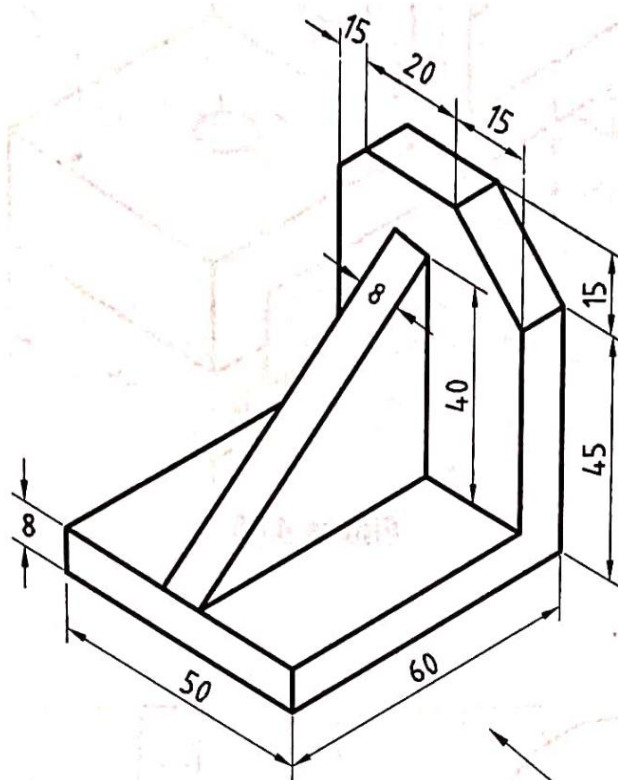

fig.2

3 Draw the front, top and side view of the given fig.3

BTL-6 Create

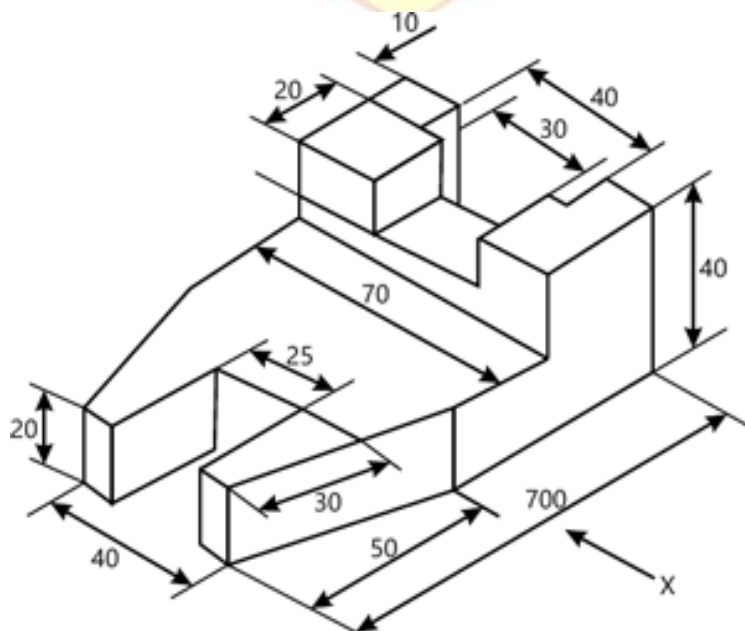

fig.3

4 Draw the three orthographic views for the following fig.4

BTL-6 Create

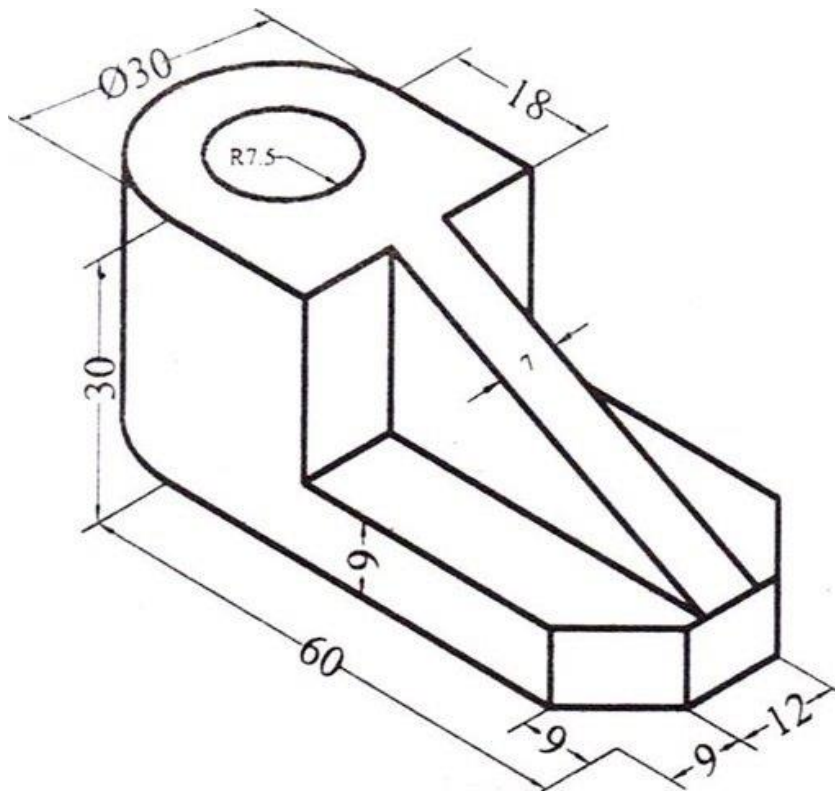

fig.4

5 Draw the three orthographic views for the following fig.5

BTL-6 Create

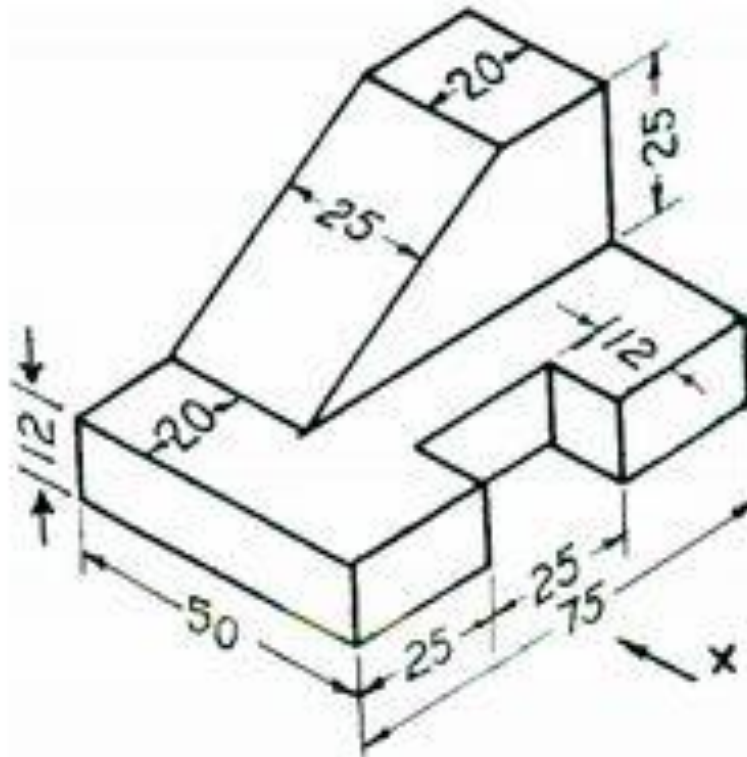

fig.5

6 Draw the front, top and left and right hand side view of the given fig.6

BTL-6 Create

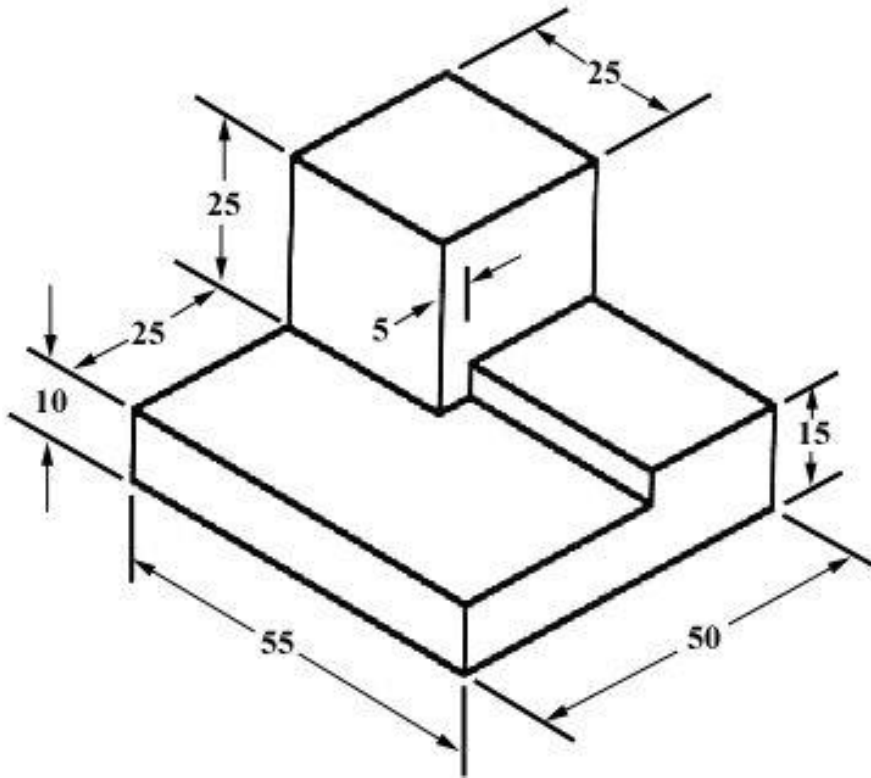

fig.6

7 Draw the front, top and left and right hand side view of the given fig.7

BTL-6 Create

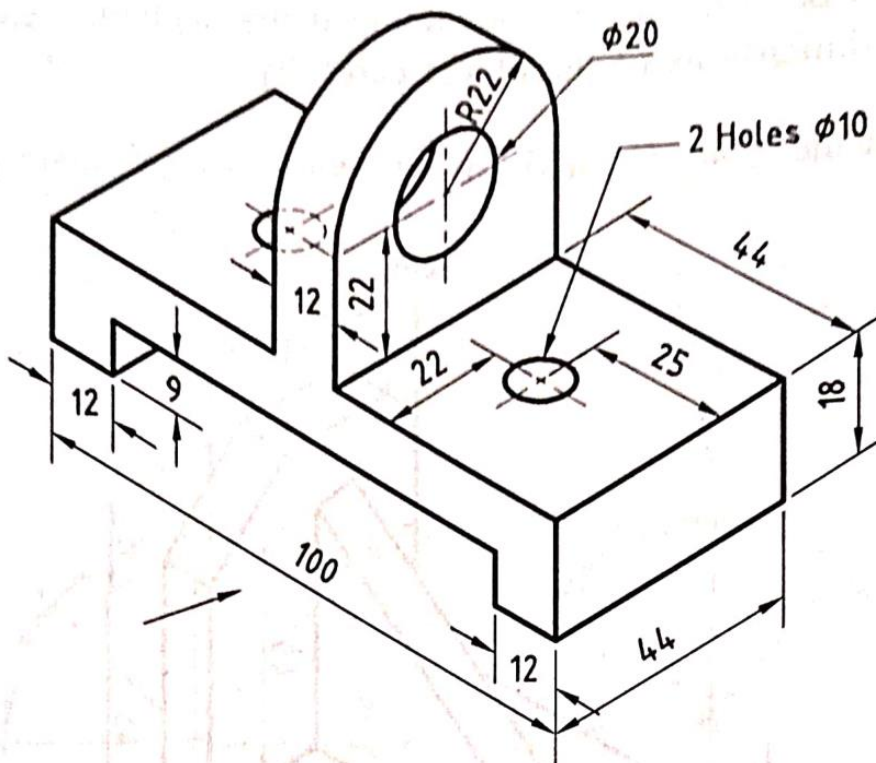

fig.7



8 Draw the front, top and left and right hand side view of the given fig.8

BTL-6 Create

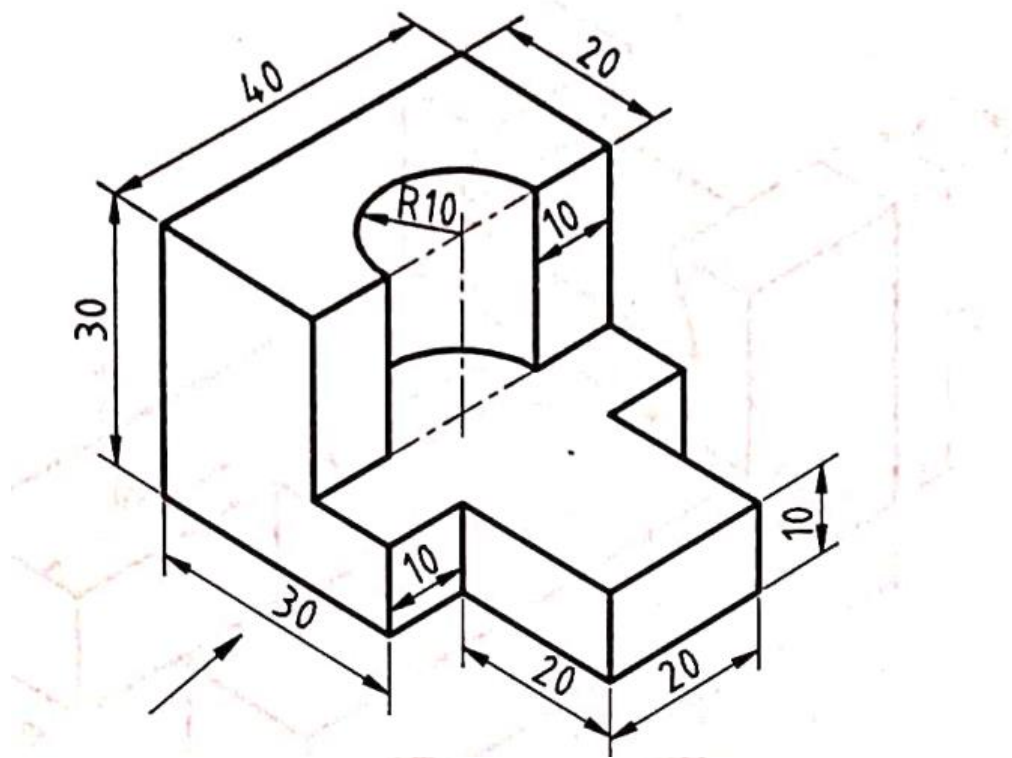

fig.8

9 Draw the front, top and left and right hand side view of the given fig.9

BTL-6 Create

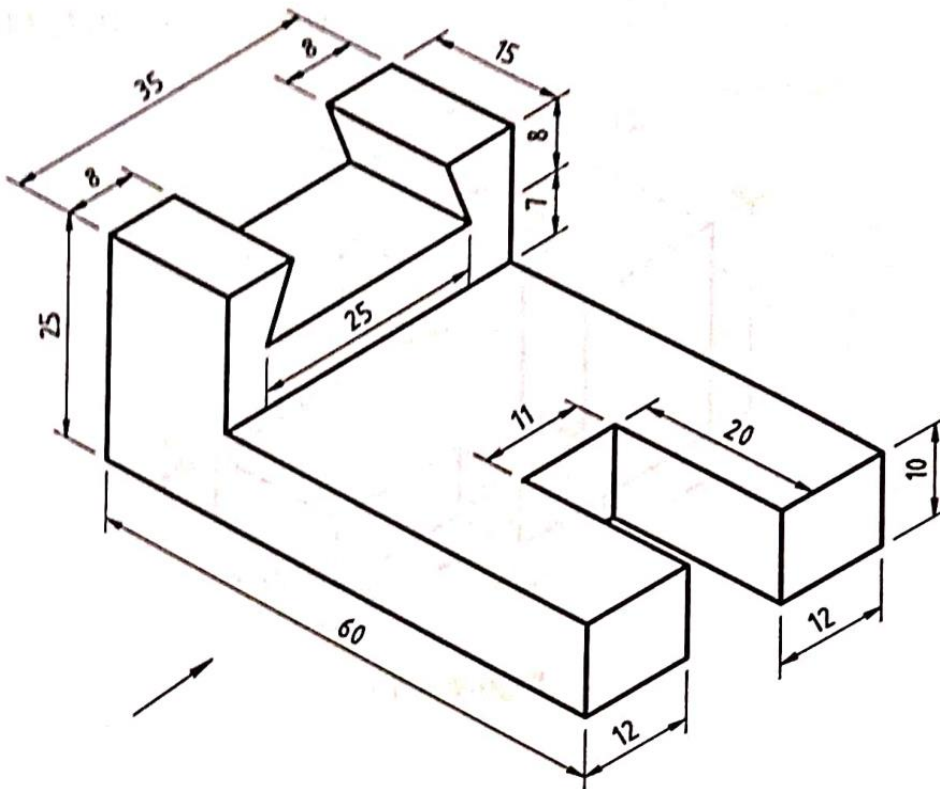

fig.9



10 Draw the front, top and left and right hand side view of the given fig.10

BTL-6 Create

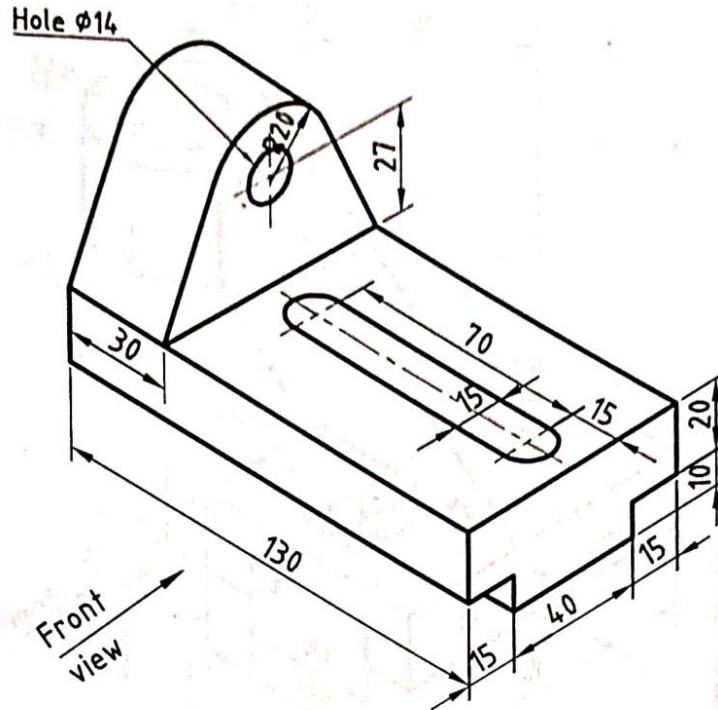

fig.10

11 A rectangle prism, with sides of a base of 50 mm x 30 mm and a height of 55 mm, rests with its base on the ground plane. A vertical edge is in the picture plane and one of the longer edges of its base is inclined at  $45^\circ$  to PP and behind it. The station point is 50 mm in front of PP, 75 mm above the ground plane, and lies in a central plane that passes through the center of the prism. Draw the perspective projection of the solid.

BTL-6 Create

12 Draw the perspective view of a square pyramid of base 30 mm side and height of apex 45 mm. the nearest edge of the base is parallel to and 20 mm behind the picture plane. The station point is situated at a distance of 70 mm in front of the PP and 40 mm to the right of the axis of the pyramid and 60 mm above the ground.

BTL-6 Create

13 Draw the perspective projection of a square prism of base sides 40 mm and height of 50 mm. One vertical lateral face is parallel to PP and 30 mm away from it. The station point is 80 mm from PP, 80 mm above the base and 60 mm to the right of the axis of the prism.

BTL-6 Create

14 Draw the perspective projection of a cube of 40 mm sides lying on one of its square faces on the ground and another square face on the picture plane. The station point is 45 mm in front of the picture plane, 50 mm above the ground and lies in a picture plane that is 65 mm to the right of the axis of the cube. Draw only the visible edges of the cube.

BTL-6 Create

- |    |  |       |        |
|----|--|-------|--------|
| 15 | A cylinder of base diameter 50 mm and axis length 50 mm is placed on GP on its base. The axis of the cylinder is 35 mm behind PP. The station point is 70 mm in front of PP and 70 mm above GP and is 50 mm to the left of the axis. Draw the perspective projection of the cylinder.  | BTL-6 | Create |
| 16 | A rectangular prism 30 x 50 x 70 is placed on the ground behind the picture plane with the longest edges vertical to GP and a longer base edge receding to the left at an angle of $40^{\circ}$ to the picture plane. The nearest vertical edge is on the picture plane and 15 mm to the left of the observer who is at a distance of 60 mm in front of the picture plane. The height of the observer above the ground is 90 mm. Draw the perspective view of the prism. | BTL-6 | Create |
| 17 | A regular hexagonal pyramid with a base edge of 20 mm and a height of 35 mm rests on its base on the ground plane with one of its base edges touching the picture plane. The station point is 30 mm above the ground plane and 40 mm in front of the PP. The central plane is 30 mm to the right of the axis. Draw the perspective projection of the pyramid.  | BTL-6 | Create |
| 18 | A regular pentagonal prism with a base edge of 20 mm and a height of 40 mm rests on its base on the ground plane with one of its base edges 20 mm behind the picture plane. The station point is 60 mm above the ground plane and 40 mm in front of the PP. The central plane is 45 mm to the right of the axis. Draw the perspective projection of the prism.   | BTL-6 | Create |

