

**SRM VALLIAMMAI ENGINEERING COLLEGE**  
(An Autonomous Institution)  
KATTANKULATHUR, CHENNAI-603203

**DEPARTMENT OF ELECTRONICS AND INSTRUMENTATION  
ENGINEERING**



**1901208: ENGINEERING PRACTICES LABORATORY**  
(ELECTRONICS ENGINEERING PRACTICE)

**II SEMESTER B.E/B.TECH**

(Common to all branches)

2019-2020 EVEN SEM

# LABORATORY PRACTICE

## SAFETY RULES

1. SAFETY is of paramount importance in the Laboratories.
2. Electricity NEVER EXECUSES careless persons. So, exercise enough care and attention in handling electrical & electronic equipment and follow safety practices in the laboratory. (Electricity is a good servant but a badmaster).
3. Avoid direct contact with any voltage source and power line voltages. (Otherwise, any such contact may subject you to electricalshock)
4. Wear rubber-soled shoes. (To insulate you from earth so that even if you accidentally contact a live point, current will not flow through your body to earth and hence you will be protected from electricalshock).
5. Wear laboratory-coat and avoid loose clothing. (Loose clothing may get caught on an equipment/instrument and this may lead to an accident particularly if the equipment happens to be a rotatingmachine)
6. Girl students should have their hair tucked under their coat or have it in aknot.
7. Do not wear any metallic rings, bangles, bracelets, wristwatches and neck chains. (When you move your hand/body, such conducting items may create a short circuit or may touch a live point and thereby subject you to electricalshock)
8. Be certain that your hands are dry and that you are not standing on wet floor. (Wet parts of the body reduce the contact resistance thereby increasing the severity of theshock)
9. Ensure that the power is OFF before you start connecting up the circuit. (Otherwise you will be touching the live parts in thecircuit)

10. Get your circuit diagram approved by the staff member and connect up the circuit strictly as per the approved circuit diagram.
11. Check power chords for any sign of damage and be certain that the chords use **safety** plugs and do not defeat the **safety** feature of these plugs by using ungrounded plugs.
12. When using connection leads, check for any insulation damage in the leads and avoid such defective leads.
13. Switch on the power to your circuit and equipment only after getting them checked up and approved by the staff member.
14. Do not make any change in the connection without the approval of the staff member.
15. In case you notice any abnormal condition in your circuit (like insulation heating up, resistor heating up etc.), switch off the power to your circuit immediately and inform the staff member.
16. Keep hot soldering iron in the holder when not in use.
17. After completing the experiment show your readings to the staff member and switch off the power to your circuit after getting approval from the staff member.
18. Some students have been found to damage meters by mishandling in the following ways:
  - i. Keeping unnecessary material like books, lab records, unused meters etc. causing meters to fall down the table.
  - ii. Putting pressure on the meter (specially glass) while making connections or while talking or listening to somebody.

## NOTES

1. The students will be split in batches. After splitting the batches they should do the experiments only with their batch members till the end of semester unless there is a change made by the staff. They should not mingle with other batch mates unless the staff asks them to do so.
2. Manual is only for the reference purpose. The experiments reading should be noted down only in the observation notebook.

3. The students should maintain an observation note book separately which should be brought to every lab class without fail. No students will be allowed to enter the lab class without observation note book and record notebook.
4. The experiments will be splitted up as Cycle-I & Cycle-II. The students must write well in advance all the experiments of that particular cycle of which they are going to begin.
5. The students must come to lab class by preparing for the particular experiment they do for that day and the experiment should well be written in the observation before they come to the lab class.
6. Each experiment will be awarded an assessment marks. Total of 10 marks will be assigned as assessment mark for each experiment out of which 5 marks will be awarded based on the number of days of which the students gets their experiment corrected in the observation notebook. The mark will be awarded as follows:

Getting signed on the day of experiment - 5 Marks  
1 day from the day of experiment - 5 Marks  
2 days from the day of experiment - 4 Marks  
3 days from the day of experiment - 3 Marks  
4 days from the day of experiment - 2 Marks  
5 days from the day of experiment - 1 Mark

These days are exclusive of Sundays and public holidays.

After 5 days no observation will be signed by the staff member.

The remaining 5 marks will be awarded based on how the student he/she answers the Viva- Voice question which will be asked at the beginning and end of each experiment.

7. The students can get sign in the observation note book only from the in charge staff or from assist staff.
8. If the student does not get the particular experiment signed on the observation, they should not write that particular experiment in their record notebook and they will also not be given any assessment marks for that particular experiment.
9. The circuit diagrams should be drawn only using HB pencil, Scale, Pro circle, etc. No rough diagrams are entertained.
10. At the end of each experiment completed on that particular day Viva Voice questions will be asked by the staff members. The Viva voice questions can be from any part of that particular subject.
11. No student should take leave on the day of Lab class unless for the case of emergency. In case they absent themselves, the particular student he/she will not be allowed to repeat the experiment for which they absent.
12. The Student who absent themselves for the lab class will be allowed to enter the lab only after getting their leave form signed from the Class In charge and the HOD of their respective department.
13. No repetition classes for any student will be allowed unless the staff asks them to do so.

## GUIDELINES FOR LABORATORY NOTEBOOK

The laboratory notebook is a record of all work pertaining to the experiment. This record should be sufficiently complete so that you or anyone else of similar technical background can duplicate the experiment and data by simply following your laboratory notebook. Record everything directly into the notebook during the experiment. Do not use scratch paper for recording data. Do not trust your memory to fill in the details at a later time.

Organization in your notebook is important. Descriptive headings should be used to separate and identify the various parts of the experiment. Record data in chronological order. A neat, organized and complete record of an experiment is just as important as the experimental work.

### 1. Heading:

The experiment identification (number) should be at the top of each page. Your name and date should be at the top of the first page of each day's experimental work.

### 2. Object:

A brief but complete statement of what you intend to find out or verify in the experiment should be at the beginning of each experiment.

### 3. Diagram:

A circuit diagram should be drawn and labeled so that the actual experiment circuitry could be easily duplicated at any time in the future. Be especially careful to record all circuit changes made during the experiment.

### 4. Equipment List:

List those items of equipment which have a direct effect on the accuracy of the data. It may be necessary later to locate specific items of equipment for rechecks if discrepancies develop in the results.

### 5. Procedure:

In general, lengthy explanations of procedures are unnecessary. Be brief. Short commentaries along side the corresponding data may be used. Keep in mind the fact that the experiment must be reproducible from the information given in your notebook.

#### 6. Data:

Think carefully about what data is required and prepare suitable datatables. Record instrument readings directly. Do not use calculated results in place of direct data; however, calculated results may be recorded in the same table with the direct data. Data tables should be clearly identified and each data column labeled and headed by the proper units of measure.

#### 7. Calculations:

Not always necessary but equations and sample calculations are often given to illustrate the treatment of the experimental data in obtaining the results.

#### 8. Graphs:

Graphs are used to present large amounts of data in a concise visual form. Data to be presented in graphical form should be plotted in the laboratory so that any questionable data points can be checked while the experiment is still set up. The grid lines in the notebook can be used for most graphs. If special graph paper is required, affix the graph permanently into the notebook. Give all graphs a short descriptive title. Label and scale the axes. Use units of measure. Label each curve if more than one on a graph.

#### 9. Results:

The results should be presented in a form which makes the interpretation easy. Large amounts of numerical results are generally presented in graphical form. Tables are generally used for small amounts of results. Theoretical and experimental results should be on the same graph or arranged in the same table in a way for easy correlation of these results.

#### 10. Conclusion:

This is your interpretation of the results of the experiment as an engineer. Be brief and specific. Give reasons for important discrepancies.

## **TROUBLE SHOOTING HINTS**

1. Be Sure that the power is turned ON
2. Be sure the ground connections are common
3. Be sure the circuit you build is identical to your circuit diagram (Do a node by node check)
4. Be sure that the supply voltages are correct
5. Be sure that the equipment is set up correctly and you are measuring the correct parameters
6. If steps 1 through 5 are correct then you probably have used a component with the wrong value or one that doesn't work. It is also possible that the equipment does not work (although this is not probable) or the protoboard you are using may have some unwanted paths between nodes. To find your problem you must trace through the voltages in your circuit node by node and compare the signal you expect to have. Then if they are different use your engineering judgment to decide what is causing the difference or ask your lab assistant

SRM VEC EPL-ELECTRONICS LAB MANUAL

## List of Experiments

### Group B (Electrical & Electronics)

#### **ELECTRONICSENGINEERINGPRACTICE**

**13**

1. Study of Electronic components and equipments – Resistor, colour coding measurement of AC signal parameter (peak-peak, rms period, frequency) using CRO and Multimeter.
2. Study of logic gates AND, OR, EX- OR and NOT.
3. Generation of Clock Signal.
4. Soldering practice – Components Devices and Circuits – Using general purpose PCB.
5. Measurement of ripple factor of HWR and FWR

S.No.	Experiments	Page. No	Marks Awarded (10)	Staff Signature
1.	Study of Electronic components and equipments – Resistor, colour coding measurement of AC signal parameter (peak-peak, rms period, frequency) using CRO and Multimeter.			
2.	Study of logic gates AND, OR, EX -OR and NOT			
3.	Generation of Clock Signal.			
4.	Soldering practice – Components Devices and Circuits – Using general purpose PCB.			
5.	Measurement of ripple factor of HWR and FWR			



ExpNo: 1A

Date :

## STUDY OF ELECTRONIC COMPONENTS AND EQUIPMENTS

### AIM

To study about the Electronic Components and Equipments such as Active and different types of Passive components are Resistors, Capacitors and Inductors.

### TYPES OF ELECTRONIC COMPONENTS

#### ACTIVE COMPONENT

##### Definition:

Active components are those that require electrical power to operate. This could include the power supply, fans, storage device, transistors, diodes and other integrated circuits.

### TRANSISTORS

A transistor is a semiconductor device used to amplify and switch electronic signals and electrical power. It is composed of semiconductor material with at least three terminals for connection to an external circuit. A voltage or current applied to one pair of the transistor's terminals changes the current flowing through another pair of terminals.

### TYPES OF TRANSISTORS

1. Bipolar Junction Transistor
2. Field Effect Transistor



### DIODES

An electronic device with two active terminals, an anode and a cathode, through which current passes more easily in one direction (from anode to cathode) than in the reverse

direction. Diodes have many uses, including conversion of AC power to DC power, and the decoding of audio-frequency signals from radio signals.

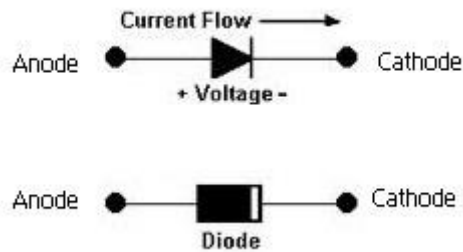

## TYPES OF DIODES

1. PN Junction Diode
2. PIN Diode
3. Zener Diode
4. Tunnel Diode

## PASSIVE COMPONENTS

### Definition:

A passive component is a module that does not require energy to operate, except for the available Alternating Current (AC) circuit that it is connected to. A passive module is not capable of power gain and is not a source of energy. A typical passive component would be a chassis, inductor, resistor, transformer, or capacitor.

### Types of active and passive components

Sl.No	Active Components	Passive Components
1	Transistors	Resistor
2	Op-Amps	Capacitor
3	Diodes	Inductor

## **PASSIVE COMPONENTS**

### **RESISTORS**

Resistors are the most common components in electronic circuits. Its main function is to reduce the high current to the desired value and also to provide desired voltage in the circuit. The resistors are manufactured to have a specific value in ohm. The physical size of resistor determines how much power can be dissipated in the form of heat. However there is co-relation between resistor physical sizes and its resistance value. They are manufactured in variety of standard values and powersettings.

There are two types of resistors:

- Fixedresistor
- Variable resistor

Fixed resistor has a resistance value that does not change where as a variable resistor having variable resistance range with 4 lines or color code. They indicate the resistance value in ohms out on a larger resistor; the resistance value is printed on the body of the resistor.

The important feature of resistor is that its effect is same for both AC and DC circuits.

### **TYPES OF RESISTORS**

- Wire wandresistors
- Carbon Compositionresistors
- Filmresistors
- Surface mountresistors
- Fusible resistors

### **CAPACITOR**

A capacitor is a passive two terminal component which stores electric charge. This component consists of two conductors which are separated by a dielectric medium. The potential difference when applied across the conductors polarizes the dipole ions to store the charge in the dielectric medium. The unit of capacitance is Farad and it is denoted as F. The circuit symbol of a capacitor is shownbelow:

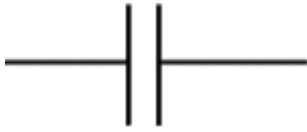

Symbolic representation



Disc capacitor



Polarity representation

Consider the capacitor below:



The capacitor on the left is of a ceramic disc type capacitor that has the code 473J printed onto its body. Then the 4 = 1<sup>st</sup> digit, the 7 = 2<sup>nd</sup> digit, the 3 is the multiplier in pico-Farads, pF and the letter J is the tolerance and this translates to:

$$47\text{pF} * 1,000 \text{ (3 zero's)} = 47,000 \text{ pF , } 47\text{nF} \text{ or } 0.047 \text{ uF}$$

the J indicates a tolerance of +/- 5%

The capacitance or the potential storage by the capacitor is measured in Farads which is symbolized as 'F'. One Farad is the capacitance when one coulomb of electric charge is stored in the conductor on the application of one volt potential difference.

The charge stored in a capacitor is given by

$$Q = CV$$

Where Q - charge stored by the capacitor

C - Capacitance value of the capacitor

V - Voltage applied across the capacitor

## TYPES OF CAPACITORS

- Ceramic capacitor

- Electrolytic capacitor
- Tantalum capacitor
- Silver Mica Capacitor
- Polystyrene Film Capacitor
- Polyester Film Capacitor
- Metalized Polyester Film Capacitor
- Polycarbonate capacitor
- Polypropylene Capacitor
- Glass capacitors

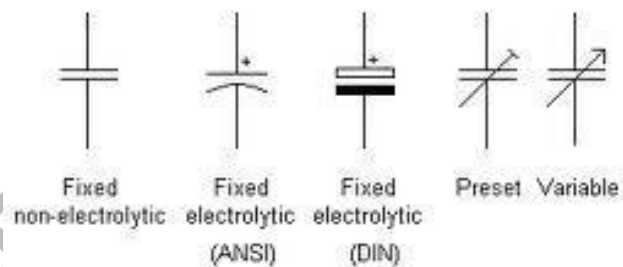
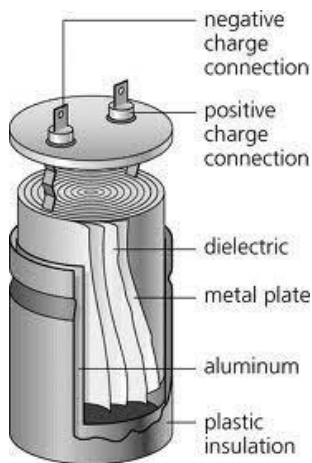

Design of capacitor

Symbolic representations

## INDUCTOR

An inductor (also [choke](#), coil or reactor) is a [passive two-terminal electrical component](#) that stores [energy](#) in its [magnetic field](#). For comparison, a [capacitor](#) stores energy in an [electric field](#), and a [resistor](#) does not store energy but rather dissipates energy as heat. The inductance is Henry and it is denoted as H.

Any conductor has inductance. An inductor is typically made of a wire or other conductor wound into a [coil](#), to increase the magnetic field. When the current flowing through an inductor changes, creating a time-varying magnetic field inside the coil, a voltage is induced according to [Faraday's law of electromagnetic induction](#), which by [Lenz's law](#) opposes the

change in current that created it. Inductors are one of the basic components used in electronics where current and voltage change with time, due to the ability of inductors to delay and reshape alternating currents.

### TYPES OF INDUCTORS

- Air core inductor
- 
- Radio frequency inductor
- Ferromagnetic core inductor
- Laminated core inductor
- Ferrite-core inductor
- Toroidal core inductor
- Variable inductor

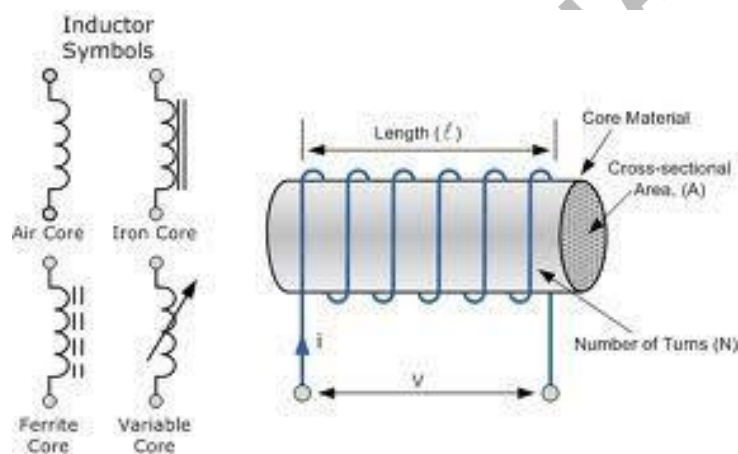

Design and Symbolic representation

### Result:

Thus the above study experiment electronic components and equipments was studied clearly.

Exp No: 1B

Date : **STUDY OF RESISTOR COLOURCODING**

**Aim:**

To find the value of given resistors using colour coding chart.

**Apparatus Required:**

1. Resistors-various ranges

**Theory:**

**Resistors:**

Resistors have three principal ratings: resistance in ohms, tolerance in percent, and power dissipation in watts. Most of the resistors we have in the lab can dissipate ¼ watt and have tolerances of +or - 5 %.Resistance values are coded on the resistors with color bands. The first two bands give two significant digits of the value, the third band is a multiplier expressed as a power of 10, and the fourth band is the tolerance. The table below shows the color code. For example, red-red orange-gold is 22 KΩ + or - 5 %. Sometimes ¼ watt is not enough for a circuit application and then a physically larger resistor isrequired.

**PROCEDURE:**

1. Find the nominal value and the tolerance of each resistance using the colorcodes
2. Calculate the resistor values and using the digital Multimeter as an ohmmeter, we can cross check and record the resistance ofeach.

**Tabular**

**Column:Resistor Values:**

<b>Resistor</b>	<b>R1</b>	<b>R2</b>	<b>R3</b>
Nominal value / Tolerance			

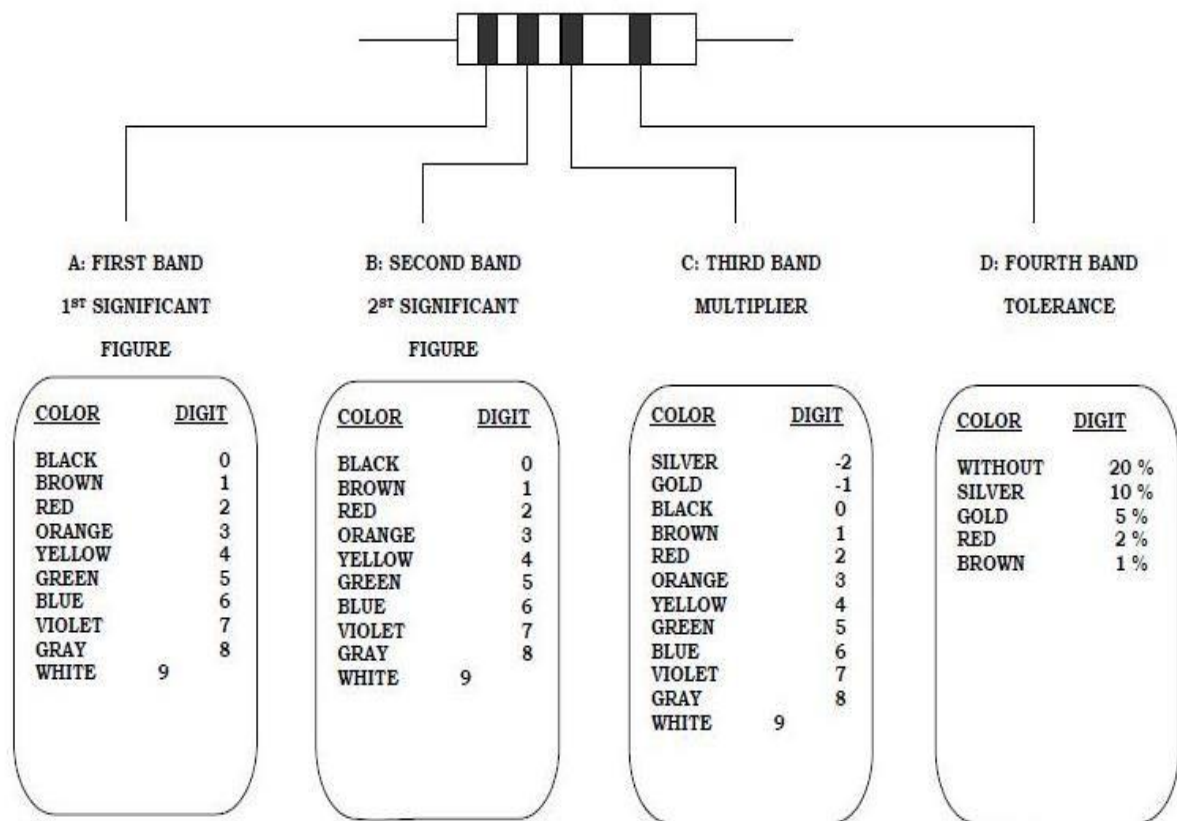

**EXAMPLES**

YELLOW	VIOLET	BROWN	SILVER		BROWN	RED	ORANGE	GOLD	
4	7	0	10 %	=470, 10%	1	2	000	5 %	=12K $\Omega$ , 5%

35

**Result:**

Thus the value of the resistors is obtained by using the colour coding technique.

**VIVA QUESTIONS:**

1. What is a resistor?
2. What is the function of a resistor?
3. How will you find out the resistor value?
4. What is tolerance?



ExpNo: 1C

Date :

**MEASUREMENT OF AC SIGNAL PARAMETER (PEAK-PEAK, RMS, TIME PERIOD AND FREQUENCY) USING CRO**

**Aim:**

To study the electronic components and equipments including the resistor and color coding and to measure the various AC signal parameters (Peak-peak, RMS, Time Period and frequency) using CRO

**Apparatus Required:**

1. CRO
2. Function generator

**Formula used:**

1. Peak to peak voltage  $V_{(p-p)} = \text{No. of divisions} \times \text{Volts/Divisions}$
2. Maximum Voltage  $V_m = V_{(p-p)} / 2 \text{ (V)}$
3. Root Mean Square Voltage  $V_{RMS} = V_m / \sqrt{2} \text{ (V)}$
4. Time period (T) = No. of divisions  $\times$  Time/Divisions (Sec)
5. Frequency (f) = 1/T (Hz)

**AC Sine Waveform**

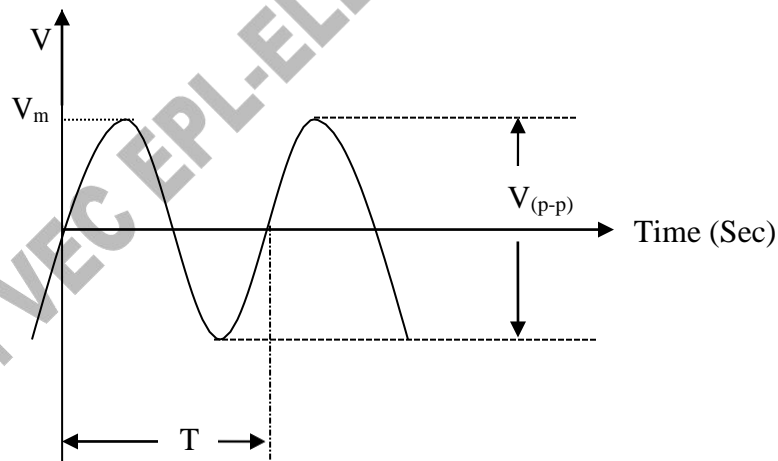

**Tabular Column:**

**Peak to peak Voltage measurement**

No of Divisions	Volts/ Divisions	Peak to Peak voltage $V_{(p-p)}$ (Volts)	RMS voltage $V_{RMS}$ (Volts)

**Time period measurement**

No of Divisions	Time/ Divisions	Time period (s)	Frequency (HZ)

**Theory:**

A sinusoidal signal is a general sine function. An electrical signal is a voltage or current which conveys information, usually it means a voltage. The term can be used for any voltage or current in a circuit. The voltage-time graph above shows the various properties of an electrical signal. In addition to the properties labelled on the graph, there is frequency which is the number of cycles per second. The diagram shows a sine wave but these properties apply to any signal with a constant shape.

- Amplitude is the maximum voltage reached by the signal. It is measured in volts, V.
- Peak voltage is another name for amplitude.
- Peak-peak voltage is twice the peak voltage (amplitude). When reading an Oscilloscope trace it is usual to measure peak-peak voltage. The peak-to-peak value of the voltage is simply the difference between the largest voltage (usually positive) and the smallest voltage (usually negative).

- Time period is the time taken for the signal to complete one cycle, it is measured in seconds (s), but time periods tend to be short so milliseconds (ms) and micro seconds ( $\mu$ s) are often used.  $1\text{ms} = 0.001\text{s}$  and  $1\mu\text{s} = 0.000001\text{s}$ .
- Frequency is the number of cycles per second it is measured in hertz (Hz), but frequencies tend to be high so kilohertz (kHz) and megahertz (MHz) are often used.  $1\text{kHz} = 1000\text{Hz}$  and  $1\text{MHz} = 1000000\text{Hz}$ .
- RMS value is the effective value of a varying voltage or current. It is the equivalent steady DC (constant) value which gives the same effect

**Procedure:**

1. AC signal is given as an input to CRO.
2. The CRO display is noted.
3. From the display the various parameters like peak-peak voltage, maximum voltage and time period are noted.
4. By using the formulas, the RMS value and frequency are calculated.

**Result:**

Thus the various AC signal parameters (Peak-peak, RMS, Period and frequency) were measured using CRO.

**VIVA QUESTIONS:**

1. What is meant by AC supply?
2. What is peak to peak voltage?
3. What is rms voltage?
4. What is maximum voltage?
5. What is Frequency?
6. How is the time period measured?

**Exp No: 2**

**Date : STUDY OF LOGICGATES**

**AIM**

The purpose of this experiment is to get familiar with the elementary Logic gates and to know the use of them for implementing logic circuits.

**COMPONENTS REQUIRED**

S. No.	COMPONENTS	SPECIFICATION	QTY
1.	AND GATE	IC 7408	1
2.	OR GATE	IC 7432	1
3.	NOT GATE	IC 7404	1
5.	IC TRAINER KIT	-	1
6.	PATCH CORD	-	14

**THEORY**

Digital electronics is found in everything from computers to CD players and watches. It is based on the binary number system. Instead of voltages which vary continuously, as in analog electronics, digital circuits involve voltages which take one of only two possible values. In our case these are 0 and 5 volts (TTL logic), but they are often referred to as LOW and HIGH, or FALSE and TRUE, or as the binary digits 0 and 1. The basic building blocks of digital electronics are logic gates which perform simple binary logic functions (AND, OR, NOT, etc.). From these devices, one can construct more complex circuits to do arithmetic, act as memory elements, and so on. In this lab, you will look at a few basic devices to see what they can do. Logic gates and other digital components come in the form of integrated circuits (ICs) which consist of small semiconductor chips packaged in a ceramic or plastic case with many pins. The ICs are labeled by numbers like 74LSxx, where xx is a number identifying the type of device.

## PIN DIAGRAM of IC's

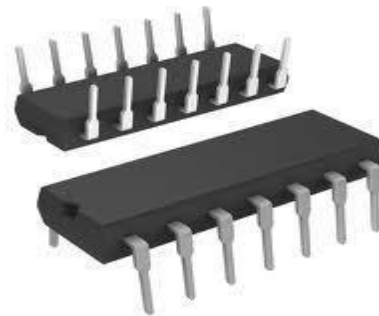
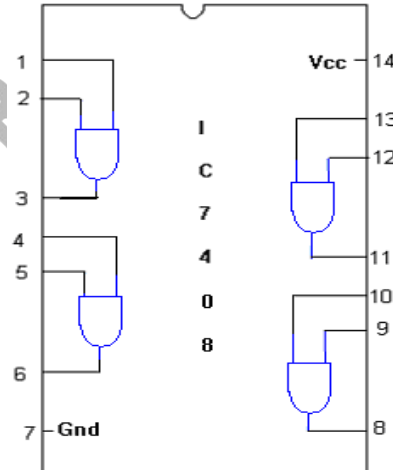
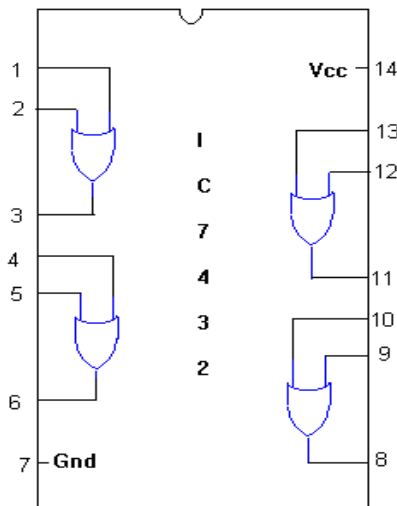
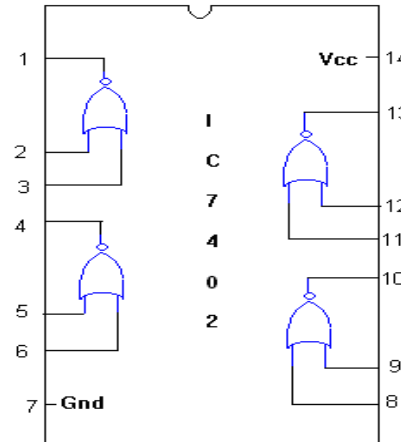
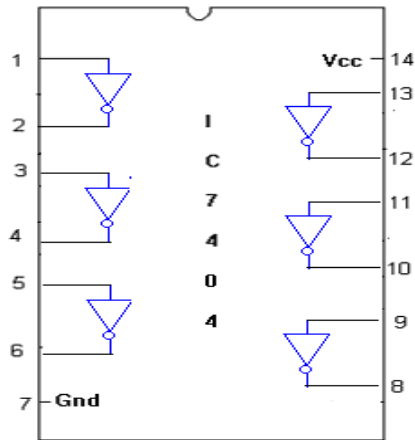

Picture Representation of an IC

## LOGIC GATES

### NOT GATE (IC 7404)

In digital logic, an inverter or NOT gate is a logic gate which implements logical negation. The 7404 chip contains six inverters. An inverter simply converts binary 1 to 0 and vice versa.

#### NOT gate (7404)

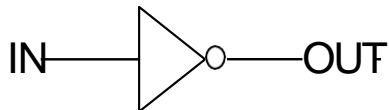

#### TRUTH TABLE

IN	OUT
1	
0	

### AND GATE (IC 7408)

The AND gate is a digital logic gate that implements logical conjunction- it behaves according to the truth table to the right. A HIGH output (1) results only if both the inputs to the AND gate are HIGH (1). If neither or only one input to the AND gate is HIGH, a LOW output results. In another sense, the function of AND effectively finds the minimum between two binary digits, just as the OR function finds the maximum.

#### AND gate (7408)

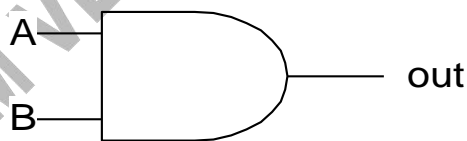

#### TRUTH TABLE

A	B	OUT
0	0	
0	1	
1	0	
1	1	

### OR GATE (IC 7432)

The OR gate is a digital logic gate that implements logical disjunction - it behaves according to the truth table to the right. A HIGH output (1) results if one or both the inputs to the gate are HIGH (1). If neither input is HIGH, a LOW output (0) results. In another sense, the function of OR effectively finds the maximum between two binary digits, just as the complementary AND function finds the minimum.

## OR GATE (7432)

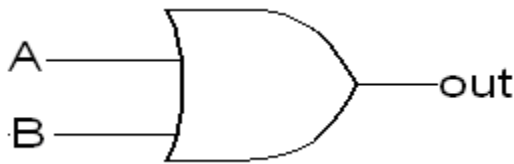

### TRUTH TABLE

A	B	OUT
0	0	
0	1	
1	0	
1	1	

## Exclusive OR Gate – EXOR Gate (IC 7486)

The **EXOR gate** is used extensively in digital data processing circuits and is known as **Exclusive-OR-gate**. The EXOR gate has a high output only when an odd number of inputs are high. For the two input EXOR gates, the output will be high when the set of input is either 01 or 10. The XOR gate is used in the adder, subtractor and controlled inverter circuit. It is also used in the computers for implementing the binary addition.



### TRUTH TABLE

A	B	OUT
0	0	
0	1	
1	0	
1	1	

### Result:

Thus the basic logic gates were studied and its truth table are tabulated.

### VIVA QUESTIONS

1. What are the universal gates?
2. Draw the truth table of AND gate.
3. Draw the truth table of NOT gate.
4. Draw the truth table of OR gate.
5. How many gates will be there in a IC 7404 chip?
6. What gate does the IC 7408 consist of?
7. What are the 7<sup>th</sup> and 14<sup>th</sup> pin in all the gates?

ExpNo: 3

Date :

## GENERATION OF CLOCK SIGNAL

### Aim:

To generate a clock signal in AstableMultivibrator using 555 timer.

### Apparatus Required:

S.No	Equipment Required	Quantity	Type/Range
1	555 Timer IC	1	555 Timer
2	Resistance	1	6.8K $\Omega$ ,3.3K $\Omega$
3	Capacitors	1	0.01 $\mu$ F,0.101 $\mu$ F
4	CRO	1	0-30MHz
5	RPS (0-30)V	1	0-30V
6	Bread board	1	
7	Connecting wires		

### Theory:

Timing resistor is split into  $R_a$  and  $R_b$ . Pin 7 is connected to the junction of  $R_a$  and  $R_b$  along with power supply  $V_{cc}$ . External timing capacitor  $C$  charges towards  $V_{cc}$  with time constant  $(R_a + R_b)C$ . During this time, the output at the pin 3 is high.

When the capacitor voltage equals to  $2/3 V_{cc}$ , the upper comparator trigger the control flip-flop.

### Formula used:

1.  $T_{on} = 0.69 ((R_a + R_b)C)$
2.  $T_{off} = 0.69R_bC$
3.  $T = T_{on} + T_{off}$



PIN DIAGRAM

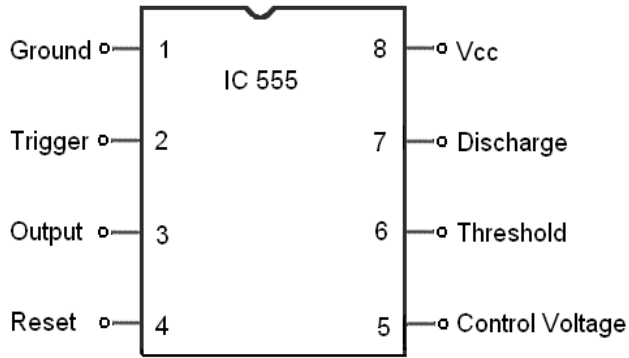

Circuit Diagram

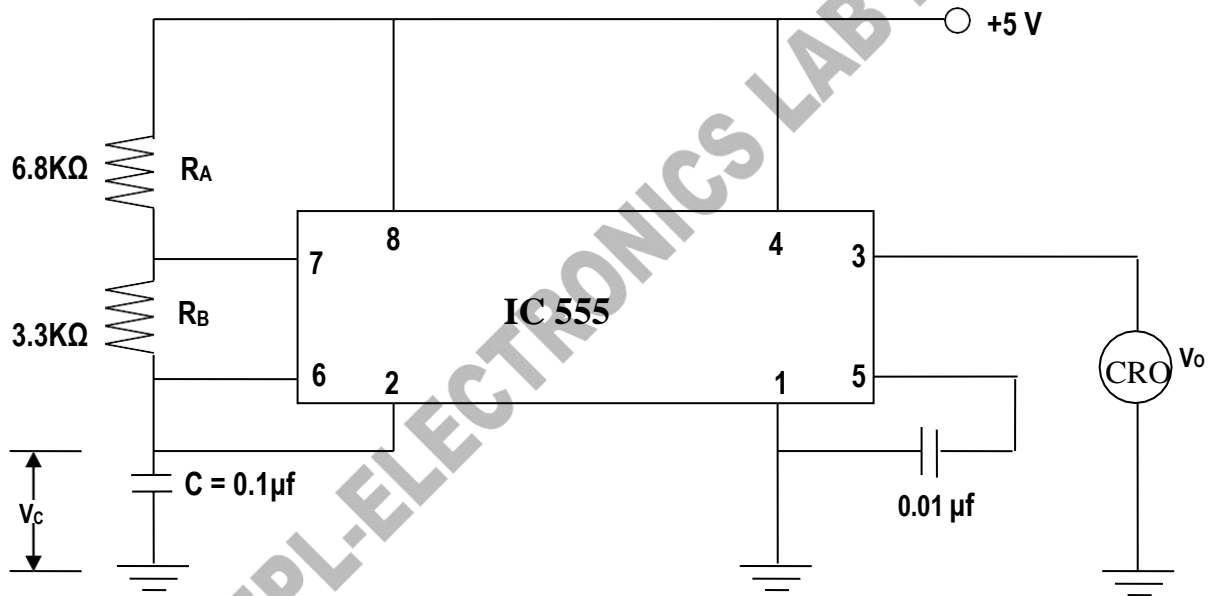

Tabular Column

Sl.No	Resistance values KΩ	ON time T <sub>on</sub> (Sec)	OFF time T <sub>off</sub> (Sec)	Total time T <sub>on</sub> + T <sub>off</sub> (Sec)	Frequency F= 1/T (HZ)

### WAVEFORM

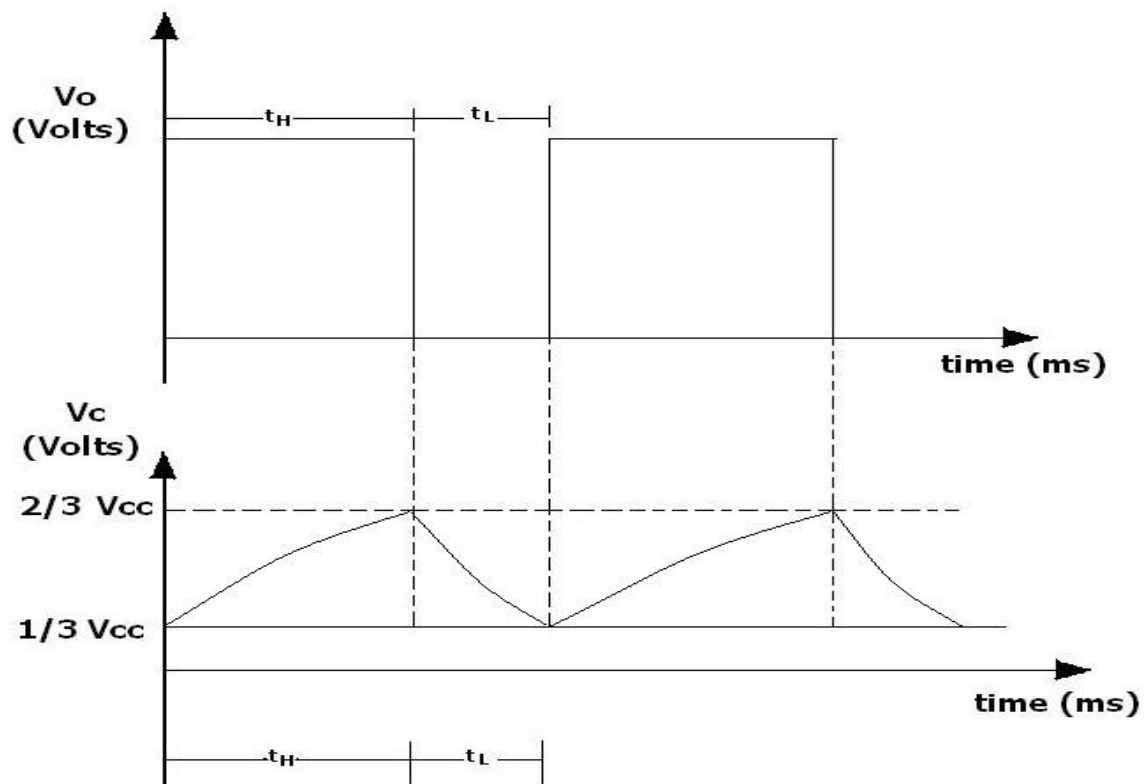

#### **Procedure:**

#### **CAPACITOR WAVEFORM**

1. Connections are made as per the circuit diagram.
2. +5 Volts is given to the  $V_{cc}$  terminal.
3.  $t_{on}$ ,  $t_{off}$  values are calculated from the given formula.
4. The graph is drawn.

#### **Result:**

Thus a clock signal was generated using 555 timer IC for different values of resistances.

#### **Viva Questions**

1. What is a clock signal?
2. What are the applications of Clock signal?
3. What is the purpose of CRO?
4. Can we generate clock signal without using 555 timer?
5. What is the use of triggering signal, Threshold and control voltage?

ExpNo: 4

Date :

**SOLDERING PRACTICE COMPONENTS DEVICES AND**  
**CIRCUITS USING GENERAL PURPOSE PCB**

**Aim:**

To practice soldering and desoldering for the electronic circuit by assembling and disassembling the resistor  $R_1$  and  $R_2$  and capacitor  $C_1$  in the given Printed Circuit Board (PCB).

**COMPONENT REQUIRED**

S.No	Component	Range	Quantity
1	PCB board for given circuit	10w(or)35w	1
2	Soldering iron	60/40 grade	1
3	Solder		1
4	Flux		1
5	Electrician's Knife		1
6	Nose plier		1
7	Resistors	10k $\Omega$	4
8	Capacitor	0.01 $\mu$ F	2

**Given circuit**

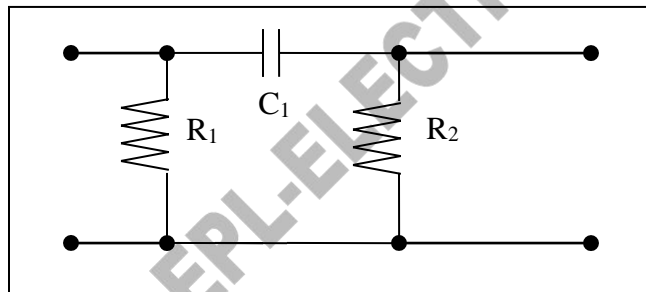

**Drawing**

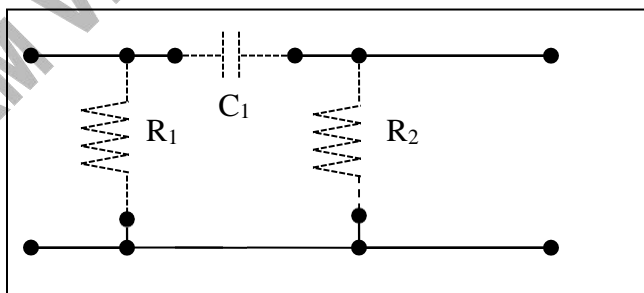

Back side of the PCB board

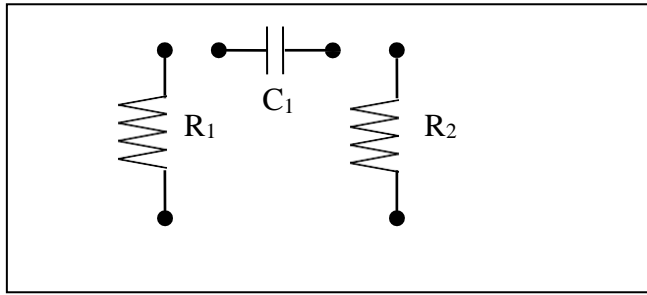

Front side of the PCB board

## Circuit 2

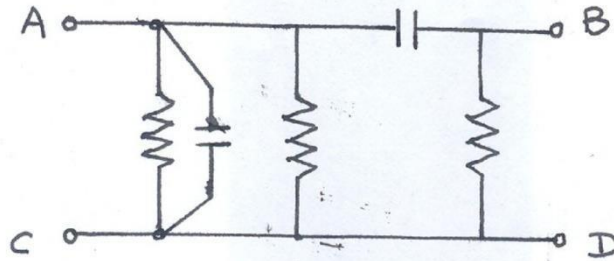

### Procedure:

#### Soldering

1. The given electronic circuit is studied.
2. The PCB board is cleaned.
3. The tip of the soldering iron is cleaned before heating and also the resistors and capacitor which is to be soldered is cleaned.
4. The soldering iron is heated and the solder is applied to the tip of it.
5. The resistor (R) leads are bent to fit the holes on the board and they are inserted in the holes of the board as per the circuit diagram.
6. The hot tip is applied to the joints and the solder is applied.
7. The soldering tip is removed and the resistor is held tightly till the solder is cooled and set.
8. The excess component lead is trimmed with sidecutters.
9. The above steps are repeated to fix the other resistor and capacitor in the circuit.

## De-Soldering

1. The tip of the soldering iron is placed on the resistor- board joint until the solder is melt.
2. When the solder is melted the resistor is removed with a tweezers and the molten solder is removed.
3. The above steps are repeated to remove the other resistor and capacitor.
4. The resistors and capacitors are cleaned.

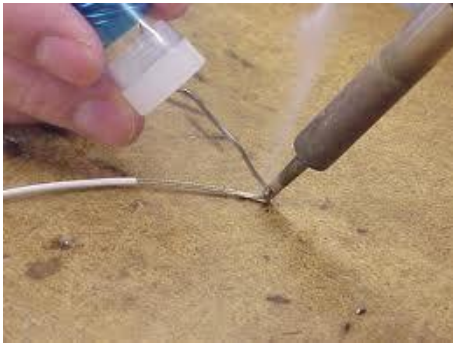

Soldering way

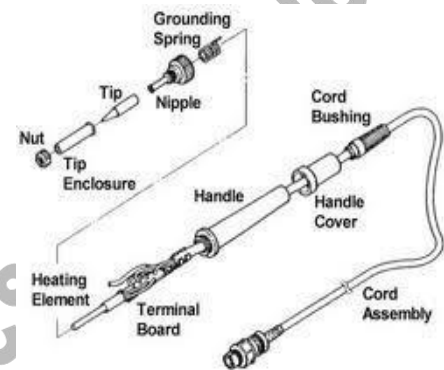

Solder gun

## **Result:**

Thus the soldering and de-soldering practice is done for the given electronic circuit.

## VIVA QUESTIONS

1. What is a Resistor?
2. What is a capacitor?
3. What is Soldering and De-Soldering?
4. What is a PCB? State the use of PCB?
5. What are the uses of soldering and de-soldering?

ExpNo: 5A

Date :

**MEASUREMENT OF RIPPLE FACTOR FOR HALF WAVE  
RECTIFIERS**

**AIM:**

To study the ripple factor of a half wave rectifier.

**EQUIPMENTS REQUIRED:**

SL.NO.	NAME OF THE EQUIPMENT	RANGE	QUANTITY
1.	Transformer	12v-0v-12v	1
2.	Capacitor	0.1 $\mu$ F	2
3.	Resistor	470 $\Omega$	1
4.	PN junction diode	IN 4007	2
5.	Bread Board	-	1
6.	CRO	-	1

**FORMULAE USED:**

$$\text{RippleFactor}, \gamma = \sqrt{(V_{\text{rms}} / V_{\text{dc}})^2 - 1}$$

Where,  $V_{\text{rms}}$  = Therms value of the a.c component of the output voltage

$V_{\text{dc}}$  = The average or d.c value of the output voltage.

**HALF WAVE RECTIFIER:**

$$V_{\text{dc}} = V_{\text{m}}/2\pi$$

$$V_{\text{rms}} = V_{\text{m}}/2$$

**Theory:**

A rectifier is defined as a electronic device used for converting AC voltage into unidirectional voltage. A rectifier utilizes unidirectional conduction devices like Vacuum diode or PN junction diode.

**Half wave rectifier:**

It converts an ac voltage into a pulsating DC voltage using only one half of the applied ac voltage. The rectifying diode conducts during one half of the ac cycle. During

positive half cycle of the input signal the anode of diode becomes positive with respect to cathode and hence the diode conducts. For an ideal diode the forward voltage drop is zero so the whole input voltage appears across the load. During negative half of the input signal the anode of the diode becomes negative with respect to cathode and hence the diode does not conduct. For an ideal diode the impedance offered by the diode is unity so the whole input voltage drop across diode. Hence voltage drop across  $R_L$  is zero.

### CIRCUIT DIAGRAM

#### Half Wave Rectifier

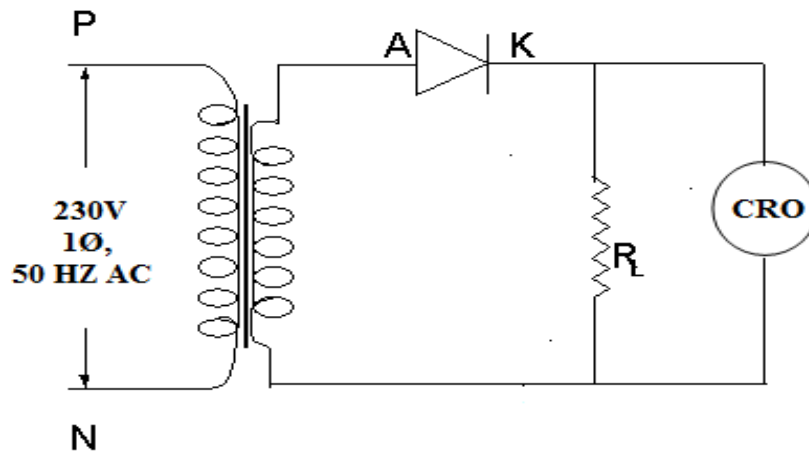

### MODEL GRAPH:

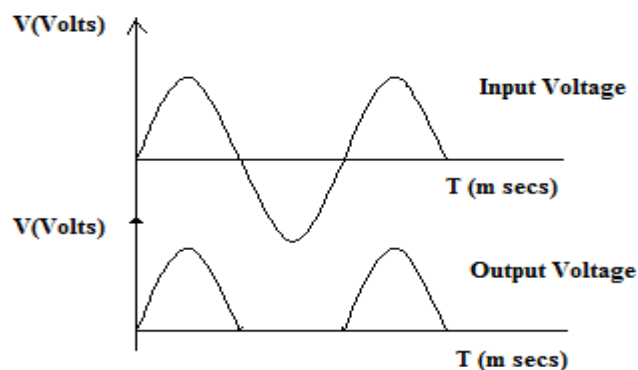

**TABULATION:**

<b>TYPE OF RECTIFIER</b>	<b>V<sub>m</sub></b>	<b>Time Period</b>	<b>Ripple factor</b>
Half Wave Rectifier			

**PROCEDURE:**

1. Connect the circuit as per the circuit diagram.
2. Connect the CRO across the load.
3. From the waveform in the CRO screen, note down the amplitude and frequency along with multiplication factor.
4. Calculate the ripple factor.

**RESULT:**

Thus the input & output waveforms are drawn for half wave rectifiers and ripple factor calculated.

**VIVA QUESTIONS:**

1. Define Rectifier?
2. What is Half-Wave Rectifier?
3. Define Ripple Factor?
4. What type of output we get from HW Rectifier?
5. What is the value of Ripple factor for HW Rectifier?
6. What is the formulae for  $V_{rms}$  for HW Rectifier?
7. What is the formulae for  $V_{dc}$  for HW Rectifier?



ExpNo: 5B

Date :

## **MEASUREMENT OF RIPPLE FACTOR FOR FULL WAVE RECTIFIERS**

### **AIM:**

To study the ripple factor and regulation characteristics of a full wave rectifier.

### **EQUIPMENTS REQUIRED:**

SL.NO.	NAME OF THE EQUIPMENT	RANGE	QUANTITY
1.	Transformer	12v-0v-12v	1
2.	Capacitor	0.1 $\mu$ F	2
3.	Resistor	470 $\Omega$	1
4.	PN junction diode	IN 4007	2
5.	Bread Board	-	1
6.	CRO	-	1

### **FORMULA USED:**

$$\text{RippleFactor}, \gamma = \sqrt{(V_{\text{rms}} / V_{\text{dc}})^2 - 1}$$

Where,  $V_{\text{rms}}$  = Therms value of the a.c component of the output voltage

$V_{\text{dc}}$  = The average or d.c value of the output voltage.

### **FULL WAVE RECTIFIER:**

$$V_{\text{dc}} = 2 V_{\text{m}} / \pi$$

$$V_{\text{rms}} = V_{\text{m}} / \sqrt{2}$$

### **Theory:**

A rectifier is defined as a electronic device used for converting AC voltage into unidirectional voltage. A rectifier utilizes unidirectional conduction devices like Vacuum diode or PN junction diode.

### **Full wave rectifier:**

It converts an AC voltage into a pulsating DC voltage using both half cycles of the applied AC voltage. It uses two diodes of which one conducts during positive half cycle while the other conducts during negative half cycle. During positive half cycle of the input signal anode of the diode D1 becomes positive with respect to cathode and at the same time anode of the diode becomes negative. Hence D1 conducts and D2 will not conduct during positive half cycle. During negative half of the input anode of the diode D1 becomes negative and anode of diode D2 becomes positive. Hence D1 does not conduct and D2 will conduct. The load current flows through D2 and voltage drop across  $R_L$  will be equal to the input voltage.

### **PROCEDURE:**

1. Connect the circuit as per the circuit diagram.
2. Connect the CRO across the load.
3. From the waveform in the CRO screen, note down the amplitude and frequency along with multiplication factor.
4. Calculate the ripple factor.

### **CIRCUIT DIAGRAM**

### **FULL WAVE RECTIFIER**

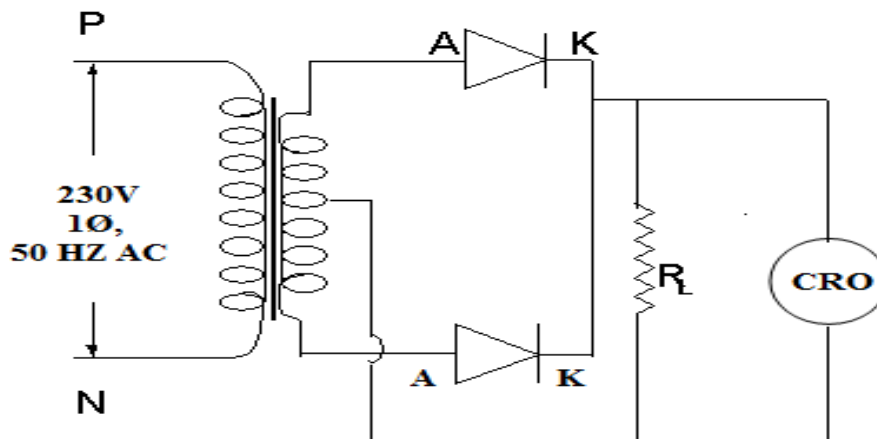

## **MODELGRAPH**

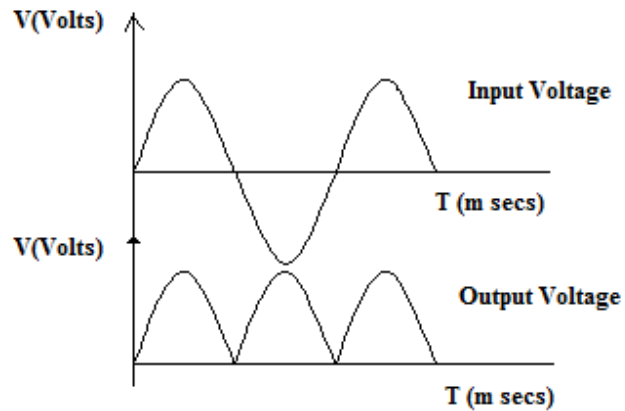

## **TABULATION:**

<b>TYPE OF RECTIFIER</b>	<b>V<sub>m</sub></b>	<b>Time Period</b>	<b>Ripple factor</b>
Full Wave Rectifier			

## **RESULT:**

Thus the input & output waveforms are drawn for full wave rectifiers and ripple factor calculated

## **VIVA QUESTIONS:**

1. Define Full waverectifier?
2. What is the formulae for V<sub>dc</sub>for FWRectifier?
3. What is the formulae for V<sub>rms</sub>for FWRectifier
4. What type of output we get from FWRectifier?
5. What is the value of Ripple factor for FWRectifier?

**Ex.No.1      CHARACTERISTICS OF SEMICONDUCTOR DIODE**

**AIM:**

To study the PN junction diode characteristics under Forward & Reverse bias conditions.

**APPARATUS REQUIRED:**

S.No.	Name	Range	Type	Qty
1	R.P.S			
2	Ammeter			
3	Voltmeter			

**COMPONENTS REQUIRED:**

S.No.	Name	Range	Type	Qty
1	Diode			
2	Resistor			
3	Bread Board			
4	Wires			

**THEORY:**

A PN junction diode is a two terminal junction device. It conducts only in one direction (only on forward biasing).

**FORWARD BIAS:**

On forward biasing, initially no current flows due to barrier potential. As the applied potential exceeds the barrier potential the charge carriers gain sufficient energy to cross the potential barrier and hence enter the other region. The holes, which are majority carriers in the P-region, become minority carriers on entering the N-regions, and electrons, which are the majority carriers in the N-region, become minority carriers on entering the P-region. This injection of Minority carriers results in the current flow, opposite to the direction of electron movement.

### **REVERSE BIAS:**

On reverse biasing, the majority charge carriers are attracted towards the terminals due to the applied potential resulting in the widening of the depletion region. Since the charge carriers are pushed towards the terminals no current flows in the device due to majority charge carriers. There will be some current in the device due to the thermally generated minority carriers. The generation of such carriers is independent of the applied potential and hence the current is constant for all increasing reverse potential. This current is referred to as Reverse Saturation Current ( $I_0$ ) and it increases with temperature. When the applied reverse voltage is increased beyond the certain limit, it results in breakdown. During breakdown, the diode current increases tremendously.

### **PROCEDURE:**

#### **FORWARD BIAS:**

1. Connect the circuit as per the diagram.
2. Vary the applied voltage  $V$  in steps of  $0.1V$ .
3. Note down the corresponding Ammeter readings  $I$ .
4. Plot a graph between  $V$  &  $I$

### **OBSERVATIONS**

1. Find the d.c (static) resistance  $=V/I$ .
2. Find the a.c (dynamic) resistance  $r = \delta V / \delta I$  ( $r = \Delta V / \Delta I$ ) =  $\frac{V_2 - V_1}{I_2 - I_1}$ .
3. Find the forward voltage drop = [Hint: it is equal to  $0.7$  for Si and  $0.3$  for Ge]

### **REVERSE BIAS:**

1. Connect the circuit as per the diagram.
2. Vary the applied voltage  $V$  in steps of  $1.0V$ .
3. Note down the corresponding Ammeter readings  $I$ .
4. Plot a graph between  $V$  &  $I$
5. Find the dynamic resistance  $r = \delta V / \delta I$ .

## FORMULA FOR REVERSE SATURATION CURRENT ( $I_0$ ):

$$I_0 = \frac{\partial I}{\partial V} [\exp(\frac{\partial V}{\eta V_T})]^{-1}$$

Where  $V_T$  is the voltage equivalent of Temperature =  $kT/q$

-k is Boltzmann's constant, q is the charge of the electron and T is the temperature in degrees Kelvin.

$\eta = 1$  for Silicon and 2 for Germanium

## CIRCUIT DIAGRAM:

### FORWARD BIAS:

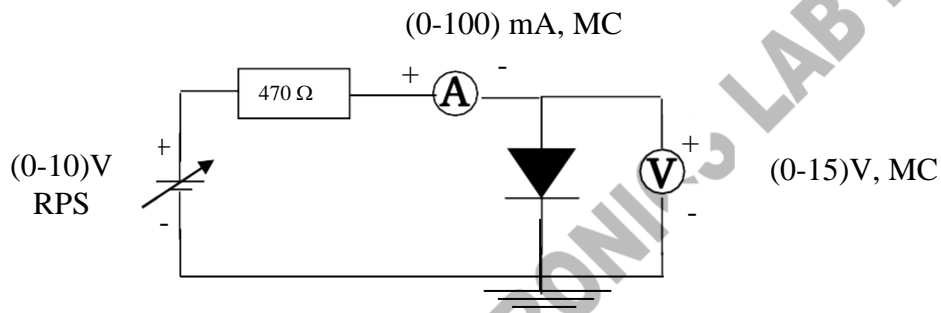

### REVERSE BIAS:

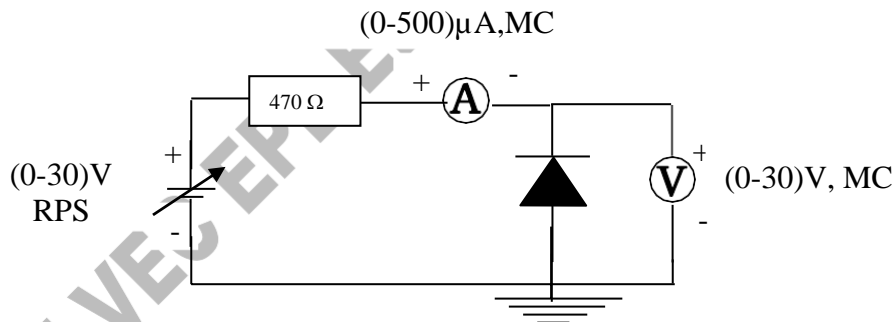

### **Specification for 1N4001: Silicon Diode**

Peak Inverse Voltage: 50V

$I_{dc} = 1A$ .

Maximum forward voltage drop at 1 Amp is 1.1 volts

Maximum reverse current @50 volts is 5μA

## TABULAR COLUMN:

**FORWARD BIAS:**

S.No.	VOLTAGE (In Volts)	CURRENT (In mA)

**REVERSE BIAS:**

S.No.	VOLTAGE (In Volts)	CURRENT (In $\mu\text{A}$ )

**MODEL GRAPH**

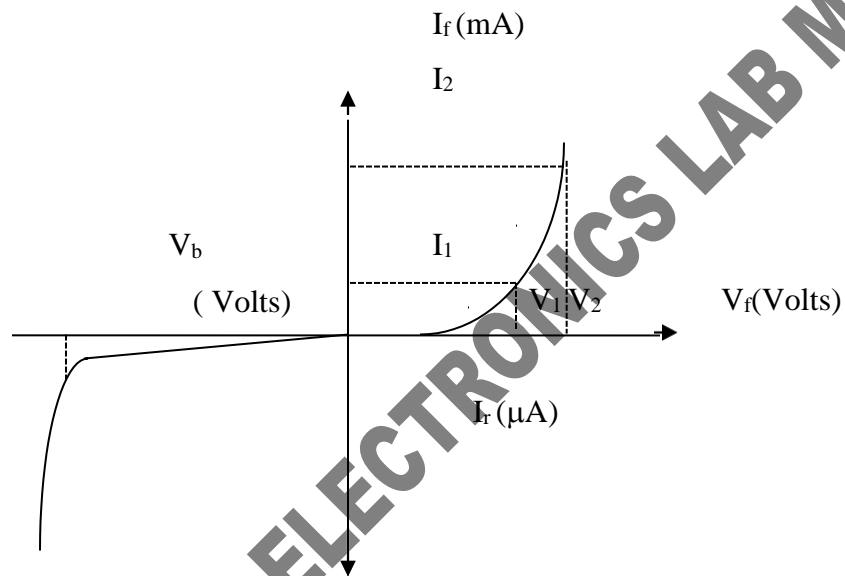

**RESULT:**

Forward and Reverse bias characteristics of the PN junction diode and the dynamic resistance under

- i) Forward bias =-----
- ii) Reverse bias =-----.
- iii) Reverse Saturation Current =-----.

## VIVA – VOCE QUESTION

### **SEMICONDUCTOR DIODE AND ZENER – DIODE**

1. Define knee voltage of diode.
2. Draw VI characteristics of PN junction diode.
3. Although Zener diode is operated in the reverse breakdown region, but it does not burn. Why?
4. Differentiate between static and dynamic resistance of diode.
5. Differentiate between avalanche and Zener breakdown.
6. Draw the VI characteristics of an ideal diode

SRM VEC EPL-ELECTRONICS LAB MANUAL



ANNA UNIVERSITY: CHENNAI – 600 025

B.E./B.Tech. DEGREE EXAMINATIONS, APRIL - 2020

Regulations - 2019

Second Semester  
(Common to All Branches)

**GE8261 ENGINEERING PRACTICES LABORATORY**  
**Group 'B' (Electronics Engineering)**

1. Verify the logical multiplication and Negation using truth table experimentally.
2. Construct a circuit to convert an AC signal to a pulsating DC signal during the positive half cycle of the input and calculate the necessary parameter experimentally.
3. Construct a circuit to convert an AC signal to a pulsating DC signal during both positive and negative half cycles of the input and calculate the Ripple factor experimentally.
4. a) Using function generator, generate 5KHZ sinusoidal signal and measure its parameters Using CRO.  
b) Find the resistance value of the given resistors (4 numbers) using color code.
5. Generate the clock signal and measure its parameters using CRO. Plot the waveform.
6. Assemble the below circuit in the given board and verify the connectivity of the circuit using multimeter and disassemble the components from the board.

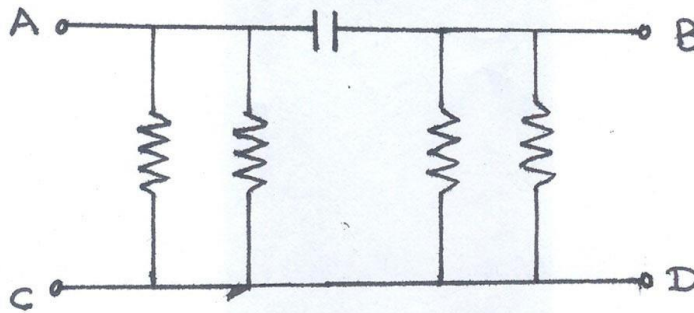

**Allotment of Marks:**

Aim, Components Required	-05
Circuit Diagram and Procedure	-15
Tabulation and Verification	-15
Graph and Result	-10
Viva-Voce	-05
Total	-50 Marks

Internal Examiner

External Examiner

