



SRM VALLIAMMAI ENGINEERING COLLEGE
(AN AUTONOMOUS INSTITUTION)
SRM NAGAR, KATTANKULATHUR – 603 203



1903306 -CONSTRUCTION MATERIALS LABORATORY
LAB INSTRUCTION MANUAL
(THIRD SEMESTER)



DEPARTMENT OF CIVIL ENGINEERING

REGULATION 2019

ACADEMIC YEAR (2021-2022)

PREFACE

This instruction manual has been prepared by the department of Civil Engineering to facilitate instructions doing practical classes and further to be used as a reference manual by the third semester Civil Engineering students of this college. This manual covers explanation of experiments included in the syllabus of the Anna University according to Regulation 2019 Construction Materials Laboratory (1903306) for the B.E Civil Engineering degree course.

Ms.K.Suganya Devi

Assistant Professor

Lab Incharge

Specific Rules and Hazards Associated with this Lab Include

Capacity-Normal Occupancy during teaching labs is 34

- Students should enter the lab with proper uniform and IDcard.
- Always keep work areas clean and tidy.
- Observe safety alerts in the laboratory.
- Always wear shoes that completely cover your feet. No sandals or opened toed shoes are allowed.
- Follow all written and verbal instructions carefully.
- Observe the safety alerts in the laboratory.
- Don't forget to bring Lab manual, Record, observation, calculator, graph sheet and other accessories when you come to lab.
- In the absence of Instructor no student shall be allowed to work in the laboratory.
- Don't use mobile phones during lab hours.
- Place tools and equipment in proper place after use.
- Turn off the power switches of weighing balance and equipments after used.
- Report to the staff if any injuries.
- Don't try to repair any faulty instruments.

OBJECTIVES:

- To facilitate the understanding of the behavior of construction materials.
- To know about the various test procedures on Fine aggregates
- To know about the various test procedures on Coarse aggregates
- To know about the various test procedures on Bricks and Blocks.
- To understand the properties of fresh concrete

I. TEST ON FINE AGGREGATES 15

1. Grading of fine aggregates
2. Test for specific gravity
3. Compacted and loose bulk density of fine aggregate

II. TEST ON COARSE AGGREGATE 15

1. Determination of impact value of coarse aggregate
2. Determination of elongation index
3. Determination of flakiness index
4. Determination of aggregate crushing value of coarse aggregate

III. TEST ON CONCRETE 15

1. Test for Slump
2. Test for Compaction factor
3. Test for Compressive strength - Cube & Cylinder

IV. TEST ON BRICKS AND BLOCKS 15

1. Test for compressive strength of bricks and blocks
2. Test for Water absorption of bricks and blocks
3. Determination of Efflorescence of bricks
4. Test on tiles

V. MIX DESIGN (DEMONSTRATION)

Different grades of Concrete

TOTAL: 60 PERIODS

OUTCOMES:

1. The students will have the required knowledge in the area of testing of construction materials.
2. Will be able to analyse components of construction elements experimentally.
3. Will be understand the quality of the construction materials experimentally.
4. Will be able to understand the properties of fresh concrete.
5. Will be able to understand the properties of hardened concrete.

REFERENCE BOOKS:

1. Construction Materials Laboratory Manual, Anna University, Chennai-600 025.
2. IS 4031 (Part 1) – 1996 – Indian Standard Method for determination of fineness by dry sieving.
3. IS 2386 (Part 1 to Part 6) – 1963 – Indian Standard methods for test for aggregate for
4. concrete
5. IS 383 – 1970 Indian Standard specification for coarse and fine aggregates from natural sources for concrete.

LIST OF EQUIPMENTS FOR A BATCH OF 30 STUDENTS

Sl.No.	Description of Equipment	Quantity
1.	Pycnometer	1
2.	Aggregate impact testing machine	1
3.	Length Gauge	1
4.	Thickness Gauge	1
5.	Aggregate Crushing Value Apparatus	1
6.	Slump cone	3
7.	Compaction Factor Apparatus	1
8.	Concrete cube moulds	6
9.	Concrete cylinder moulds	3
10.	Trovels and planers	1Set
11.	Vibrator	1
12.	Sieves	1Set

LIST OF EXPERIMENTS

EXPT.NO	EXPERIMENT NAME
I. TEST ON FINE AGGREGATES	
1.	Grading of fine aggregates
2.	Test for specific gravity
3.	Compacted and loose bulk density of fine aggregate
II. TEST ON COARSE AGGREGATE	
4.	Determination of impact value of coarse aggregate
5.	Determination of elongation index
6.	Determination of flakiness index
7.	Determination of aggregate crushing value of coarse aggregate
III. TEST ON CONCRETE	
8.	Test for Slump
9.	Test for Compaction factor
10.	Test for Compressive strength - Cube & Cylinder
IV. TEST ON BRICKS AND BLOCKS	
11.	Test for compressive strength of bricks and blocks
12.	Test for Water absorption of bricks and blocks
13.	Determination of Efflorescence of bricks
14.	Test on tiles
V. MIX DESIGN (DEMONSTRATION)	
15.	Different grades of Concrete

TEST ON FINE AGGREGATES

1. DETERMINATION OF FINENESS MODULUS OFFINE AGGREGATE

Aim:

To determine fineness modulus of fine aggregate and classifications based on IS: 383-1970.

Apparatus Required:

1. Test Sieves conforming to IS:460-1962.
2. Specification of 4.75 mm, 2.36 mm, 1.18 mm, 600 micron, 300micron, 150micron.
3. WeighBalance
4. GaugingTrowel
5. StopWatch

Procedure:

1. The sample shall be brought to an air-dry condition before weighing and sieving.
2. The air-dry sample shall be weighed and sieved successively on the appropriate sieves starting with the largest.
3. Material shall not be forced through the sieve by handpressure.
4. Lumps of fine material, if present, may be broken by gentle pressure with fingers against the side of the sieve.
5. Light brushing with a fine camel hair brush may be used on the 150-micron and 75-micron IS Sieves to prevent aggregation of powder and blinding of apertures.
6. On completion of sieving, the material retained on each sieve, together with any material cleaned from the mesh, shall be weighed.

Observation and Calculation

Weight of empty tray	=	kg
Weight of tray + fine aggregate	=	kg
Weight of fine aggregate	=	kg

IS Sieve	Weight Retained on Sieve	Percentage of Weight Retained (%)	Percentage of Weight Passing (%)	Cumulative Percentage of Passing (%)
4.75 mm				
2.36 mm				
1.18 mm				
600 micron				
300 micron				
Total				

Fineness modulus = $\frac{F}{100}$

Result:

The fineness modulus of fine aggregate is _____.

VIVA QUESTIONS

1. Fine Aggregates should pass through which IS sieve?
4.75mm IS sieve is the aggregate size deciding sieve. Anything retained on sieve is coarse aggregate and the ones that pass through sieve are fine aggregates.
2. How many types of fine aggregates are there based on source?
Three types are natural sand (river banks), crushed stone sand (hard stone) and crushed gravel sand (gravel).
3. What is the use of fineness modulus of fine aggregate?
Fineness modulus is generally used to get an idea of how coarse or fine the aggregate is. More fineness modulus value indicates that the aggregate is coarser and small value of fineness modulus indicates that the aggregate is finer.
4. What is the percentage of fine aggregate of fineness modulus?
 $Z =$ Economical value of fineness modulus for combined aggregate. The above formula will fix the proportion of fine aggregate to coarse aggregate.
The percentage of the coarse aggregate is equal to 100 minus the percentage of fine aggregate.
5. Why is the fineness modulus important?
Fineness modulus offers a way to quantify the average size of the aggregate particles in the concrete mix. The size of the particles, in turn, will greatly affect how easily the concrete pours and spreads, as well as its strength and durability once cured.
6. How do you calculate fine modulus?
Fineness modulus of sand (fine aggregate) is an index number which represents the mean size of the particles in sand. It is calculated by performing sieve analysis with standard sieves. The cumulative percentage retained on each sieve is added and subtracted by 100 gives the value of fineness modulus.
7. Is code for fineness modulus of sand?
The larger the value, the coarser is the material. Fine aggregate is classified as coarse sand, medium sand and fine sand based on the fineness modulus (IS 2386 - PART III 1963) as shown in Table 3.6. Sand having a fineness modulus more than 3.2 will be unsuitable for making satisfactory concrete.
8. Which sand is used for plastering?
Basically river sand are used for any plastering work. Generally, in any plastering work plasterers are used natural sand, crushed stone sand or crushed gravel sand. Though, there is a grading limit of sand which are used in plastering work. Other types of sand will also work, but it could be more expensive to use
9. Is M Sand good for plastering?
Plastering M Sand is used for Wall plastering and brickwork purposes. The granule thickness is 150 microns to 4.75 mm and is suitable for concrete preparations required for construction purposes. The granule thickness is 150 microns to 2.38 mm is ideal for block masonry and plastering purposes.
10. What are the disadvantages of m sand?

Crushed sand can be of coarser and angular texture. This can lead to more water and cement requirement to achieve the expected workability.

Manufactured sand can contain larger amounts of micro fine particles than natural sand, This can affect the strength and workability of the concrete.

2. DETERMINATION OF SPECIFIC GRAVITY OF FINE AGGREGATE

Aim:

To determine specific gravity of fine aggregate

Apparatus Required:

1. Pycnometer (either a Pycnometer jar with conical top or a stoppered bottle having a capacity of at least 50ml)
2. 4.75mm sieve
3. Weighing balance
4. Oven
5. Glass rod
6. Distilled water

Procedure:

1. Clean and dry the Pycnometer
2. Weigh the empty Pycnometer with its cap (W₁)
3. Take about 200 gm of oven dried soil passing through 4.75 mm sieve into the Pycnometer and weigh again (W₂)
4. Add sufficient de-aired water to cover the soil and screw on the cap
5. Shake the Pycnometer well and remove entrapped air if any
6. Fill the Pycnometer with water completely
7. Dry the Pycnometer from outside and weigh it (W₃)
8. Clean the Pycnometer by washing thoroughly
9. Fill the cleaned Pycnometer completely with water up to its top with cap screw on
10. Weigh the Pycnometer after drying it on the outside thoroughly (W₄)
11. Repeat the procedure for three samples and obtain the average value of specific gravity.

Observation and Calculation

Weight of empty Pyconometer, $W_1 =$

Weight of Pyconometer + soil sample, $W_2 =$

Weight of Pyconometer + soil sample + water, $W_3 =$

Weight of Pyconometer + water, $W_4 =$

Calculate the specific gravity of the soil, as follows,

Specific gravity = $GS = (W_2 - W_1) / (W_2 - W_1)(W_3 - W_4)$

Result:

The specific gravity of the test sample =

VIVA QUESTIONS

1. What is the significance of specific gravity test of sand?
Specific Gravity is the ratio of the weight of a given volume of aggregate to the weight of an equal volume of water. Water, at a temperature of 73.4°F (23°C) has a specific gravity of 1. Specific Gravity is important for several reasons. Some deleterious particles are lighter than the "good" aggregates.
2. What is the specific gravity of fine aggregate range as per IS code
Specific gravity of fine aggregate (sand) is the ratio of the weight of given volume of aggregates to the weight of equal volume of water. The specific gravity of sands is considered to be around 2.65.
3. What is the density of M Sand?
The Fineness modulus of river sand is 5.24. Manufactured Sand: M-Sand was used as partial replacement of fine aggregate. The bulk density of Manufactured sand was 1.75 kg/m³, specific gravity and fineness modulus was found to be 2.73 and 4.66, respectively.
4. Why specific gravity test is done?
It is used to define the weight or density of a liquid as compared to the density of an equal volume of water at a specified temperature. The temperature used for measurement is usually 39.2° F (4° C), because this temperature allows water to assume its maximum density.
5. How heavy is 1m³ of sand?
Sand, dry weighs 1.631 gram per cubic centimeter or 1 631 kilogram per cubic meter, i.e. density of sand, dry is equal to 1 631 kg/m³. In Imperial or US customary measurement system, the density is equal to 101.8 pound per cubic foot [lb/ft³], or 0.9428 ounce per cubic inch [oz/inch³].
6. What is M Sand and P sand?
If i am not mistaken, P sand stands for Plastering sand. Other types are manufactured sand(m sand), sharp sands, buildings sands etc The difference is in the size of the particles. Plastering sand will have fine grained particles, whereas manufactured sand will have little coarser particles may be
7. What is the weight of 1 CFT sand?
1 cft of sand would weigh around 45 kgs.
8. What is one unit of sand?
Equals: 35.31 **cubic feet** (cu ft - ft³) in volume. Converting **cubic foot** to cubic meters value in the beach sand units scale.

3. DETERMINATION OF COMPACTED AND LOOSE BULK DENSITY OF FINE AGGREGATE

Aim:

To determine compacted and loose bulk density of fine aggregate

Apparatus Required:

1. Weighing balance
2. Cylindrical metal measure
3. Tamping rod

1 Procedure for Compacted Bulk Density

1. Measure the volume of the cylindrical metal measure by pouring water into the metal measure and record the volume "V" in litre.
2. Fill the cylindrical metal measure about one-third full with thoroughly mixed aggregate and tamp it 25 times using tamping bar.
3. Add another layer of one-third volume of aggregate in the metal measure and give another 25 strokes of tamping bar.
4. Finally fill aggregate in the metal measure to overflowing and tamp it 25 times.
5. Remove the surplus aggregate using the tamping rod as a straight edge.
6. Determine the weight of the aggregate in the measure and record that weight "W" in kg.

Procedure for Loose Bulk Density

1. Measure the volume of the cylindrical metal measure by pouring water into the metal measure and record the volume "V" in litre.
2. Fill the cylindrical measure to overflowing by means of a shovel or scoop, the aggregate being discharged from a height not exceeding 5 cm above the top of the measure
3. Level the top surface of the aggregate in the metal measure, with a straight edge or tamping bar.
4. Determine the weight of the aggregate in the measure and record the weight "W" in kg.

Observation and Calculation

Calculation for Compacted Bulk Density

Compacted unit weight or bulk density = W/V

Where,

W = Weight of compacted aggregate in cylindrical metal measure, kg

V = Volume of cylindrical metal measure, litre

Calculation For Loose Bulk Density

Loose unit weight or bulk density = W/V

Where,

W = Weight of loose aggregate in cylindrical metal measure, kg

V = Volume of cylindrical metal measure, litre

Result:

The compacted bulk density of the given sample =

The loose bulk density of the given sample =

VIVA QUESTIONS

1. What is bulk density of fine aggregate?
If the volume is unit then, Bulk Density= Mass. Unit in kg/m^3 or lb/ft^3 . In this definition, the volume is that contain both the aggregates and the voids between aggregates particles. The approximate bulk density of aggregate that is commonly used in normal-weight concrete is between $1200\text{-}1750 \text{ kg/m}^3$ ($75\text{-}110 \text{ lb/ft}^3$).
2. Are sieves fine aggregates?
Size of sieves to be used: For fine aggregate- 4.75mm, 2.36mm, 1.18mm, 600 microns, 300 microns, 150 microns. For coarse aggregate-25mm,20mm 12.5mm, 10mm, 4.75mm.
3. Why Bulk density is important?
High bulk density is an indicator of low soil porosity and soil compaction.
4. What factors affect bulk density?
Inherent factors that affect bulk density such as soil texture cannot be changed. Bulk density is dependent on soil organic matter, soil texture, the density of soil mineral (sand, silt, and clay) and their packing arrangement.
5. How Bulk density is measured?
Bulk Density. Bulk density is the volume of powder per gram of weight in a cylinder, after 50 mechanical taps. Tap density is measured in a tapping machine containing a graduated cylinder that moves up and down. Powdered material is introduced into the cylinder.
6. What is bulk density of sand?
The bulk density or unit weight of sand is the mass or weight of the sand that required to fill a container of a specified unit volume. Bulk Density of sand = $\frac{\text{Mass of sand}}{\text{volume}}$.
Key Features: If the volume is unit then, Bulk Density= Mass. Unit in kg/m^3 or lb/ft^3 .
7. What is dry bulk density?
Background. The soil bulk density (BD), also known as dry bulk density, is the weight of dry soil (M_{solids}) divided by the total soil volume (V_{soil}). The total soil volume is the combined volume of solids and pores which may contain air (V_{air}) or water (V_{water}), or both
8. What is the mass of sand?
A grain of sand has a mass of approximately .00000003 grams.
9. What does 1 yard of sand weigh?
The approximate weight of 1 cubic yard of sand is 2,600 to 3,000 pounds. This amount is also roughly equal to 1 1/2 tons. A cubic yard of gravel will weigh slightly less, at roughly 2,400 to 2,900 pounds, or roughly still 1 1/2 tons.
10. Will 2 yards of sand fit in a pickup truck?
A regular size pick-up will hold three cubic yards of mulch (a full load). Two cubic yards is about body level full. When picking up soils, sands and gravels, one cubic yard is all that is recommended on a pick-up truck. Below is an outline of what your truck may be able to handle.

TEST ON COARSE AGGREGATES

4. DETERMINATION OF IMPACT VALUE OF COARSE AGGREGATE

Aim:

To determine the aggregate impact value of given aggregate

Apparatus Required:

1. Impact testing machine: The machine consists of a metal base. A detachable cylindrical steel cup of internal diameter 10.2 cm and depth 5 cm. A metal hammer of weight between 13.5 to 14 kg, 10 cm in diameter and 5 cm long. An arrangement for raising the hammer and allow it to fall freely between vertical guides from a height of 38 cm on the test sample in the cup
2. A cylindrical metal measure having 7.5 cm diameter and depth of 5 cm for measuring aggregates
3. A tamping rod of circular cross section, 1 cm diameter and 23 cm long, rounded at one end
4. IS sieve of sizes 12.5 mm, 10 mm and 2.36 mm
5. Balance of capacity not less than 500 gm to weigh accurate upto 0.01 gm

Procedure:

1. The test sample consists of aggregates passing 12.5 mm sieve and retained on 10 mm sieve and dried in an oven for 4 hours at a temperature of 100⁰C to 110⁰C
2. The aggregates are filled up to about 1/3 full in the cylindrical measure and tamped 25 times with rounded end of the tamping rod
3. The rest of the cylindrical measure is filled by two layers and each layer being tamped 25 times
4. The overflow of aggregates in cylindrical measure is cut off by tamping rod using its straight edge
5. Then the entire aggregate sample in measuring cylinder is weighed nearing to 0.01 gm
6. The aggregates from the cylindrical measure are carefully transferred into the cup which is firmly fixed in position on the base plate of machine. Then it is tamped 25 times
7. The hammer is raised until its lower face is 38 cm above the upper surface of aggregates in the cup and allowed to fall freely on the aggregates. The test sample is subjected to a total of 15 such blows each being delivered at an interval of not less than one second. The crushed aggregate is then removed from the cup and the whole of it is sieved on 2.36 mm sieve until no significant amount

passes. The fraction passing the sieve is weighed accurate to 0.1gm

8. Repeat the above steps with other fresh sample
9. Let the original weight of the oven dry sample be w_1 gm and the weight of fraction passing 2.36 mm IS sieve be w_2 gm. Then aggregate impact value is expressed as the % of fines formed in terms of the total weight of the sample.

Observation and Calculation

	Deails of Sample	Trail 1	Trail 2	Average
1	Total Weight of aggregate sample filling the cylinder measure = W_1 g			
2	Weight of aggregate passing 2.36mm sieve after the test = W_2 g			
3	Weight of aggregate retained 2.36mm sieve after the test = W_3 g			
4	$(W_1 - W_2 + W_3)$			
5	Aggregate Impact Value = $(W_2 / W_1) * 100$ Percent			

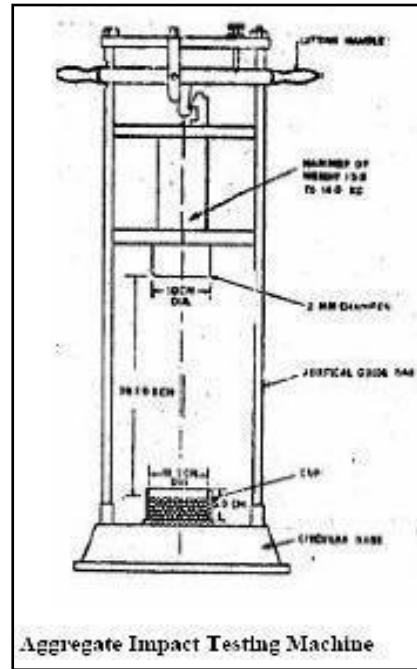

Result:

The mean aggregate impact value is %.

VIVA QUESTIONS

1. Why aggregate impact value test is done?
The aim of aggregate impact test is to determine the relative measure of the resistance of aggregate to sudden shock or impact in which in some aggregate differs from its resistance to a slowly applies compressive load. The property of a material to resist impact is known as toughness.
2. What are the uses of determining impact value?
To determine the impact value of the aggregates used in pavement construction(Road); To assess their suitability in road layers (base course, surface course) construction on the basis of impact value.
3. What is impact value?
The aggregate impact value is a measure of resistance to sudden impact or shock, which may differ from its resistance to gradually applied compressive load.
4. Why do we do impact test?
Impact test determines the amount of energy absorbed by a material during fracture. This absorbed energy is a measure of a given material's toughness and acts as a tool to study temperature-dependent brittle-ductile transition. It is to determine whether the material is brittle or ductile in nature.
5. What is aggregate toughness?
Toughness. Resistance of the aggregates to impact is termed as toughness. Aggregates used in the pavement should be able to resist the effect caused by the jumping of the steel tyred wheels from one particle to another at different levels causes severe impact on the aggregates
6. What are the types of aggregate?
The Different Types Of Aggregate. The categories of aggregates include gravel, sand, recycled concrete, slag, topsoil, ballast, Type 1 MOT, and geosynthetic aggregates (synthetic products commonly used in civil engineering projects used to stabilise terrain).
7. What are the advantages of aggregate impact test?
The advantages of aggregates impact test are that the test equipment and procedure are simple, and it can obtain the resistance and impact of stones even in field condition. The test can be done in brief period whether it is at construction site.
8. What are the test for coarse aggregate?
Crushing test.
Abrasion test.
Impact test.
Soundness test.
Shape test.
Specific gravity and water absorption test.
Bitumen adhesion test.
9. What is grading of coarse aggregate?
Grading of aggregates is determining the average grain size of the aggregates before they are used in construction. This is applied to both coarse and fine aggregates. The aggregate sample is sieved through a set of sieves and weights retained on each sieve in percentage terms are summed up.
10. What is 20mm aggregate?
It is the aggregate composed of both fine aggregate and coarse aggregate. ... For example, all in aggregate of nominal size of 20mm means an aggregate most of which passes through 20 mm IS sieve and contains fine aggregates also.

5. DETERMINATION OF ELONGATION INDEX

Aim:

To determine the Elongation index of the given aggregate sample

Apparatus Required:

1. Length gauge
2. IS sieve

Procedure:

1. The sample is sieved through IS Sieve specified in the table. A minimum of 200 aggregate pieces of each fraction is taken and weighed
2. Each fraction is thus gauged individually for length in a length gauge. The gauge length is used should be those specified in the table for the appropriate material
3. The pieces of aggregate from each fraction tested which could not pass through the specified gauge length with its long side are elongated particles and they are collected separately to find the total weight of aggregate retained on the length gauge from each fraction
4. The total amount of elongated material retained by the length gauge is weighed to an accuracy of at least 0.1% of the weight of the test sample
5. The weight of each fraction of aggregate passing and retained on specified sieve sizes are found W_1, W_2, W_3, \dots and the total weight of sample determined $= W_1 + W_2 + W_3 + \dots = W \text{ gm}$. Also the weights of the material from each fraction retained on the specified gauge length are found $= x_1, x_2, x_3, \dots$ and the total weight retained determined $= x_1 + x_2 + x_3 + \dots = X \text{ gm}$
6. The elongation index is the total weight of the material retained on the various length gauges, expressed as a percentage of the total weight of the sample gauged

$$\text{Elongation index} = \frac{(x_1 + x_2 + x_3 + \dots)}{(W_1 + W_2 + W_3 + \dots)} \times 100$$

Observation and Calculation

Size of aggregate		Length gauge	Weight of the fraction consisting of atleast 200 pieces in gm	Weight of aggregates in each fraction retained on length gauge gm
Passing through IS sieve mm	Retained on IS sieve mm			
63	50	-		
50	40	81		
40	25	58.50		
31.5	25	-		
25	20	40.5		
20	16	32.4		
16	12.5	25.6		
12.5	10	20.2		
10	6.3	14.7		



Elongation Index Test in Progress

Result:

The elongation index of a given sample of aggregate is _____ %

VIVA QUESTIONS

1. What do you infer from elongation index?
Flakiness Index is the percentage by weight of particles in it, whose least dimension (i.e. thickness) is less than three-fifths of its mean dimension. Elongation Index is the percentage by weight of particles in it, whose largest dimension (i.e. length) is greater than one and four-fifths times its mean dimension.
2. Why elongation index test is conducted?
This test is used to determine the particle shape of the aggregate and each particle shape being preferred under specific conditions. The significance of flakiness & elongation index is as follows; ... Due to high surface area to volume ratio, the flaky and elongated particles lower the workability of concrete mixes.
3. What is elongation index?
Elongation index of an aggregate is the percentage by weight of particles whose greatest dimension (length) is greater than one and four-fifth times (1.8 times or 9/5 times) their mean dimension. It is measured on particles passing through mesh size of 63mm and retained on mesh size of 6.3mm.
4. What is combined flakiness and elongation index?
Flakiness index is weight of flaky stone metal divided by. weight of stone sample. Only the elongated particles be separated out from the remaining (non-flakY) stone metal. Elongation index is weight of elongated particles divided by total non-flaky particles.
5. Is code for elongation index?
The Elongation index of an aggregate is the percentage by weight of particles whose greatest dimension (length) is greater than nine-fifths (1.8times) their mean dimension. This test is not applicable for sizes smaller than 6.3mm.
6. Coarse aggregates are classified into how many groups?
The two main groups of coarse aggregates are single-sized aggregates and graded aggregates.
7. Graded aggregate contains particles of size:
It consists of aggregates of more than one single grade. It ideally contains particles of size 4.75mm and above in a proportionate amount.
8. Which size coarse aggregate is ideal for use in a concrete mix?
Using the largest size will result in a reduction of cement, water and shrinkage in the concrete mix.
9. Gravel is a type of?
All gravel particles have an irregular shape and sharp edge. Sand has a rounded shape. Laminated rocks have flaky shape and crushed rocks have an angular shape.
10. How is percentage retained on each sieve calculated?
The percentage retained is calculated by dividing weight of sample retained by the weight of the total sample, taken in beginning of test.

6. DETERMINATION OF FLAKINESS INDEX

Aim:

To determine the flakiness index of the given aggregate sample

Apparatus Required:

1. The apparatus consist of a standard thickness gauge
2. IS Sieve of size 63, 50, 40, 31.5, 25, 20, 16, 12.5, 10 and 6.3
3. Balance to weight the samples

Procedure:

1. The sample is sieved with the sieves mentioned in the table
2. A minimum of 200 pieces of each fraction to be tested are taken and weighed (W_1 gm)
3. In order to separate flaky materials, each fraction is then gauged for thickness on the thickness gauge, or in bulk on sieve having elongated slots as specified in the table
4. Then the amount of flaky materials passing the gauge is weighed to an accuracy of at least 0.1% of test sample
5. Let the weight of the flaky materials passing the gauge be W_1 gm. Similarly the weights of the fractions passing and retained on the specified sieves be W_1, W_2, W_3 , etc, are weighed and the total weight $W_1 + W_2 + W_3 + \dots = W$ gm is found. Also the weights of the materials passing each of the specified thickness gauge are found = W_1, W_2, W_3, \dots . And the total weight of the material passing the different thickness gauges = $W_1 + W_2 + W_3 + \dots = W$ gm is found
6. Then the flakiness index is the total weight of the flaky material passing the various thickness gauges expressed as a percentage of the total weight of the sample gauged.

$$\text{Flakiness index} = \frac{(w_1 + w_2 + w_3 + \dots)}{(W_1 + W_2 + W_3 + \dots)} \times 100$$

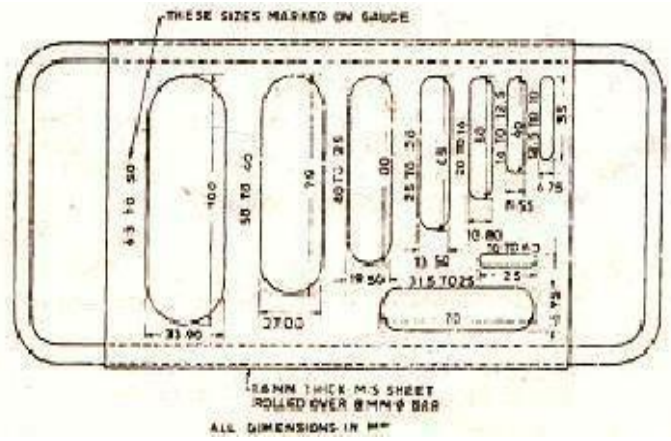

Flakiness Index Test in Progress

Size of aggregate		Thickness gauge (0.6 times the mean sieve) mm	Weight of the fraction consisting of atleast 200 pieces in gm	Weight of aggregates in each fraction passing on thickness gauge gm
Passing through IS sieve mm	Retained on IS sieve mm			
63	50	33.90		
50	40	27.00		
40	25	19.50		
31.5	25	16.50		
25	20	13.50		
20	16	10.80		
16	12.5	8.55		
12.5	10	6.75		
10	6.3	4.89		

Result:

The flakiness index of a given sample of aggregate is _____%

VIVA QUESTIONS

1. How do you find the flakiness index?
The flakiness index of an aggregate sample is found by separating the flaky particles and expressing their mass as a percentage of the mass of the sample tested. The test is not applicable to materials passing the 6.30 mm test sieve or retained on the 63.00 mm test sieve.
2. What is flakiness and elongation test?
Theory of Flakiness Index and Elongation Index Tests
The Flakiness index of aggregates is the percentage by weight of particles whose least dimension (thickness) is less than three-fifths (0.6times) of their mean dimension. This test is not applicable to sizes smaller than 6.3mm.
3. What is flakiness index test?
The Flakiness Index is the total weight of the material passing the various thickness gauges or sieves, expressed as a percentage of the total weight of the sample gauged. ... The total amount retained by the length gauge shall be weighed to an accuracy of at least 0.1 percent of the weight of the test sample.
4. Is code for flakiness index?
Aggregate Flakiness Index Value (Is:2386-Part 1-1963)
5. Why do we do flakiness index?
This test is used to determine the particle shape of the aggregate and each particle shape being preferred under specific conditions. The significance of flakiness & elongation index is as follows; ... Due to high surface area to volume ratio, the flaky and elongated particles lower the workability of concrete mixes.
6. What is the use of flakiness index and elongation index?
Flakiness Index is the percentage by weight of particles in it, whose least dimension (i.e. thickness) is less than three-fifths of its mean dimension. Elongation Index is the percentage by weight of particles in it, whose largest dimension (i.e. length) is greater than one and four-fifths times its mean dimension.
7. Flaky particles have:
Flaky particles have a small thickness compared to the dimensions of other parameters that is width and length.
8. Which of the below is a limitation of performing sieve analysis?
The shape of particles is assumed to be nearly round or spherical so that they pass through the square opening. For elongated, flaky particles it will be difficult.

7. DETERMINATION OF AGGREGATE CRUSHING VALUE OF COARSE AGGREGATE

AIM

To determine the **Aggregate Crushing Value** by compression testing machine.

APPARATUS REQUIRED:

1. Cylindrical measure and plunger,
2. Compression testing machine,
3. IS Sieves of sizes – 12.5mm, 10mm and 2.36mm



PROCEDURE

1. The aggregates passing through 12.5mm and retained on 10mm IS Sieve are oven-dried at a temperature of 100 to 110°C for 3 to 4hrs.
2. The cylinder of the apparatus is filled in 3 layers, each layer tamped with 25 strokes of a tamping rod.
3. The weight of aggregates is measured (Weight 'A').
4. The surface of the aggregates is then leveled and the plunger inserted. The apparatus is then placed in the compression testing machine and loaded at a uniform rate so as to achieve 40t load in 10 minutes. After this, the load is released.
5. The sample is then sieved through a 2.36mm IS Sieve and the fraction passing through the sieve is weighed (Weight 'B').
6. Two tests should be conducted.

$$\text{Aggregate crushing value} = (B/A) \times 100\%.$$

Result:

The Aggregate Crushing Value of coarse aggregate is _____

VIVA QUESTIONS

1. What is purpose of crushing test coarse aggregate?
Resistance of an aggregate to crushing under gradually applied compressive load.
2. What is the limit for aggregate crushing value for cement concrete pavement
Aggregate crushing value for cement concrete pavement shall not exceed 30%
3. What is the limit for aggregate crushing value for wearing surfaces
Aggregate crushing value for wearing surfaces shall not exceed 45%
4. What are the mechanical properties required in aggregate
 - i. Satisfactory resistance crushing under the roller during construction
 - ii. Adequate resistance to surface abrasion under traffic.
5. What is the significance of crushing strength of aggregate
The aggregate crushing value provides a relative measure of resistance to crushing under a gradually applied load. To achieve a high quality of pavement, aggregate possessing low aggregate crushing value should be preferred.
6. List the apparatus required for aggregate crushing test
 - a) Steel cylinder with open ends, and internal diameter 152mm, square base plate, plunger having a piston of diameter 150mm, with a hole provided across the stem of the plunger so that a rod could be inserted for lifting or placing the plunger in the cylinder.
 - b) Cylindrical measure having internal diameter of 115mm and height 180mm.
 - c) Steel tamping rod with one rounded end, having a diameter of 16mm and length 450 to 600mm.
 - d) Balance of capacity 3 kg with accuracy up to 1gm.
 - e) Compressive testing machine capable of applying load of 40 tonnes, at a uniform rate of loading of 4 tonnes per minute.
7. What is crushing strength
The capacity of a material or structure to withstand loads tending to reduce size

III. TEST ON CONCRETE

8. TEST FOR SLUMP

Aim:

To measure the consistency of concrete by using slump cone

Apparatus required:

Slump cone, tamping rod, metallic sheet.

Procedure.

1. The internal surface of the mould is thoroughly cleaned and freed from superfluous moisture and adherence of any old set concrete before commencing the test.
2. The mould is placed on a smooth, horizontal rigid and non – absorbent surface.
3. The mould is then filled in four layers each approximately $\frac{1}{4}$ of the height of the mould.
4. Each layer is tamped 25 times rod taking care to distribute the strokes evenly over the cross section. After the top layer has been rodded, the concrete is struck off level with a trowel and tamping rod.
5. The mould is removed from the concrete immediately by raising it slowly and carefully in a vertical direction.
6. This allows the concrete to subside. This subsidence is referred as slump of concrete.
7. The difference in level between the height of the mould and that of the highest point of the subsided concrete is measured. This difference in height in mm is taken as slump of concrete.
8. The pattern of slump indicates the characteristics of concrete in addition to the slump value. If the concrete slumps evenly it is called true slump. If one half of the cone slides down, it is called shear slump. In case of a shear slump, the slump value is measured as the difference in height between the height of the mould and the average value of the subsidence. Shear slump also indicates that the concrete is non-cohesive and shows the characteristic of segregation.

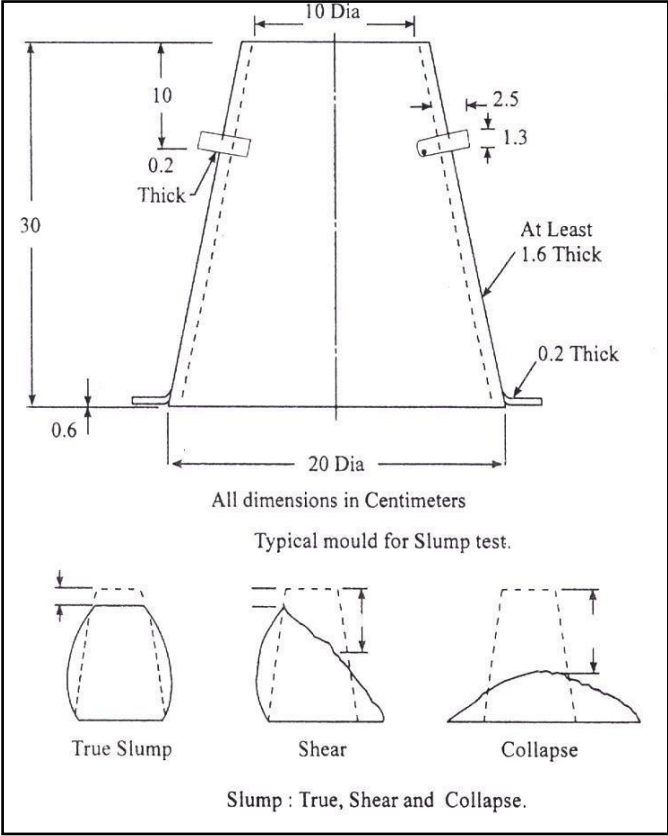

Result:

The slump value of the concrete is _____

VIVA QUESTIONS

1. Define Workability of Concrete?
Workability is often referred to as the ease with which a concrete can be transported, placed and consolidated without excessive bleeding or segregation.
2. Factors affecting workability of concrete
Water content, Size of aggregates, Surface texture of aggregate, Use of admixtures, Mix proportions, Shape of aggregates, Grading of aggregates
3. What is the significance of shear slump?
Only a true slump is of any use in the test. If a shear or collapse slump is achieved, a fresh sample should be taken and the test repeated.
4. What are the different types of Slump.
 - i. True Slump
 - ii. Shear Slump
 - iii. Collapse Slump
5. What are the differences between shear slump and collapse slump in slump test?
True slump refers to general drop of the concrete mass evenly all around without disintegration.
Shear slump indicates that the concrete lacks cohesion. It may undergo segregation and bleeding and thus is undesirable for the durability of concrete.
Collapse slump indicates that concrete mix is too wet and the mix is regarded as harsh and lean.
6. What is the significance of slump test
Slump <15mm (Non-Plastic)
Slump >15 (Plastic)
7. What is the relation between workability and slump

Workability	Compacting Factor	Slump (mm)
Very Low	0.78	0 – 25
Low	0.85	25 – 50
Medium	0.92	50 – 100
High	0.95	100 – 175
8. What are the uses of this test?
 - i. Consistency of concrete,
 - ii. Without segregation of concrete,
 - iii. Should not be a bleeding.
9. What is the purpose of this test?
To check the Consistency of concrete.
10. What is meant by true slump?
The concrete level is even.
11. What is meant by shear slump?
The level of concrete is 1.5 side down.
12. Explain about the apparatus specification for slump test.
 1. Metal mould, thickness is 1.15mm, it is in cone form with the base 200mm diameter and 300mm height with the top diameter 100mm.
 2. Tamping rod, 16mm diameter and 600mm in length having temping ends.

9.COMPACTION FACTOR TEST

Aim:

To measure the workability of concrete by compaction factor test

Apparatus required:

Compaction factor test apparatus

Procedure

- 1.The sample of concrete to be tested is placed in the upper hopper up to the brim. The trap-door is opened so that the concrete falls into the lower hopper.
- 2.Then the trap-door of the lower hopper is opened and the concrete is allowed to fall in to the cylinder. In the case of a dry-mix, it is likely that the concrete may not fall on opening the trap-door
- 3.In such a case, a slight poking by a rod may be required to set the concrete in motion. The excess concrete remaining above the top level of the cylinder is then cut off with the help of plane blades.
- 4.The outside of the cylinder is wiped clean. The concrete is filled up exactly up to the top level of the cylinder.
- 5.It is weighed to the nearest 10 grams. This weight is known as “ weight of partially compacted concrete”
- 6.The cylinder is emptied and then refilled with the concrete from the same sample in layers approximately 5cm deep. The layers are heavily rammed or preferably vibrated so as to obtain full compaction.
- 7.The top surface of the fully compacted concrete is then carefully struck off level with the top of the cylinder and weighed to the nearest 10 gm. This weight is known as “weight of fully compacted concrete”

$$\text{The compaction factor} = \frac{\text{Weight of partially compacted concrete}}{\text{Weight of fully compacted concrete}}$$

Observation and Calculation:

Mass of cylinder W1:

Sl. no	Water Cement ratio	Mass with partially compacted concrete (W2)	Mass with fully compacted concrete (W3)	Mass with Partially compacted concrete (W2 – W1)	Mass with fully compacted concrete (W3 – W1)	C.F= (W2-W1)/ (W3-W1)
1						
2						
3				33		

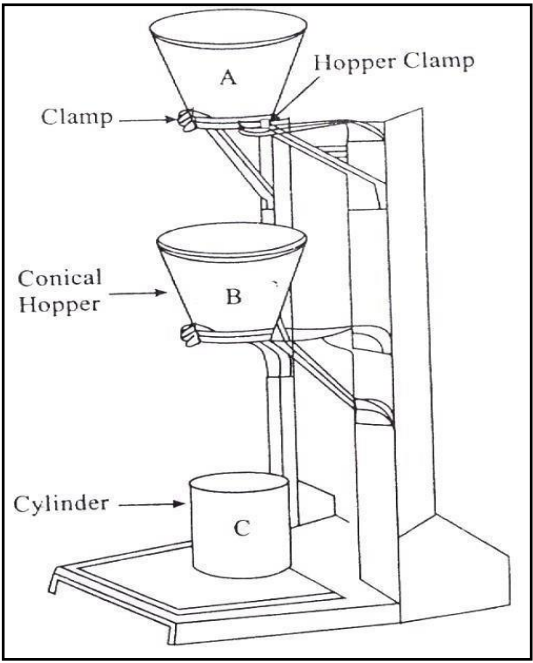

Result:

The compaction factor of the given sample of concrete is _____%

VIVA QUESTIONS

1. Define Degree of Compaction Factor.
The degree of compaction is also called the compacting factor and is measured with the help of density ratio that is the ratio of density actually achieved in the test to the density of same concrete when it is fully compacted. Its maximum answer is 1 but practically it is lesser than 1.
2. Scope & significance of Compaction Factor Test.
This test also gives the workability of concrete indirectly. This test is appropriate for concrete with the maximum aggregate size of 40mm.
3. What is the Relation Between Workability And Compacting Factor

Workability	Compacting Factor	Slump (mm)
Very Low	0.78	0 – 25
Low	0.85	25 – 50
Medium	0.92	50 – 100
High	0.95	100 – 175

4. What is meant by compaction factor?
The ratio between weight of partially compacted concrete and weight of fully compacted concrete.
5. What is the limitations of this test?
The standard limitations of 0.75 – 0.80.
6. What is the purpose of this test?
Workability of concrete, Consistency of concrete, Compaction of concrete.
7. How is based on this test?
Water content.
8. What are the safety precaution for conducting compaction factor test.
 - Use hand gloves & shoes at the time of test.
 - Equipment should be cleaned thoroughly before testing & after testing.
 - Petroleum jelly should be applied to the mould.
 - Wear the apron at the time of test.
9. What is the specification of Apparatus for Compaction factor test
It consists of two hoppers each in the shape of frustum of a cone and one cylinder. The hoppers have hinge door at the bottom and all the surfaces are polished to reduce friction.

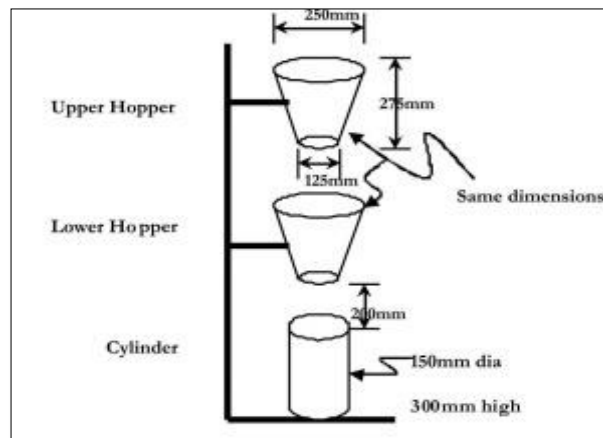

10. DETERMINATION OF COMPRESSIVE STRENGTH OF CONCRETE CUBE AND CYLINDER

Aim:

To determine the compressive strength of the hardened concrete by testing concrete cube and Cylinder

Apparatus Required:

1. Compressive testing machine of capacity 100T
2. Measuring scale
3. Cube mould of 150 mm x 150 mm size
4. Tamping rod
5. Water bath

Procedure:

A. Preparation of Specimen:

1. The mould is assembled, cleaned and the oil is applied.
2. Required quantity of ingredients and water are taken and thoroughly mixed.
3. The prepared concrete is filled in 5 cm layers and compacted in a vibrator.
4. The specimen is kept for 24 hours in the mould and then removed from the mould and immersed in water.

B. Testing of Specimen:

1. The specimen is taken out after particular days of curing
2. Measure the dimensions of the concrete cube
3. Place the concrete cube in the compression testing machine
4. Apply the load to the specimen uniformly
5. Apply further load until the specimen fails. Note down the load at failure
6. This load is the ultimate compressive load
7. Repeat the procedure for remaining specimens

Observations:

Specimen	Trials			Mean Value N/mm ²
	1	2	3	
Load on cubes, kN				

Calculation:

For Cube and Cylinder:

Formula:

For Cube and Cylinder

$$\text{Ultimate Compressive Strength} = \frac{\text{Ultimate load}}{\text{Area of Cross section}}$$

Result:

Ultimate compressive strength of concrete cube (_____ days) = _____ N/mm²

VIVA QUESTIONS

1. Explain the test method covers determination of compressive strength of cubic concrete specimens.
The compressive strength is calculated by dividing the maximum load attained during the test by the cross-sectional area of the specimen
2. What is the specimen used to this test?
The hardened concrete specimen.
3. What is the size of cube specimens?
150mmx150mmx150mm (15*15*15 cm).
4. What is the size of aggregates used test specimens?
Not less than 20 mm size of aggregates.
5. What is the purpose of compression test?
Quality, Strength of compression, Beam flexure.
6. List out the different type of moulds?
Cube, Cylindrical
7. What are the Factors affecting concrete strength?
There are many relevant factors; some of the more important follow:
 - i. Concrete porosity
 - ii. Water/cement ratio
 - iii. Soundness of aggregate:
 - iv. Aggregate-paste bond
 - v. Cement-related parameters
8. What are the Factors affecting Strength of Hardened concrete?
The strength of hardened concrete depends on many factors, the main ones being:
 - i. W/C Ratio
 - ii. Strength of the Cement
 - iii. Type and shape of Aggregate
 - iv. Entrained Air Content
9. What is the size of cylindrical specimens?
Diameter-15cm, Height-30cm

IV. TEST ON BRICKS AND BLOCKS

11. TEST FOR COMPRESSIVE STRENGTH OF BRICKS AND BLOCKS

Aim:

To determine the compressive strength of the bricks and blocks.

Apparatus Required:

1. Compressive testing machine of capacity 100T
2. Measuring scale
3. Tamping rod
4. Water bath
5. Trowel

Procedure:

1. Eight bricks are taken for the compressive strength testing.
2. The bricks are then immersed in water at room temperature for 24 hours.
3. Then these are taken out of water and surplus water on the surface is wiped off with a moist cloth.
4. The frog of the bricks is flushed level with cement mortar (1:3)
5. The bricks are stored under damp jute bags for 24 hours followed by its immersion in water at room temperature for three days.
6. The bricks are placed in the compression testing machine with flat faces horizontal and mortar filled face being upwards.
7. Load is applied at a uniform rate of 14 N/m^2 per minute till failure.

Observations:

Sl No	Load at Failure (N)	Average area of back faces (mm ²)	Compressive Strength. (N/mm ²)	Remarks

Calculation:

$$\begin{aligned} \text{Ultimate Compressive Strength} &= \frac{\text{Ultimate load}}{\text{Area of Cross section}} \\ &= \quad \quad \quad \text{N/ mm}^2 \end{aligned}$$

Result:

Ultimate compressive strength of Brickblock =N/mm²

VIVA QUESTIONS

1. Is code for compressive strength of brick?
Compressive Strength Of Brick (IS:3495-Part 1-1992)
2. Why compressive strength of brick is important?
Compressive strength test on bricks are carried out to determine the load carrying capacity of bricks under compression with the help of compression testing machine. ... Thus, it is important to know the compressive strength of bricks to check for its suitability for construction.
3. What is the compressive strength of first class brick?
[common burnt clay building bricks- specification (5th revision)]. hence minimum acceptable compressive strength of any class of burnt clay bricks in dry state is 3.5 MPa. First class bricks should not be less than 10 N/mm².
4. What is the range of compressive strength for common bricks?
Compressive strength of bricks are very variable, and may vary from 30 kg/sq. cm to 150 kg/sq. cm for hand-made burnt bricks, while compressive strength of heavy duty bricks machine pressed (also called engineering bricks) may have compressive strength as high as 450 kg/sq. cm, and even 500 kg/sq.
5. What is brick code?
The resulting common business language is clear and instantly understandable. The building block of GPC is a product code known as a brick. There are bricks for everything from a car to a bottle of milk. The highest level of the classification is a segment, which is defined as a particular industry.
6. What is the compressive strength of brick in n mm²?
Minimum crushing strength of brick is 3.50N/mm².
7. How do you check the strength of fly ash bricks?
Each brick may give different strength. Hence, average of three bricks was taken. Fly ash Bricks should not absorb water more than 12%. The bricks to be tested should be dried in an oven at a temperature of 105 to 115o C till attains constant weight cool the bricks to room temperature and weight (W1).
8. Which brick is good for construction?
There are various types of bricks such as Common Burnt Clay Bricks, Sand Lime Bricks (Calcium Silicate Bricks), Concrete Bricks, Fly ash Clay Bricks, Fire Clay Bricks and the Hollow Brick, the latest technology in bricks segment.
9. Is Brick a code test?
The Indian Standard IS 5454 : 1976 'Method for sampling of clay building bricks(first revision)' is a necessary adjunct to this standard.
10. Why bricks are tested for compressive strength?
Compressive strength test on bricks are carried out to determine the load carrying capacity of bricks under compression with the help of compression testing machine. ... These load bearing masonry structures experiences mostly the compressive loads.

12. TEST FOR WATER ABSORPTION OF BRICKS AND BLOCKS

Aim:

To determine the water absorption of the bricks and blocks.

Apparatus Required:

1. A sensitive balance capable of weighing within 0.1% of the mass of the specimen
2. Ventilated oven.

Procedure:

1. Dry the specimen in a ventilated oven at a temperature of 105°C to 115°C till it attains substantially constant mass.
2. Cool the specimen to room temperature and obtain its weight (M_1) specimen too warm to touch shall not be used for this purpose.
3. Immerse completely dried specimen in clean water at a temperature of $27 \pm 2^{\circ}\text{C}$ for 24 hours.
4. Remove the specimen and wipe out any traces of water with damp cloth and weigh the specimen after it has been removed from water (M_2).

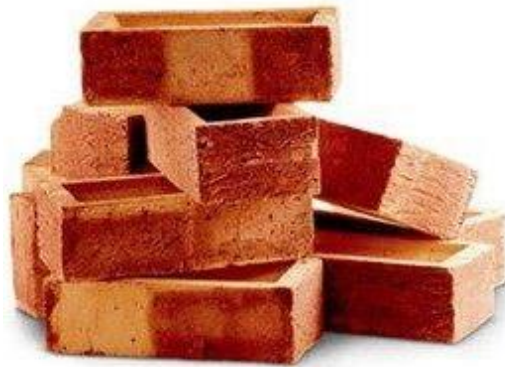

Calculation:

Water absorption, % by mass, after 24 hours immersion in cold water is given by the formula,

$$W = \frac{M_2 - M_1}{M_1} \times 100$$

Result:

Water absorption of the given bricks =%

VIVA QUESTIONS

1. What is the water absorption of brick?
The acceptable water absorption for clay bricks are between 12% and 20%.
2. Why is water absorption of bricks important?
Porosity is the ability to release and absorb moisture, and it is important and useful properties of brick.
3. What are the limits of water absorption of burnt clay bricks?
Water absorption (IS 3495 (2): 1992) of bricks should not be more than 20% by weight up to class 12.5 and 15% for higher classes when bricks are immersed in cold water for 24 hours. Efflorescence (IS 3495 (3): 1992) should not be more than 'moderate' for class up to 12.5 and 'slight' for higher classes.
4. What are the types of bricks?
Sun-Dried or Unburnt Clay Bricks. Sun-dried or unburnt bricks are less durable and these are used for temporary structures.
Burnt Clay Bricks. .
Fly Ash Bricks.
Concrete Bricks.
Engineering Bricks.
Sand Lime or Calcium Silicate Bricks.
5. How many bricks can bricklayer lay in a day?
An average experienced bricklayer can lay 4–5 bricks a minute. That's roughly 240 bricks an hour. That's about 1900 bricks a day.
6. How many courses of bricks can you lay in a day?
Working at average speeds one good bricklayer might lay 600 bricks in the day. So 1200 bricks between the gang will amount to 20m² of single skin face brickwork (60 bricks per m²).
7. Why bricks are soaked in water before use?
When brick is soaked in water, the brick absorbs water and release air so that when it is used in masonry and placed over the wet mortar, it will no more absorb any water from the wet mortar. ... Thus, it will fail to make a strong bond between bricks and mortar. Ultimately, it will make the bonding of masonry wall weak.
8. What is the weight of a hollow concrete block?
Concrete masonry Hollow Blocks are manufactured with 2150 Kg/m³ concrete density for normal weight blocks and 1100 Kg/m³ concrete density for light-weight concrete blocks. Hollow blocks are the most commonly used masonry unit.
9. Is code for hollow concrete block?
Description of item: Hollow Concrete Blocks Confirms to IS: 2185 (Part 1): 2005. This hollow Concrete Block have open or closed cavity and can be used in the construction of load-bearing and non-load bearing partition walls.
10. How do you calculate hollow blocks?
Once you have the wall measurements, calculate the square footage by multiplying the width times the height.
wall sq. ft. = width × height.
block sq. ft. = (16 × 8) ÷ 144 = . 89 sq. ft.
blocks = wall sq. ft. ÷ block sq. ft.

13. DETERMINATION OF EFFLORESCENCE OF BRICKS

Aim:

To determine the efflorescence of the bricks.

Apparatus Required:

1. A shallow flat bottom dish containing sufficient distilled water to completely saturate the specimens. The dish shall be made of glass, porcelain or glazed stoneware and of size 180 mm x 150 mm X 40 mm depth for square shaped and 200 mm diameter X 40 mm depth for cylindrical shaped.
2. Distilled water
3. Brick specimens

Procedure:

1. Fill distilled water in shallow dish and place one end of brick in dish. Water should fill in dish such that bricks should be immersed in water up to 25 mm depth.
2. Place this whole arrangement in a warm ventilated room such that whole water is absorbed by the specimen and the surplus water will get evaporated.
3. Cover the dish containing brick with suitable glass cylinder so that there will not be excessive evaporation from dish.
4. When whole water gets absorbed and brick appears to be dry, place a similar quantity of water in the dish and allow it to evaporate as before.
5. After this process examine the bricks for efflorescence and report results.



Result:

Results of efflorescence test shall be reported as nil, slight, moderate, heavy or serious.

1. Nil- If there is no noticeable deposit of efflorescence.
2. Slight- when less than 10% of exposed area of brick is covered by a thin layer of salt.
3. Moderate- When there is a heavier deposit than under 'slight' and covering up to 50 percent of the exposed area of the brick surface but unaccompanied by powdering or flaking of the surface.
4. Heavy – When there is a heavy deposit of salts covering 50 percent or more of the exposed area of the brick surface but unaccompanied by powdering or flaking of the surface.
5. Serious- when there is heavy deposit of salt acquired by powdering and/or flaking of exposed surface.

VIVA QUESTIONS

1. What is efflorescence test in Brick?
Testing Of Bricks: Efflorescence Test (IS: 3495 (Part III)): The ends of the brick are kept in a 150 mm diameter porcelain or glass dish containing 25 mm depth of water at room temperature (20 o -30 o C) till the entire water is absorbed or evaporated. ... When the deposit of efflorescence is imperceptible
2. Method of Efflorescence test?
A shallow flat bottom dish containing sufficient distilled water to completely saturate the specimens. ...
Distilled water.
Brick specimens.
3. Does efflorescence go away?
In many cases, efflorescence will disappear on its own over time (usually after the first year of a paver or retaining wall installation). Efflorescence can also be removed with special cleaners like the Gator Efflorescence Cleaner. On average, you should wait about 60 days before applying an efflorescence cleaner.
4. What does efflorescence look like?
Efflorescence is a crystalline deposit of salts that can form when water is present in or on brick, concrete, stone, stucco or other building surfaces. It has a white or greyish tint and consists of salt deposits left behind when water evaporates.
5. How is efflorescence caused?
There are many mechanisms of efflorescence, often complicated. Simply stated, efflorescence occurs when water containing dissolved salts is brought to the surface of masonry, the water evaporates and the salts are left on the surface.
6. Does vinegar remove efflorescence?
Vinegar and water solution—Efflorescence can be removed by using a dilute solution of household white vinegar and water. ... Dilution ratio is 20–50% vinegar in water by volume. For most cases of efflorescence a 25% solution works well.
7. Is efflorescence a problem?
Efflorescence alone does not pose a major problem, but it can be an indication of moisture intrusion, which may compromise the structural material.
8. Should I worry about efflorescence?
Ultimately, efflorescence itself isn't dangerous. However, it can lead to potential moisture problems that can cause structural damage to building materials. That means if you notice efflorescence in the basement or on concrete and other structures, it's important to take action.
9. How do you stop efflorescence?
Clear water repellents, silicone and acrylic coatings also may help you remove efflorescence as well. The coating will absorb water across a masonry surface and prevent efflorescence from recurring. Plus, the combination of warm water and white wine vinegar has been shown to eliminate efflorescence
10. How long does it take for efflorescence to disappear?
Efflorescence can also be removed with special cleaners like the Gator Efflorescence Cleaner. On average, you should wait about 60 days before applying an efflorescence cleaner.

14. TEST ON TILES

Aim:

To determine the water absorption and bulk density of tiles.

Apparatus Required:

1. Oven – capable of maintaining temp of about 110°C
2. Balance – accurate to 0.01% of the mass of test specimen
3. Waterbath
4. Desiccators
5. Chamois leather
6. Wirebasket

Preparation of Sample

1. A test sample consists of 10 numbers of whole tiles. If the surface area of individual tile specimen is greater than 0.04m^2 , then the numbers of tile specimens in a sample can be reduced to 5.
2. When the mass of each individual tile is below 50g, then take sufficient number of tiles, so that each test specimen weighs 50g to 100g.
3. If the dimension of tile is longer than 200 mm, then it may be cut up, but include the cut pieces in the measurement.

Test Procedure

1. Dry the tiles in the oven at $110 \pm 5^\circ\text{C}$, until it attains constant mass, i.e. when the difference between two successive weighing at intervals of 24 h is less than 0.1%.
2. Cool the tiles in the desiccators over silica gel, until cooled to room temperature.
3. Weigh each tile specimen and record the weight of individual test specimen (i.e. **m₁**) in the observation sheet.
4. Place the tiles vertically, with no contact between them, in water in the waterbath so that there is a depth of 50 mm water above and below the tiles. Maintain the water level 50 mm above the tiles throughout the test.
5. Heat the water until boiling and continue to boil for 2h. After 2h, switch off the source of heat and allow the tiles to cool, still completely immersed in this water, overnight.

6. Remove the tiles from the water bath and remove the surface water from the tile pieces by a hamois leather.
7. Immediately weigh each tile and record the weight (i.e. **m2**) in the observation sheet.
8. Now place the specimen in the wire basket that is immersed in water and determine the weight of each specimen to the nearest 0.01 g.

Calculation

1. Water Absorption

For each tile, calculate the water absorption in percentage (to the first decimal place) of the dry mass using the following formula.

$$\text{Water absorption (\%)} = [(m_2 - m_1) / m_1] * 100$$

Where,

m_1 = mass of the dry tile, in g m_2 = mass of the wet tile, in g

Calculate the average water absorption of the sample as the average of the individual result.

2. Bulk Density

Bulk density (B), in g/cm^3 , of a specimen is the ratio of its dry mass divided by the exterior volume, including pores. Calculate bulk density of tile as follow.

$$B = m_1 / V$$

Where,

B = bulk density of tile, g/cm^3 m_1 = mass of dry tile, g

V = exterior volume, in cm^3 : = (**$m_2 - m_3$**)

m_3 = mass of suspended tile impregnated by boiling water method, in g

Calculate the average bulk density of the sample as the average of the individual result.

Result:

Water absorption of the given tiles = %

Bulk density of the given sample =

VIVA QUESTIONS

1. What is water absorption of tiles?
Porcelain tile is categorized as “impervious,” which means it has a water absorption rate of less than 0.5%.
2. How is breaking strength of tile calculated?
The breaking strength is the force obtained by multiplying the breaking load by the ratio (span between the support rods / width of the test specimen).
3. How can you tell if a tile is vitrified or ceramic?
Ceramic tile is made up of earthen clay and water. Whereas the term vitrified means to convert into the glass-like substance, in this process of vitrification 40% clay and 60% silica is added. Vitrified tiles are made by a mixture of clay, silica, quartz and feldspar which is a constituent-minerals in the granite rock.
4. Does porcelain tile absorb water?
Porcelain tile is categorized as “impervious,” which means it has a water absorption rate of less than 0.5%. ... Vitreous (High Density) – Tile with water absorption of more than 0.5 percent, but not more than 3.0 percent. Impervious (Extremely dense) –Tile with water absorption of 0.5 percent or less.
5. Is ceramic tile waterproof?
While you might be using ceramic tiles in your bathroom under the belief that they are waterproof, the truth is that they actually aren't fully waterproof.
6. Which tile is best for flooring?
Porcelain and glazed ceramic tiles are the best tile flooring options for durability. They are equally easy to maintain. The tile grout needs periodic sealing to renew its look and prevent stains, especially if you rent your property.
7. Is porcelain tile slippery when wet?
While porcelain tiles technically are a subset of ceramics, they are often referred to as porcelains because they are denser, stronger and tend to look nicer.
8. Which Colour is best for floor tiles?
White, sand, beige, cream, etc are all good choices. Marble or ceramic/porcelain would also be a good match for this application.
9. Does vinegar shine tile floors?
Vinegar is a natural, non-toxic product that safely deodorizes, disinfects and cleans most hard surfaces.
10. What bathroom tile is the most popular?
Vinyl is the most popular bathroom flooring material, because of its low cost and practicality. It offers safety, comfort, and ease of maintenance, and is available in a variety of looks.

V. MIX DESIGN (DEMONSTRATION)

STEP-1. DESIGN SPECIFICATIONS

This is the step where we gather all the required information for designing a concrete mix from the client. The data required for mix proportioning is as follows.

- Grade designation (whether M10, M15, M20 etc)
- Type of cement to be used
- Maximum nominal size of aggregates
- Minimum & maximum cement content
- Maximum water-cement ratio
- Workability
- Exposure conditions (As per IS-456-Table-4)
- Maximum temperature of concrete at the time of placing
- Method of transporting & placing
- Early age strength requirement (if any)
- Type of aggregate (angular, sub angular, rounded etc)
- Type of admixture to be used (if any)

STEP-2. TESTING OF MATERIALS

The table given below shows the list of most necessary tests to be done on cement, coarse aggregate, fine aggregate and admixture. After doing the test, store the test data for further calculation.

Concrete Ingredients	Tests to be done			
Cement	Specific gravity	—	—	—
Coarse aggregate	Specific gravity	Water absorption	Free surface moisture	Sieve analysis
Fine aggregate	Specific gravity	Water absorption	Free surface moisture	Sieve analysis
Admixture (if any)	Specific gravity	—	—	—

STEP-3. TARGET STRENGTH CALCULATION

Calculate the target compressive strength of concrete using the formula given below.

$$f_{ck}' = f_{ck} + 1.65s$$

Where,

$$f_{ck}' = \text{Target compressive strength at 28 days in N/mm}^2.$$

f_{ck} = Characteristic compressive strength at 28 days in N/mm^2 . (same as grade of concrete, see table below)

s = Standard deviation

The value of standard deviation, given in the table below, can be taken for initial calculation.

Sl.No	Grade of Concrete	Characteristic compressive strength (N/mm^2)	Assumed standard deviation (N/mm^2)
1.	M10	10	3.5
2.	M15	15	
3.	M20	20	4.0
4.	M25	25	
5.	M30	30	5.0
6.	M35	35	
7.	M40	40	
8.	M45	45	
9.	M50	50	
10.	M55	55	

STEP-4. SELECTION OF WATER-CEMENT RATIO

For preliminary calculation, water cement ratio as given in IS-456-Table 5 (also given below) for different environmental exposure condition, may be used.

Note: Use **Table-1** for finding out water-cement ratio of **Plain Concrete** and use **Table-2** for finding out water-cement ratio of **Reinforced Concrete**.

Sl.No.	Environmental Exposure Condition	<u>Plain Concrete</u>		
		Minimum Cement Content (kg/m^3)	Maximum Free Water-Cement Ratio	Minimum Grade of Concrete
1	Mild	220	0.60	—
2	Moderate	240	0.60	M15
3	Severe	250	0.50	M20
4	Very Severe	260	0.45	M20
5	Extreme	280	0.40	M25

Table -2

Sl.No.	Environmental Exposure Condition	<u>Reinforced Concrete</u>		
		Minimum Cement Content (kg/m ³)	Maximum Free Water-Cement Ratio	Minimum Grade of Concrete
1	Mild	300	0.55	M20
2	Moderate	300	0.50	M25
3	Severe	320	0.45	M30
4	Very Severe	340	0.45	M35
5	Extreme	360	0.40	M40

Refer the table given below (As per IS-456) to choose right type of environment depending upon

different exposure conditions to concrete.

Sl.No	Environment	Exposure condition
1	Mild	Concrete surfaces protected against weather or aggressive conditions, except those situated in coastal areas.
2	Moderate	Concrete surfaces sheltered from severe rain or freezing whilst wet Concrete exposed to condensation and rain Concrete continuously under water Concrete in contact or buried under non aggressive soil/ground water Concrete surfaces sheltered from saturated salt air in coastal area
3	Severe	Concrete surfaces exposed to severe rain, alternate wetting and drying or occasional freezing whilst wet or severe condensation Concrete completely immersed in sea water Concrete exposed to coastal environment
4	Very severe	Concrete surfaces exposed to sea water spray, corrosive fumes or severe freezing condition whilst wet Concrete in contact with or buried under aggressive sub-soil/ground water
5	Extreme	Surface members in tidal zone Members in direct contact with liquid/solid aggressive chemicals

STEP-5. SELECTION OF WATER CONTENT

Selection of water content depends upon a number of factors such as

- Aggregate size, shape & texture
- Workability
- Water cement ratio
- Type of cement and its amount
- Type of admixture and environmental conditions.

Factors that can reduce water demand are as follows

- Using increased aggregate size
- Reducing water cement ratio
- Reducing the slump requirement
- Using rounded aggregate
- Using water reducing admixture

Factors that can increase water demand are as follows

- Increased temp. at site
- Increased cement content
- Increased slump
- Increased water cement ratio
- Increased aggregate angularity
- Decrease in proportion of the coarse aggregate to fine aggregate

The quantity of maximum mixing water per unit volume of concrete may be selected from the table given below.

Maximum water content per cubic meter of concrete for nominal maximum size of aggregate		
Sl.No.	Nominal maximum size of aggregate	Maximum water content
1	10	208
2	20	186
3	40	165

The values given in the table shown above is applicable only for angular coarse aggregate

and for a slump value in between 25 to 50mm.

Do the following adjustments if the material used differs from the specified condition.

Type of material/condition	Adjustment required
----------------------------	---------------------

For sub angular aggregate	Reduce the selected value by 10kg
For gravel with crushed stone	Reduce the selected value by 20kg
For rounded gravel	Reduce the selected value by 25kg
For every addition of 25mm slump	Increase the selected value by 3%
If using plasticizer	Decrease the selected value by 5-10%
If using super plasticizer	Decrease the selected value by 20-30%

Note: Aggregates should be used in saturated surface dry condition. While computing the requirement of mixing water, allowance shall be made for the free surface moisture contributed by the fine and coarse aggregates. On the other hand, if the aggregate are completely dry, the amount of mixing water should be increased by an amount equal to moisture likely to be absorbed by the aggregate

STEP-6. CALCULATING CEMENTIOUS MATERIAL CONTENT

From the water cement ratio and the quantity of water per unit volume of cement, calculate the amount of cementious material. After calculating the quantity of cementious material, compare it with the values given in the table shown in Step-4. The greater of the two values is then adopted.

If any mineral admixture (such as fly ash) is to be used, then decide the percentage of mineral admixture to be used based on project requirement and quality of material.

STEP-7. FINDING OUT VOLUME PROPORTIONS FOR COARSE AGGREGATE & FINE AGGREGATE

Volume of coarse aggregate corresponding to unit volume of total aggregate for different zones of fine aggregate is given in the following table.

Sl.No.	Nominal Maximum Size of Aggregate (mm)	Volume of coarse aggregate per unit volume of total aggregate for different zones of fine aggregate			
		Zone IV	Zone III	Zone II	Zone I
1	10	0.50	0.48	0.46	0.44
2	20	0.66	0.64	0.62	0.60

3	40	0.75	0.73	0.71	0.69
---	----	------	------	------	------

The values given in the table shown above is applicable only for a water-cement ratio of 0.5 and

based on aggregates in saturated surface dry condition.

If water-cement ratio other than 0.5 is to be used then apply correction using the rule given below.

Rule: For every increase or decrease by 0.05 in water-cement ratio, the above values will be decreased or increased by 0.01, respectively.

If the placement of concrete is done by a pump or where is required to be worked around congested reinforcing steel, it may be desirable to reduce the estimated coarse aggregate content determined as above, upto 10 percent.

After calculating volume of coarse aggregate, subtract it from 1, to find out the volume of fine aggregate.

STEP-8. MIX CALCULATIONS

The mix calculations per unit volume of concrete shall be done as follows.

a	Volume of concrete=	1m ³
b	Volume of cement=	(Mass of cement/specific gravity of cement)*(1/1000)
c	Volume of water=	(Mass of water/specific gravity of water)*(1/1000)
d	Volume of admixture=	(Mass of admixture/specific gravity of admixture)*(1/1000)
e	Volume of total aggregate (C.A+F.A)=	[a-(b+c+d)]
f	Mass of coarse aggregate=	e*Volume of coarse aggregate*specific gravity of coarse aggregate*1000
g	Mass of fine aggregate=	e*Volume of fine aggregate*specific gravity of fine aggregate*1000

STEP-9. TRIAL MIX

Conduct a trial mix as per the amount of material calculated above.

STEP-10. MEASUREMENT OF WORKABILITY (BY SLUMP CONE METHOD)

The workability of the trial mix no.1 shall be measured. The mix shall be carefully observed for freedom from segregation and bleeding and its finishing properties.

STEP-11. REPEATING TRIAL MIXES

If the measured workability of trial mix no.1 is different from stipulated value, the water and/or admixture content shall be adjusted suitably. With this adjustment, the mix proportion shall be recalculated keeping the free water-cement ratio at pre-selected value.

Trial-2 – increase water or admixture, keeping water-cement ratio constant

Trial-3 – Keep water content same as trial-2, but increase water-cement ratio by 10%.

Trial-4 – Keep water content same as trial-2, but decrease water-cement ratio by 10%

Trial mix no 2 to 4 normally provides sufficient information, including the relationship between compressive strength and water-cement ratio.

TOPIC BEYOND SYLLABUS

FLOW TABLE TEST

Aim:

To measure the flow and workability of the concrete by using flow table

Apparatus required:

Flow table test apparatus

Procedure.

The apparatus consists of flow table about 76cm. in diameter over which concentric circles are marked. A mould made from smooth metal casing in the form of a frustum of a cone is used with the following internal dimensions. The base is 25cm. in diameter upper surface 17cm. in diameter and height of the cone is 12cm.

1. The table top is cleaned of all gritty material and is wetted. The mould is kept on the center of the table, firmly held and is filled in two layers.
2. Each layer is rodded 25 times with a tamping rod 1.6cm in diameter and 61cm long rounded at the lower tamping end.
3. After the top layer is rodded evenly the excess of concrete which has overflowed the mould is removed.
4. The mould is lifted vertically upward and the concrete stands on its own without support. The table is then raised and dropped 12.5cm 15times in about 15 seconds.
5. The diameter of the spread concrete is measured in about 6 directions to the nearest 5mm and the average spread is noted. The flow of concrete is the percentage increase in the average diameter of the spread concrete over the base diameter of the mould.
6. The value could range anything from 0 to 150 per cent. A close look at the pattern of spread of concrete can also give a good indication of the characteristics of concrete such as tendency for segregation.

$$\text{Flow, per cent} = \frac{\text{Spread diameter in cm} - 25}{25} \times 100$$

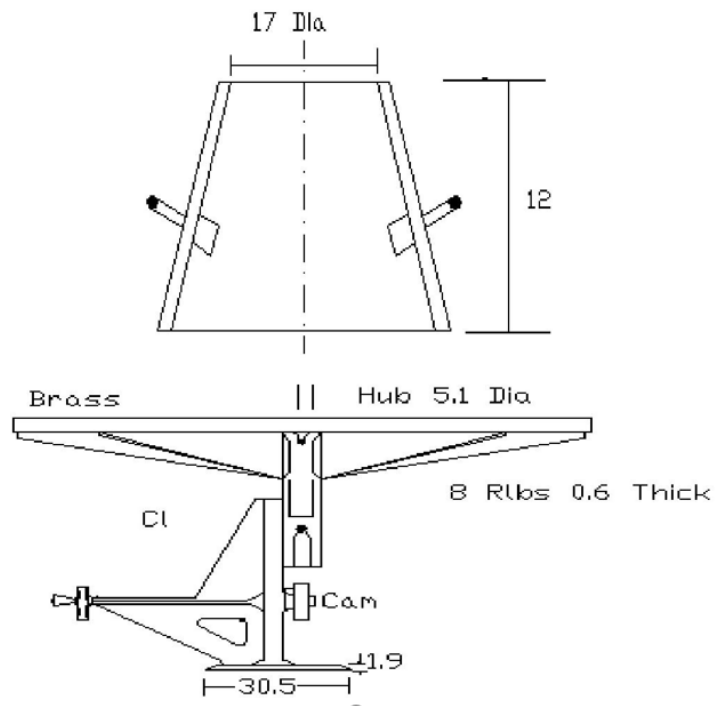

Result:

The flow percent of the concrete is

VEE-BEE CONSISTOMETER

Aim:

To measure the workability of concrete by vee-bee consistometer test

Apparatus required:

Vee-Bee consistometer test apparatus

Procedure.

- 1) Placing the slump cone inside the sheet metal cylindrical pot of the consistometer.
- 2) The glass disc attached to the swivel arm is turned and placed on the top of the concrete pot
- 3) The electrical vibrator is switched on and simultaneously a stop watch is started.
- 4) The vibration is continued till such a time as the conical shape of the concrete disappears and the concrete assumes cylindrical shape.
- 5) Immediately when the concrete fully assumes a cylindrical shape, the stop watch is switched off. The time required for the the shape of concrete to change from slump cone shape to cylindrical shape in seconds is known as vee bee degree.

Observation and Calculation:

Initial reading on the graduated rod, a		
Final reading on the graduated rod, b		
Slump (b) – (a), mm		
Time for complete remoulding, seconds		

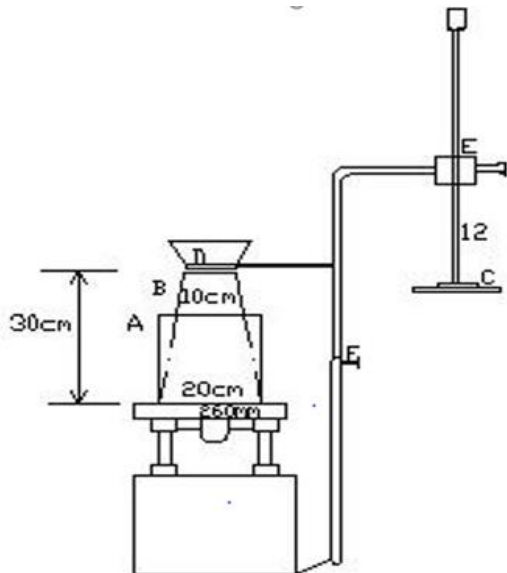

- A= cylindrical pot
- B= sheet metal cone
- C= glass disc
- D= swivel arm
- E=glass disc adjustable screw
- F= adjustable screw

Result:

The consistency of the concrete is _____ sec.

