

1909514 - THERMAL ENGINEERING LABORATORY



SRM VALLIAMMAI ENGINEERING COLLEGE



(An Autonomous Institution)

SRM Nagar, Kattankulathur-603 203.

DEPARTMENT OF MECHANICAL ENGINEERING

1909514 - THERMAL ENGINEERING LABORATORY

MANUAL

REGULATION : 2019

ACADEMIC YEAR : 2021 - 2022

Name :

Reg. No. :

Branch :

Year & Sem. :

INDEX

Exp. No.	Title	Page No.
1	Safety Regulations	2
2	Syllabus - List of Experiments	3
3	List of Equipments	4
4	Cycle of Experiments	5
5	Valve timing diagram for a four stroke diesel engine	6
6	Port timing diagram for a two stroke petrol engine	11
7	Performance test on 4 stroke diesel engine with mechanical loading	14
8	Actual P - V diagrams of a four - stroke diesel engine with electrical loading	18
9	Heat balance test on a four - stroke diesel engine	22
10	Morse test on multicylinder petrol engine.	29
11	Retardation test to find frictional power of a diesel engine.	33
12	Determination of viscosity - Red wood viscometer	38
13	Determination of flash point and fire point of various fuels / lubricants.	42
14	Study of steam generators (boiler) and turbines.	45
15	Performance test on boiler.	58
16	Performance test on steam turbine	62
	Additional experiments	
17	Performance test on centrifugal blower	68
18	Study and practical demonstration on twin cylinder diesel engine with waste heat recovery system	73
19	Dis-assembly and assembly of an engine	75
20	Multiple choice question for competitive exams and gate exam	78

1909514 - THERMAL ENGINEERING LABORATORY

SAFETY REGULATIONS

Users of Thermal Engineering Lab must comply with the following safety instructions.

1. Wear always pants and safety shoes when you operate any engine. Sandals are not allowed at all.
2. There should be no over-crowding.
3. Make sure that you stay away from hot exhaust lines and moving parts of engines
4. Before operating any machine, you must be aware of the following
 - a. Location of fire extinguishers and the outside exits.
 - b. How the engine operates. Read instruction or manual before operating it.
 - c. How to turn off the engine in case of damages.
5. When you hear or see a danger alarm from the engine that you using, stop the engine immediately.
6. Make sure that there is no fuel or oil spill on the floor.
7. Consult the instructor for safety precautions to be followed.
8. Do not run inside the lab and concentrate on the present task.
9. When moving heavy equipments or gas cylinders, use carts
- 10 Always use the right tools for the given task.
11. Handle the tools and equipments with extreme care and return the tools to their proper places (Tool Cabinets).
- 12 For cleaning tools or equipments, use only the proper cleaner. Never use fuels such as gasoline or diesel for cleaning.
13. Handle fuels with extreme caution.
 - a. Use the designated area for this purpose.
 - b. Use the proper containers (safety cans) to carry fuels.
 - c. Make sure there is no electric spark present.
 - d. Do not leave fuels in open containers.
14. Make sure that all gas cylinders are chained and well supported.
15. Before operating engine, make sure that there is no fuel or gas leakage

1909514 - THERMAL ENGINEERING LABORATORY

1909514

THERMAL ENGINEERING LAB

L T P C

0 0 4 2

LIST OF EXPERIMENTS (60 PERIODS)

COURSE OUTCOMES:

Upon the completion of this course the students will be able to:

1. Recognize the components and conduct the performance test on internal combustion engines.
2. Analysis the performance test on steam power cycles in boiler and formulate its efficiency.
3. Resolve the problems involving steam nozzles and steam turbines.
4. Compare the working and performance of petrol and diesel engines.
5. Estimate the various properties of lubrication oils.

Engine Lab

1. Valve Timing and Port Timing Diagrams.
2. Actual p-v diagrams of IC engines
3. Performance Test on 4-stroke Diesel Engine.
4. Heat Balance Test on 4-stroke Diesel Engine.
5. Morse Test on Multicylinder Petrol Engine.
6. Retardation Test to find Frictional Power of a Diesel Engine.
7. Determination of Flash Point and Fire Point of various fuels / lubricants.
8. Determination of Viscosity – using Red Wood Viscometer.

Steam Lab

1. Study and demo of Steam Generators and Turbines.

1909514 - THERMAL ENGINEERING LABORATORY

LIST OF EQUIPMENT

(For a batch of 30 students)

- | | | |
|----|---|-------|
| 1. | I.C Engine – 2 stroke and 4 stroke model. | 1 set |
| 2. | Red Wood Viscometer. | 1 No. |
| 3. | Apparatus for Flash and Fire Point. | 1 No. |
| 4. | 4-stroke Diesel Engine with mechanical loading. | 1 No. |
| 5. | 4-stroke Diesel Engine with hydraulic loading. | 1 No. |
| 6. | 4-stroke Diesel Engine with electrical loading with data Acquisition. | 1 No. |
| 7. | Multi-cylinder Petrol Engine. | 1 No. |
| 8. | Data Acquisition system with any one of the above engines. | 1 No. |
| 9. | Steam Boiler with turbine setup. | 1 No. |

CO	PO												PSO			
	1	2	3	4	5	6	7	8	9	10	11	12	1	2	3	4
1	3	3		3		2	2	1					3	3		
2	3	3		3		2	2	1					3	3		
3	3	3		3		2	2	1					3	3		
4	3	3		3		2	2	1					3	3		
5	3	3		3		2	2	1					3	3		

1909514 - THERMAL ENGINEERING LABORATORY

CYCLE OF EXPERIMENTS

CYCLE - 1

Engine Lab

1. Valve Timing and Port Timing Diagrams.
2. Actual p-v diagrams of IC engines
3. Performance Test on 4-stroke Diesel Engine.
4. Heat Balance Test on 4-stroke Diesel Engine.
5. Morse Test on Multicylinder Petrol Engine.

CYCLE - II

6. Retardation Test to find Frictional Power of a Diesel Engine.
7. Determination of Viscosity – Red Wood Viscometer.
8. Determination of Flash Point and Fire Point of various fuels / lubricants.

Steam Lab

9. Study and demo of Steam Generators and Turbines.

ADDITIONAL EXPERIMENTS

1. Performance test on Kirloskar AV-I diesel Engine with various Injection Pressure.
2. Load test on 4-stroke single cylinder Kirloskar KC-35 petrol engine.
3. Performance test / Load test on Kirloskar AV-II twin cylinder diesel Engine.
4. Find the overall heat transfer co-efficient and effectiveness on Alto-800 radiator.
5. Find the overall heat transfer co-efficient and effectiveness on spiral tube heat exchanger.

1909514 - THERMAL ENGINEERING LABORATORY

EXP. NO.:

DATE:

VALVE TIMING DIAGRAM FOR A FOUR STROKE DIESEL ENGINE

AIM:

To study the cut section of a given four stroke single cylinder, high speed diesel engine mechanism and to draw the valve timing diagram.

APPARATUS REQUIRED:

1. Four stroke diesel engine test rig, 2. Measuring tape and 3. Chalk.

DESCRIPTION:

The four stroke engine has two valves namely Inlet valve and Exhaust valve. The cycle of operation is completed in two revolutions of the crank shaft.

During suction stroke, only air is charged into the cylinder. Theoretically this stroke is executed for 180° of crank shaft rotation. In actual practice the suction stroke starts before TDC and continues few degrees of crank rotation after BDC. It inter connects the piston and crank shaft & transmit the gas forces from the piston to the crank shaft.

Crank Shaft:

It converts the reciprocating motion of the piston into useful rotary motion. The balancing mass are provided on the crank shaft for static, dynamic balancing of the rotating system.

Piston Rings:

Fitted into the slots rounded the piston to provided a tight seal between the piston and cylinder walls, thus preventing leakages of combustion gases.

Cam Shaft:

The cam shaft and its associated parts control the opening & closing of the 2 valves . The associated parts are push rods, rocker arms, valve springs and tappets. The cam shaft is driven by crank shaft then timing gear.

Fly Wheel:

In order to achieve a uniform torque and inertia in the form of a wheel is attached to the o/p shaft and this wheel is called fly wheel.

1909514 - THERMAL ENGINEERING LABORATORY

Working of a Four Stroke Diesel Engine:

The actual cut section of four stroke diesel engine is shown in figure. The working cycle of the engine is completed in 4 stroke and diesel oil is used as fuel there force is known as 4 stroke diesel engine. The following strokes are take place during the operation of engine.

Suction Stroke:

At the beginning of suction the piston is at TDC & readily to draw fresh air inside the cycle. During this stroke inlet valve is open and exhaust valve is closed. As the piston moves down wards fresh air enter thus the cylinder then the inlet valve due to the suction creates.

Compression Stroke:

During this stroke the inlet & exhaust valve are closed & the piston moves upward and compressed the air in the cylinder. Due to compression the temperature of air will rise to 1000°C, this temp is enough to ignite the fuel.

Expansion Stroke:

During this stroke inlet & exhaust valve are closed and the fuel nozzle opens just by the beginning of the stroke. The combustion of fuel is continued at constant pressure. The high pressure and temperature gases push the piston down towards BDC.

Exhaust Stroke:

During this stroke inlet valve remains closed and exhaust valve remains opened the piston moves up and pushes the burnt gas.

Effects of Valve Timings:

In compression ignition engine the valve overlap at top dead center is often limited by the piston to the cylinder head clearance. Also the inlet valve has to closed, soon after BDC the reduction in compression may cause. The exhaust valve opens before BDC. This ext oil lights in the power stroke 40° to BDC rep only 12% of the engine stroke. It should also be remembered that so after starting to open the valve may be 1% of fuel open after 10°, 5% of fully open & not fully open until 120° after starting to open, figure shows model - valve timing diagram.

Test Rig Specifications:

Engine Type: Four Stroke High Speed Single Cylinder Vertical Diesel Engine.

Ignition : Compression Ignition .

1909514 - THERMAL ENGINEERING LABORATORY

PROCEDURE:

1. Determination of BDC and TDC:

The flywheel is rotated and when the piston reaches the top most position of the cylinder a mark is made on the flywheel against a fixed reference mark. This shows the TDC on the flywheel and diametrically opposite point is the BDC.

2. Identification of the Valves:

The valves can be identified as follows. The valve that is situated in the intake manifold is the inlet valve and the other is the exhaust valve.

3. Correct Direction of Rotation:

The flywheel is rotated in an arbitrary direction. If the exhaust valve opens after nearly one revolution of the flywheel after the closure of the inlet valve it is the correct direction of rotation.

4. Timing of valve opening and closing:

The flywheel is rotated in the correct direction of rotation. A bit of paper is introduced in the tappet clearance. When the paper is just gripped, it is the opening of the valve and a mark is made on the flywheel against the chosen reference mark. The rotation is continued until the paper just released. A mark on the flywheel against the reference mark. This is the closing point of the valve. The arc lengths for the various timings for the nearest dead center are measured on the flywheel.

PRECAUTIONS:

1. Readings should be taking without parallax error
2. Observe carefully the valves are closed or in open

FORMULA USED:

The arc length of the respective points can be converted into angles using the following formula & tabulated the valves.

$$Angle = \frac{360 * X}{L}$$

where

L - Circumference of flywheel equal to $2\pi r$

r – Radius of the flywheel in ‘cm ‘

X – Arc length of the corresponds measure from TDC or BDC in cm.

Tabulation for Valve Timing Diagram:

1909514 - THERMAL ENGINEERING LABORATORY

Sl. No.	Name of the Port	Before/After TDC/BDC	Arc Length (cm)				Angle (θ) Degree
			A (cm)	B (cm)	C (cm)	Average (X) = (a+b+c)/3 (cm)	
1.	Inlet Valve Opens						
2.	Inlet Valve Closes						
3.	Exhaust Valve Opens						
4.	Exhaust Valve Closes						

RESULT:

Thus, the section of four stroke diesel engine was studied and the valve timing diagram was drawn.

VIVA QUESTIONS AND ANSWERS

1. Define the term thermal engineering.

Ans: Thermal engineering is the science that deals with the energy transfer to practical applications such as energy transfer power generation, refrigeration, gas compression and its effect on the properties of working substance.

2. What is meant by thermodynamic system? How do you classify it?

Ans: Thermodynamic system is defined as the any space or matter or group of matter where the energy transfer or energy conversions are studied.

It may be classified into three types. 1. Open system, 2. Closed system and 3. Isolated system

3. What is meant by closed system? Give an example.

Ans: When a system has only heat and work transfer, but there is no mass transfer, it is called as closed system.

Example: Piston and cylinder arrangement.

4. Define a open system, Give an example.

Ans: When a system has both mass and energy transfer it is called as open system.

Example: Air Compressor.

5. Differentiate closed and open system.

Closed System	Open System
1. There is no mass transfer. Only	1. Mass transfer will take place, in addition

1909514 - THERMAL ENGINEERING LABORATORY

heat and work will transfer.	to the heat and work transfer.
2. System boundary is fixed one	2. System boundary may or may not change.
3. Piston & cylinder arrangement, Thermal power plant	3. Air compressor, boiler

6. Define an isolated system

Ans: Isolated system is not affected by surroundings. There is no heat, work and mass transfer take place. In this system total energy remains constant. Example: Entire Universe

7. Define: Specific heat capacity at constant pressure.

Ans: It is defined as the amount of heat energy required to raise or lower the temperature of unit mass of the substance through one degree when the pressure kept constant. It is denoted by C_p .

8. Define: Specific heat capacity at constant volume.

Ans: it is defined as the amount of heat energy required to raise or lower the temperature of unit mass of the substance through one degree when volume kept constant.

9. What is meant by surroundings?

Ans: Any other matter outside the system boundary is called as surroundings.

10. What is boundary?

Ans: System and surroundings are separated by an imaginary line is called boundary.

VIVA QUESTIONS WITH OUT ANSWERS

1. What is the difference between valves and ports?
2. How does the opening and closing of ports happen in two stroke engines?
3. What is the use of transfer port?
4. Give reason for larger exhaust port diameter than the transfer port.
5. What do you mean by scavenging?
6. What is the pressure developed in crank case?
7. What are the problems associated with two stroke engines?
8. What are the advantages of two stroke engines?
9. How are two stroke engines lubricated? Give the name.
10. Define compression ratio. Give the range of compression ratio for petrol and diesel engines.

1909514 - THERMAL ENGINEERING LABORATORY

EXP.NO:

DATE:

PORT TIMING DIAGRAM FOR A TWO STROKE PETROL ENGINE

Aim:

To study the cut section of a given two stroke variable speed engine and to draw the timing diagram.

THEORY:

The working cycle of the engine is completed in two strokes of the piston or in one revolution of crank shaft. During the upward stroke, the suction and compression process take place and during the down ward stroke the expansion and exhaust process take place. It has no valves but consists of an inlet port, exhaust port and transfer port.

Here the burnt gases are forced out through the exhaust port by a fresh charge of the fuel which enters the cylinder nearly at the end of working stroke through the transfer port. This process is termed as **SCAVENGING**. The top of the piston is made up of particular shape that facilitates the deflection of the fresh charge up wards and thus avoids the escape along with exhaust gases.

DESCRIPTION:

During the upward stroke of the piston the inlet port (IP) opens and fresh charge (air- fuel mixture) enters the crank case due to the suction created the charge already drawn from the inlet port in the previous stroke is get compressed and the ignition starts due to the spark given by the spark plug. Due to the expansion, gas is doing some work on the piston, so the piston is pushed down. During this down ward stroke the exhaust port (EP) opens and the product of combustion leaves from the cylinder. Also the piston compresses the mixture stored in the crank shaft, which will be supplied to the cylinder through transfer port (TP). This pushes out the burnt gases out of the exhaust port. The top of the piston is made of particular shape (Concave) that facilitates the deflection of the fresh charge and thus avoids the escape along with exhaust gases. After reaching the bottom dead center, when the piston moves up it first closes the transfer port (TP) and then the exhaust port. The fresh charge gets compressed and then ignition starts by means of spark plug. After the ignition of the charge, the piston moves down wards for the power stroke and the cycle is repeated as before.

SPECIFICATION:

Engine Type: Two Stroke Variable Speed Single Cylinder Vertical Petrol Engine.

1909514 - THERMAL ENGINEERING LABORATORY

Ignition: Magnetic Type.

Instruments Required: Measuring tape & A strip of paper

PROCEDURE:

1. Find out the direction of the fly wheel.
2. Identify the ports.
3. Mark the reference point on the fly wheel.
4. Mark the TDC and BDC position on the fly wheel.
5. Find out the opening and the closing point of inlet, exhaust and transfer ports are marked on the fly wheel.
6. Measure the circumference of the fly wheel by using a tape or thread.
7. Find out the arc length of the IPO, IPC, EPO, EPC, TPO & TPC with respect to TDC and BDC which is close to those points.

FORMULA USED:

$$\text{Angle} = \frac{360 * X}{L}$$

Where,

X = Arc Length in cm

L = Circumference of the flywheel in cm ($2\pi r$)

TABULATION:

Sl.No.	Events	Before/After TDC/BDC	Arc Length (cm)				Angle (θ) Degree
			A cm	B cm	C cm	Average = (a+b+c)/3	
1.	IPO						
2.	IPC						
3.	TPO						
4.	TPC						
5.	EPO						
6.	EPC						

Result:

The actual cut section and operation of the two stroke petrol engine has been carried out and port timing diagram is drawn.

1909514 - THERMAL ENGINEERING LABORATORY

VIVA QUESTIONS AND ANSWERS

1. What is meant by thermodynamic property?

Ans: Thermodynamic property is any characteristic of a substance which is used to identify the state of the system and can be measured, when the system remains in an equilibrium state.

2. How do you classify the property?

Ans: Thermodynamic property can be classified into two types.

1. Intensive or Intrinsic and
2. Extensive and Extrinsic property.

3. Define Intensive and Extensive properties.

Ans: The properties which are independent on the mass of the system is called intensive properties.

The properties which are dependent on the mass of the system is called extensive properties.

4. Differentiate Intensive and Extensive properties

Dependent on mass and without mass dependent

5. What do you understand by equilibrium of a system?

Ans: When a system remains in equilibrium state, it should not undergo any changes to its own accord.

6. What is meant by thermodynamic equilibrium?

Ans: When a system is in thermodynamic equilibrium, it should satisfy the following three conditions.

Mechanical Equilibrium, Thermal equilibrium, Chemical equilibrium

7. State the First law of thermodynamics

Ans: First of thermodynamics states that when system undergoes a cyclic process the net heat transfer is equal to work transfer.

8. Define: PMM of first kind

Ans: PMM of first kind delivers work continuously without any input. It violates first law of thermodynamics, It is impossible to construct an engine working with this principle.

9. Define the term process

Ans: It is defined as the change of state undergone by a gas due to energy flow.

10. Define the term Cycle: Ans: When a system undergoes a series of processes and return to its initial condition, it is known as cycle.

VIVA QUESTIONS WITH OUT ANSWERS

1. How the valves are different from ports?
2. What are the advantages of four stroke engines over two stroke engines?
3. Why four stroke engines are more fuel efficient than two stroke engines?
4. Explain the lubrication system of four stroke engines.
5. What do you mean by valve overlap? What are their effects in SI engines?
6. How the cylinder numbers assigned in multi-cylinder I.C. engines?
7. Give firing order for a four and six cylinder engines.
8. Explain how the correct direction of rotation is found before starting the valve timing experiment.
9. How do you identify an engine is working on two stroke or four stroke principle?
10. How do you identify whether it is petrol or diesel engine?

1909514 - THERMAL ENGINEERING LABORATORY

Exp. No:

Date:

PERFORMANCE TEST ON 4 STROKE DIESEL ENGINE WITH MECHANICAL LOADING

AIM:

To conduct a load test on four stroke diesel engine and to calculate the various efficiencies.

APPARATUS REQUIRED:

Four stroke diesel engine with mechanical loading arrangement

ENGINE SPECIFICATION:

Engine	:	Kirloskar make, 4 stroke, single cylinder, vertical, water cooled, hand cranking type diesel engine
Engine bore	:	80 mm
Stroke	:	110 mm
Engine power	:	5 HP, 1500rpm, governor controlled.
Loading	:	Brake drum of 400mm diameter with spring balance & belt brake.
Fuel measuring	:	Burette with 3-way cock.

PROCEDURE:

1. Crank the engine to hear the fuel injection creek sound and put the decompression lever down and the engine starts. Care to be taken to remove the handle immediately on starting the engine.
2. Start the engine at no load condition and allow it to stabilize.
3. Note down the speed, fuel consumed, spring balance and manometer readings at no load condition.
4. Add weight on loading pan and allow the engine to stabilize.
5. Note down all the readings again.
6. Repeat the experiment for various loads.
7. It is preferred to take readings in the ascending order of loads.

CALCULATION:

1. Brake power (BP)

$$BP = \frac{2\pi NT}{60} W$$

Where T = Torque = (W-S) X 9.81 X R in N

N - Speed of the engine in rpm

1909514 - THERMAL ENGINEERING LABORATORY

R - Radius of the Brake drum = $(D + 2d)/2$ in m

2. Total fuel consumption (TFC)

$$TFC = \frac{10 \times 0.8 \times 3600}{t \times 1000} \text{ Kg/hr}$$

Where "t" is the time for 10cc fuel from burette in seconds

3. Specific fuel consumption (SFC)

$$SFC = \frac{TFC}{BP} \text{ Kg/KW hr}$$

4. Willions line: The BP Vs TFC curve is drawn and produced to meet the negative BP axis which gives friction power FP.
5. Indicted power IP = BP + FP in KW
6. Brake thermal efficiency (η_{BT})

$$= \frac{BP \times 3600}{TFC \times C_v} \times 100 \text{ in } \%$$

7. Mechanical efficiency (η_{mech})

$$= BP/IP \times 100\%$$

8. Indicated efficiency (η_{IT})

$$= \frac{IP \times 3600}{TFC \times C_v} \times 100 \text{ in } \%$$

9. Volumetric Efficiency (η_v):

$$\text{Volumetric efficiency} = \frac{V_{actual}}{V_{theoretical}}$$

$$V_{theoretical} = \frac{LAN}{60}$$

L = Stroke length

A = Area of the piston, knowing the bore diameter the area may be calculated.

N = Speed in rpm.

$$V_{act} = a * \sqrt{2 \times g \times h_a} \quad \frac{m^3}{s}$$

where a - area of the orifice in m^2

1909514 - THERMAL ENGINEERING LABORATORY

$$h_a = \frac{\frac{\rho_w}{\rho_a}}{(h_1 - h_2)} \text{ in } m$$

where ρ_w - Density of water (1000 Kg/m³)

ρ_a - Density of air (1.16 Kg/m³)

h_1 & h_2 - Manometer readings

GRAPHS:

BP V_s TFC

BP V_s SFC

BP V_s B.Th. efficiency, I.T Efficiency & Volumetric Efficiency.

TABULATION - 1:

S. No	Load (in kg)		Time taken for 10cc fuel consumption	Speed (rpm)	Manometer readings in cm	
	W	S			h1	h2

TABULATION - 2:

S.No	BP (KW)	TFC (Kg/hr)	SFC (Kg/KW hr)	FP (KW)	IP (KW)	η_{mech} in %	η_{BT} in %	η_{IT} in %	η_v in %

RESULT:

Thus the performance test on four stroke single cylinder diesel engine is conducted and the performance curves are drawn.

1909514 - THERMAL ENGINEERING LABORATORY

VIVA QUESTIONS AND ANSWERS

1. What is meant by open and closed cycle.

Ans: In a closed cycle, the same working substance will recirculate again and again. In an open cycle, the same working substance will be exhausted to the surroundings after expansion.

2. What is meant by reversible and irreversible process.

Ans: A process is said to be reversible, it should trace the same path in the reverse direction when the process is reversed.

3. What is meant by Point and Path function?

Ans: The quantities which are independent on the process or path followed by the system are known as point functions. Example: Pressure, volume, temperature, etc.,

The quantities which are dependent on the process or path followed by the system are known as path functions. Example: Heat transfer, work transfer.

4. What is Quasi – Static process?

Ans: The process is said to be quasi – static, it should proceed infinitesimally slow and follows a continuous series of equilibrium states.

5. Explain Zeroth Law of thermodynamics?

Ans: Zeroth law of thermodynamics states that when two systems are separately in thermal equilibrium with a third system, then they themselves are in thermal equilibrium with each other.

6. Define the term enthalpy?

Ans: The combination of internal energy and flow energy is known as enthalpy of the system. It may also be defined as the total heat of the substance.

7. Define the term internal energy

Ans: Internal energy of a gas is the energy stored in a gas due to its molecular interactions.

It is also defined as the energy possessed by a gas at a given temperature.

8. What is meant by thermodynamic work?

Ans: It is the work done by the system when the energy is transferred across the boundary of the system.

It is mainly due to intensive property difference between the system and surroundings.

9. Define Heat.

Ans: Heat is the energy crossing the boundary due to the temperature difference between the system and surroundings.

10. Give the general gas energy equations. Ans: $dH = dE + dW$.

VIVA QUESTIONS WITH OUT ANSWERS

1. What is volumetric efficiency?
2. What is air fuel ratio in two stroke single cylinder petrol engine?
3. What is air delivery ratio in two stroke single cylinder petrol engine?
4. What is tapping efficiency?
5. Define pressure loss coefficient?
6. Define excess Air factor?
7. What is fan dynamometer?
8. Explain an automatic fuel flow meter?
9. Explain the method of measurement of smoke by comparison method?
10. Define the friction power?

1909514 - THERMAL ENGINEERING LABORATORY

EXP. NO.:

DATE:

ACTUAL P - V DIAGRAMS OF A FOUR – STROKE DIESEL ENGINE WITH ELECTRICAL LOADING

AIM

To conduct a load test on four stroke diesel engine and draw the actual p-V diagram of Compression Ignition Engine using Data Acquisition Interface.

APPARATUS REQUIRED

Four Stroke Diesel Engine with Electrical Loading, Data Acquisition System with Computer and accessories.

ENGINE SPECIFICATION:

Engine	:	Kirloskar make, 4 stroke, single cylinder, vertical, water cooled, hand cranking type diesel engine
Engine bore	:	80 mm
Stroke	:	110 mm
Engine power	:	5 HP, 1500rpm, governor controlled.
Loading	:	Electrical Resistance Loading with maximum of 3.5 KW.
Fuel measuring	:	Burette with 3-way cock.

PROCEDURE:

1. Crank the engine to hear the fuel injection creek sound and put the decompression lever down and the engine starts. Care to be taken to remove the handle immediately on starting the engine.
2. Start the engine at no load condition and allow it to stabilize.
3. Note down the speed, fuel consumed, spring balance and manometer readings at no load condition.
4. Increase electrical load to the alternator and allow the engine to stabilize.
5. For each loading, the operating parameters of the Engine are automatically recorded with the help of computerized Data Acquisition interface and performance curves are drawn.
7. It is preferred to take readings in the ascending order of loads.

CALCULATION:

1. Brake power (BP)

$$BP = (V \times I)$$

Where V in Voltage and I in Amperes

1909514 - THERMAL ENGINEERING LABORATORY

2. Total fuel consumption (TFC)

$$TFC = \frac{10 \times 0.8 \times 3600}{t \times 1000} \text{ Kg/hr}$$

Where “t” is the time for 10cc fuel from burette in seconds

3. Specific fuel consumption (SFC)

$$SFC = \frac{TFC}{BP} \text{ Kg/KW hr}$$

4. Willions line: The BP Vs TFC curve is drawn and produced to meet the negative BP axis which gives friction power FP.
5. Indicted power IP = BP + FP in KW
6. Brake thermal efficiency (η_{BT})

$$= \frac{BP \times 3600}{TFC \times C_v} \times 100 \text{ in } \%$$

7. Mechanical efficiency (η_{mech})

$$= BP/IP \times 100\%$$

8. Indicated efficiency (η_{IT})

$$= \frac{IP \times 3600}{TFC \times C_v} \times 100 \text{ in } \%$$

9. Volumetric Efficiency (η_v):

$$\text{Volumetric efficiency} = V_{\text{actual}} / V_{\text{theoretical}}$$

$$V_{\text{theoretical}} = \frac{LAN}{60}$$

L = Stroke length

A = Area of the piston, knowing the bore diameter the area may be calculated.

N = Speed in rpm.

$$V_{\text{act}} = a * \sqrt{2 \times g \times h_a} \quad \frac{m^3}{s}$$

where a - area of the orifice in m^2

1909514 - THERMAL ENGINEERING LABORATORY

$$h_a = \frac{\frac{\rho_w}{\rho_a}}{(h_1 - h_2)} \text{ in } m$$

where ρ_w - Density of water (1000 Kg/m³)

ρ_a - Density of air (1.16 Kg/m³)

h_1 & h_2 - Manometer readings

GRAPHS:

Using computerized Data Acquisition interface, p - θ and p-V diagrams are drawn.

TABULATION - 1:

S. No	Load		Time taken for 10cc fuel consumption (t) in sec	Speed (rpm)	Manometer readings in cm	
	V in Volts	I in Amperes			h ₁	h ₂

TABULATION - 2:

S.No	BP (KW)	TFC (Kg/hr)	SFC (Kg/KW hr)	FP (KW)	IP (KW)	η_{mech} in %	η_{BT} in %	η_{IT} in %	η_v in %

VIVA QUESTIONS & ANSWERS

1. In otto cycle the compression ratio is _____ to expansion ratio. Ans: Equal

2. In diesel engine, the compression ratio is _____ than expansion ratio? Ans: Greater

3. What is meant by cutoff ratio?

Ans: Cutoff ratio is defined as the ratio of volume after the heat addition to before the heat addition. It is denoted by the letter 'p'

4. What are the assumptions made for air standard cycle.

Ans: 1. Air is the working substance, 2. Throughout the cycle, air behaves as a perfect gas and obeys all the gas laws,

5. What is the difference between otto and Diesel cycle.

Otto is for petrol engine and diesel cycle for diesel engines

6. What is the other name given to otto cycle?

Ans: Constant volume cycle.

7. What is meant by air standard efficiency of the cycle?

Ans: It is defined as the ratio of work done by the cycle to the heat supplied to the cycle.

8. Define: Mean effective pressure of an I.C. engine.

Ans: Mean effective pressure is defined as the constant pressure acting on the piston during the working stroke. It is also defined as the ratio of work done to the stroke volume or piston displacement volume.

9. What will be the effect of compression ratio on efficiency of the diesel cycle?

Ans: Efficiency increases with the increase in compression ratio and vice – versa.

10. What will be the effect of cut off ratio on efficiency of the diesel cycle.

Ans: Efficiency decreases with the increase of cut off ratio and vice – versa.

VIVA QUESTIONS WITH OUT ANSWERS

1. What is break power ?
2. Define speed performance test on a four-stroke single – Cylinder diesel engine?
3. What is Air rate and A/F ratio in a four-stroke single – Cylinder diesel engine?
4. What is combustion phenomenon?
5. What is indicated power ?
6. Mention the simplified various assumptions used in fuel Air-cycle Analysis
7. Explain the significance of the fuel-Air cycle ?
8. What is the difference between Air – Standard cycle & Fuel – Air cycle analysis?
9. Define carburetion?
10. What are the different Air – Fuel Mixture on which an Engine can be operated?

1909514 - THERMAL ENGINEERING LABORATORY

EXP. NO.:

DATE:

HEAT BALANCE TEST ON A FOUR – STROKE DIESEL ENGINE

AIM

To conduct performance test on 4-Stroke diesel engine(Single cylinder) and to check the heat balance of I.C engine.

APPARATUS / EQUIPMENTS / INSTRUMENTS REQUIRED

High speed vertical diesel engine test rig., Measuring tape, Stop watch, Tachometer, Thermometer, Dead weights and one litre jar.

ENGINE DETAILS

Type	:	Vertical
Bore	:	87.5 mm
Stroke	:	110 mm
Cooling	:	air cooling
Rated power	:	5HP (3.8 KW)
Rated speed	:	1500 rpm
Type of loading	:	Rope Brake Dynamometer.

FUEL SPECIFICATION:

Fuel	:	High Speed Diesel (hsd)
C.V	:	46,000 KJ/kg
Density	:	0.86 g/cc

OBSERVATIONS

1. Specific heat of Exh. gas $C_p = 1.005$ KJ/kg k.
2. Room temperature $T_1 =$ °C

MAX LOAD CALCULATION (W_{MAX})

Circumference of the brake drum (D)= m

Circumference of the rope (d) = m

$$R = \frac{(D+d)}{2}$$

$$W_{max} = \frac{BP \times 60 \times 1000}{2\pi NR}$$

PRECAUTION

1. The engine should not be started or stopped under load.

1909514 - THERMAL ENGINEERING LABORATORY

2. The lubricating level should be ensured.
3. The engine cooling water supply should be ensured (if it is a water cooled engine).

PROCEDURE

1. First the rated speed of the engine is calculated.
2. The engine is started under no – load by hand cranking and the speed is adjusted to the rated value.
3. It is run under no – load condition for a few minutes so that the speed stabilizes at the rated value.
4. The time taken for 10 cc of fuel consumption (t) is noted using the stop watch for on load condition.
5. The difference in water column in the manometer is noted .
6. The time taken for 1 lit of cooling water flow from the engine (t₁) is noted down.
7. The inlet and outlet temperature of the cooling water from the engine (T₂ & T₃) are noted from the digital temperature indicator.
8. The exhaust gas temperature before and after calorimeter (T₄ & T₅) are noted from the digital temperature indicator.
9. The outlet temperature of the cooling water from the calorimeter (T₆) is noted from the digital temperature indicator.
10. Now the engine is loaded to one fourth the rated load and all the above observations are recorded under steady state condition.
11. Similarly the above procedure is followed for various load conditions
12. The loads are removed gradually and the engine is stopped.

FORMULAE:

1. Head Supplied (Q_{sup}):

Input Power = Total Fuel Consumption X Caloric value of fuel

$$Q_{\text{sup}} = \left(\frac{9.81}{t} * \frac{0.83}{1000} * 3600 \right) * C_v \text{ (KJ/hr)}$$

where

t – time taken to consume 10 cc fuel in sec

C_v – Calorific value of fuel (46,150 KJ/Kg)

2. Useful output = Brake Power (Q_{BP})

$$BP = \frac{2\pi NT}{(60 \cdot 1000)} \text{ in KW}$$

where

N – speed of the engine in rpm

1909514 - THERMAL ENGINEERING LABORATORY

$$T - \text{Torque} = (W-S) * g * R \text{ in Nm}$$

where W – Load in Kg, S – Spring balance reading

R – Radius of the brake drum in m

3. Mass of cooling water (m_c):

$$m_c = \frac{3600}{t} \text{ in Kg/hr}$$

where

t - time taken to collect 1 litre of water

4. Head across orifice (H_a):

$$H_a = \left(H_w * \frac{\rho_w}{\rho_a} \right) \text{ m of air}$$

Where $H_m - (h_1 - h_2)$ in meter, ρ_w - Density of water in Kg/m^3

ρ_a - Density of air in $(1.24) \text{ Kg/m}^3$

5. Mass of air (m_a):

$$m_a = \rho_a * C_d * A * \sqrt{2gH_a} \text{ Kg/hr}$$

6. Mass of exhaust gas (m_g):

$$m_g = m_a * \text{TFC Kg/hr}$$

7. Total Quantity of heat energy input (Q_1):

$$Q_1 = \text{TFC} * \text{CV KJ/hr}$$

8. Quantity of heat energy converted in to Useful output (Brake Power Q_{BP}):

$$Q_{BP} = \text{BP} * 3600 \text{ KJ/hr}$$

9. Percentage of heat utilized:

$$\frac{Q_{BP}}{Q_1} * 100 \text{ in } \%$$

NOTE: Substitute Brake Power in KJ/hr

10. Heat absorbed by the cooling water (Q_w)

$$Q_w = m_c C_{pc} (T_3 - T_2) \text{ in KJ/hr}$$

11. Percentage of heat absorbed by the cooling water:

$$= \left(\frac{Q_c}{Q_1} * 100 \right) \text{ in } \%$$

12. Heat absorbed by the Exhaust gases (Q_g)

$$Q_g = m_g C_{pg} (T_5 - T_4) \text{ in KJ/hr}$$

1909514 - THERMAL ENGINEERING LABORATORY

13. Percentage of heat absorbed by the Exhaust gases:

$$= \left(\frac{Q_g}{Q_t} * 100 \right) \text{ in } \%$$

where

m_g – mass of exhaust gases in Kg/hr

C_{peg} - Specific heat capacity of exhaust gas (1.005 KJ/Kg C)

T_4 – Exhaust gas temperature before calorimeter in °C

T_5 – Exhaust gas temperature after calorimeter in °C

14. Unaccounted heat losses (Q_{un}):

$$Q_{un} = Q_{sup} - (Q_{BP} + Q_w + Q_g)$$

15. Percentage of unaccounted heat loss:

$$= \left(\frac{Q_{un}}{Heat\ supplied} * 100 \right) \text{ in } \%$$

1909514 - THERMAL ENGINEERING LABORATORY

<u>Sl. No</u> :	<u>Load in Kg</u>		<u>(W-S)</u> <u>x 9.81</u> <u>N</u>	<u>Time taken for 10 cm fuel consumption</u>	<u>Speed in rpm</u>	<u>Temperature Reading in °C</u>						<u>Time taken to collect 1 litre of water from the engine in sec</u>	<u>Time taken to collect 1 litre of water from the calorimeter in sec</u>	<u>Manometer Depression</u> $H_w = \frac{(H_1 - H_2)}{C_m}$
	<u>W</u>	<u>S</u>				<u>T₁</u>	<u>T₂</u>	<u>T₃</u>	<u>T₄</u>	<u>T₅</u>	<u>T₆</u>			

1909514 - THERMAL ENGINEERING LABORATORY

TABULAR COLUMN: HEAT BALANCE SHEET

<u>S</u> <u>L</u> <u>N</u> <u>O</u>	<u>B</u> <u>P</u>	<u>H</u> <u>a</u>	<u>TF</u> <u>C</u>	<u>m_c</u>	<u>m_a</u>	<u>m_g</u>	<u>Q_I</u>	<u>Q_B</u> <u>P</u>	<u>%</u> <u>Q</u> <u>BP</u>	<u>Q_c</u>	<u>%</u> <u>Q</u> <u>c</u>	<u>Q_g</u>	<u>%</u> <u>Q</u> <u>g</u>	<u>Q_u</u>	<u>%</u> <u>Q</u> <u>u</u>	<u>TO</u> <u>TAL</u>
	<u>K</u> <u>W</u>	<u>m</u>	<u>Kg</u> <u>/hr</u>	<u>Kg</u> <u>/hr</u>	<u>Kg</u> <u>/hr</u>	<u>Kg</u> <u>/hr</u>	<u>KJ</u> <u>/hr</u>	<u>KJ</u> <u>/hr</u>	<u>%</u>	<u>KJ</u> <u>/hr</u>	<u>%</u>	<u>KJ</u> <u>/hr</u>	<u>%</u>	<u>KJ</u> <u>/hr</u>	<u>%</u>	<u>%</u>

RESULT:

Thus the heat balance sheet of a four stroke diesel engine is prepared and verified.

1909514 - THERMAL ENGINEERING LABORATORY

VIVA QUESTIONS AND ANSWERS

1. State the law of conservation of energy

Ans: Energy can neither be created nor destroyed, but it can be transferred from one form to another.

2. Define entropy of a pure substance.

Ans: Entropy is an important thermodynamic property, which increases with addition of heat and decreases with its removal. Entropy is a function of temperature only. It is an unavailability of energy during energy transfer.

3. Define an isentropic process.

Ans: Isentropic process is also called as reversible adiabatic process. It is a process which follows the law of $pV^\gamma = C$ is known as isentropic process. During this process entropy remains constant and no heat enters or leaves the gas.

4. Explain the throttling process.

Ans: When a gas or vapour expands and flows through an aperture of small size, the process is called as throttling process.

5. Work done in a free expansion process is _____ Ans: Zero

6. Define free expansion process.

Ans: When a gas expands suddenly into a vacuum through a large orifice is known as free expansion process.

7. Which property is constant during throttling? Ans: Enthalpy

8. If in the equation $PV^n = C$, the value of $n =$ then the process is called _____

Ans: Constant Volume process

9. The polytropic index (n) is given by _____ Ans: $n = \log (P_2/P_1) / \log (V_1/V_2)$

10. Work transfer is equal to heat transfer in case of _____ process. Ans: Isothermal process.

VIVA QUESTIONS WITH OUT ANSWERS

1. What is the significance of heat balance sheet?
2. How does useful work differ from actual work? For what kind of systems are these two identical?
3. What are unaccounted losses?
4. Name four physical quantities that are conserved and two quantities that are not conserved during a process
5. Express mathematically energy balance of control volume.
6. What is the second-law efficiency? How does it differ from the first-law efficiency?
7. Can a system have a higher second-law efficiency than the first-law efficiency during a process? Give examples.
8. What are the different mechanisms for transferring energy to or from a control volume?
9. What is flow energy? Do fluids at rest possess any flow energy?
10. What are different efficiencies associated with IC engines?

1909514 - THERMAL ENGINEERING LABORATORY

EXP. NO.:

DATE:

MORSE TEST ON MULTICYLINDER PETROL ENGINE.

AIM:

A rapid and adequate measurement of indicated powers multi – cylinders Can be obtained by performing the Morse test which required no special instrumentation.

SPECIFICATION :

Manufacturer : Ambassador

Rate Power : 50 HP

Type Of Dynamometer : Hydraulic Dynamometer

PRECAUTIONS:

1. Check for the coolant supply and coolant rate.
2. Check for lube oil level in the engine crankcase.
3. Check the fuel level in the fuel tank.
4. Make sure that no load is acting on the dynamometer when the engine is started.
5. Supply the dynamometer coolant while loading the engine.

PROCEDURE:

1. Start the engine at no load conditions, maintaining part load in the dynamometer slowly
2. release the clutch lever and adjust the throttle valve for one particular speed and note down it .
3. Coincide the reference point with the pointer in the dynamometer and note down the Corresponding load from the load gauge.
4. Short circuit the first plug and releases it in the order to maintain same constant speed.
5. Coincide the reference point with the pointer in the dynamometer and note down the Corresponding load from the load gauge.
6. Now engage the first plug and short circuit the second one.
7. If there is any variation in the speed adjust the load accordingly to maintain the Same speed.
8. Coincide the reference point with the pointer in the dynamometer and note down the Corresponding load from the load gauge.
9. Similarly repeat the procedure for the third and fourth plug.
10. The readings are tabulated.
11. Using the available empirical relations the IP , FP and Mechanical Efficiency of the engine is calculated .

1909514 - THERMAL ENGINEERING LABORATORY

TABULATION:

Sl.No.	Cylinder Condition	Engine speed in RPM	Load W in Kg	Brake Power (BP)	Indicated Power (IP)
1	All cylinders are firing			BP =	IP =
2	First cylinder is cut-off			BP1 =	IP1 =
3	Second cylinder is cut-off			BP2 =	IP2 =
4	Third cylinder is cut-off			BP3 =	IP3 =
5	Fourth cylinder is cut-off			BP4 =	IP4 =

CALCULATIONS:

1. Total Brake Power (BP), when all Cylinders are firing.

$$BP = \frac{2\pi NT}{4500} \text{ HP}$$

where N - speed in rpm

T = Torque = Brake Drum Radius X (W₁ - W₂) X g in N

2. Brake Power (BP1), when first Cylinder is cut-off.

$$BP1 = \frac{2\pi NT_1}{4500} \text{ HP}$$

T₁ = Torque = Brake Drum Radius X (W₁ - W₂) X g in N

where T₁ - Torque when first Cylinder is cut-off

3. Brake Power (BP2), when second Cylinder is cut-off.

$$BP2 = \frac{2\pi NT_2}{4500} \text{ HP}$$

T₂ = Torque = Brake Drum Radius X (W₁ - W₂) X g in N

where T₂ - Torque when second Cylinder is cut-off

4. Brake Power (BP3), when third Cylinder is cut-off.

$$BP3 = \frac{2\pi NT_3}{4500} \text{ HP}$$

1909514 - THERMAL ENGINEERING LABORATORY

$$T_3 = \text{Torque} = \text{Brake Drum Radius} \times (W_1 - W_2) \times g \text{ in N}$$

where T_3 - Torque when third Cylinder is cut-off

5. Brake Power (BP4), when fourth Cylinder is cut-off.

$$BP4 = \frac{2\pi NT_4}{4500} \text{ HP}$$

$$T_4 = \text{Torque} = \text{Brake Drum Radius} \times (W_1 - W_2) \times g \text{ in N}$$

where T_4 - Torque when fourth Cylinder is cut-off

6. Indicated Power (IP1), when first Cylinder is not firing.

$$IP1 = (BP) - (BP1)$$

7. Indicated Power (IP2), when second Cylinder is not firing.

$$IP2 = (BP) - (BP2)$$

8. Indicated Power (IP3), when third Cylinder is not firing.

$$IP3 = (BP) - (BP3)$$

9. Indicated Power (IP4), when fourth Cylinder is not firing.

$$IP4 = (BP) - (BP4)$$

10. Total Indicated Power

$$IP = IP1 + IP2 + IP3 + IP4$$

11. Total frictional power

$$FP = IP - BP$$

RESULT:

The total Indicated Power for the engine is _____.

The total Frictional Power for the engine is _____.

VIVA QUESTIONS AND ANSWERS

1. Write down the characteristic gas equation.

Ans: Characteristic gas equation is $pV = mRT$, Where p = pressure, V = Volume
 R = Characteristic gas constant & T = Temperature.

2. What is meant by steady flow process?

Ans: During the process the rate of flow of mass and energy across the boundary remains constant, is known as steady flow process.

3. What is the difference between steady flow and non – flow process?

Ans: During the steady flow process the rate of flow of mass and energy across the boundary remains constant. In case of non – flow across the system and boundary.

4. State the Kelvin – Plank statement of second law of thermodynamics

1909514 - THERMAL ENGINEERING LABORATORY

Ans: Kelvin – Plank states that it is impossible to construct a heat engine working on cyclic process, whose only purpose is to convert all the heat energy given to it into an equal amount of work.

5. State Clausius statement of second law of thermodynamics.

Ans: It states that heat can flow from hot body to cold without any external aid but heat cannot flow from cold body to hot body without any external aid.

6. State Carnot's theorem.

Ans: No heat engine operating in a cyclic process between two fixed temperature, can be more efficient than a reversible engine operating between the same temperature limits.

7. What are the Corollaries of Carnot theorem.

Ans: (i) In all the reversible engine operating between the two given thermal reservoirs with fixed temperature, have the same efficiency.

(ii) The efficiency of any reversible heat engine operating between two reservoirs is independent of the nature of the working fluid and depends only on the temperature of the reservoirs.

8. Define – PMM of second kind.

Ans: Perpetual motion machine of second kind draws heat continuously from single reservoir and converts it into equivalent amount of work. Thus it gives 100% efficiency.

9. What is the difference between a heat pump and a refrigerator?

Ans: Heat pump is a device which operating in cyclic process, maintains the temperature of a hot body at a temperature higher than the temperature of surroundings.

A refrigerator is a device which operating in a cyclic process, maintains the temperature of a cold body at a temperature lower than the temperature of the surroundings.

10. What is meant by heat engine?

Ans: A heat engine is a device which is used to convert the thermal energy into mechanical energy.

VIVA QUESTIONS WITH OUT ANSWERS

1. How to start and stop the CI engine?
2. What is the purpose of a decompression lever?
3. How the speed of the engine is maintained constant at all loads?
4. What is the function of a governor in a constant speed engine? Where it is normally located?
5. What is normal fuel injection pressure in a C I. engine?
6. What is the speed ratio between a cam shaft and a crank shaft?
7. What is the type of dynamometer employed?
8. Give reasons for valve timing greater than 180°?
9. What is the type of cooling employed?
10. How do you ensure the lubrication pump is effective?

1909514 - THERMAL ENGINEERING LABORATORY

EXP. NO.:

DATE:

RETARDATION TEST TO FIND FRICTIONAL POWER OF A DIESEL ENGINE.

AIM

The experiment is conducted to evaluate engine friction by conducting retardation test on single cylinder 4- stroke diesel engine.

APPARATUS REQUIRED:

Four stroke diesel engine with Hydraulic loading arrangement

TEST RIG SPECIFICATION:

Engine : Field marshal make.4 stroke Single cylinder ,vertical ,water cooled , hand cranking type diesel engine

Engine : Bore: 114.3 mm
: Stroke : 139.7 mm

Engine power : 6 H.P. & 650 rpm ,governor controlled.

Loading device : Hydraulic dynamometer.

Load indication : With a torque arm and a spring balance.
Length of torque arm = 420mm

Fuel measuring device : Burette with a 3-way cock.

Air intake measuring device : Air tank with a Orifice plate of 30 mm diameter and manometer

PROCEDURE:

1. Fill the fuel tank with diesel.
2. Open the 3 way cock; In this position the fuel flows from the tank to the engine filling the burette. To remove air block in the hose, remove the hose from the engine and hold it vertically up. Now connect the hose back to the engine and open the air bleed screw to allow the fuel to freely flow through the screw. Tighten the screw. Put the decompression lever up.
3. Crank the engine to hear the fuel injection creek sound and put the decompression lever down and the engine starts. Care to be take to remove the handle immediately on starting to the engine.
4. Allow required water for the Dynamometer. Adjust the load by adjusting the gate opening through the gear arrangement provided in front of the dynamometer.
5. The clockwise rotation of the handle will reduce the load. Slightly shake the dynamometer manually after adjusting the load to remove my friction in bearing & glands.

1909514 - THERMAL ENGINEERING LABORATORY

6. Note the spring balance reading.
7. Note the time for the fuel consumption from the burette by closing the 3 way cock for 10cc , fuel flow.
8. Note the manometer reading.
11. Repeat the procedure for other loads.
12. It is preferred to take readings in the ascending order of loads.
13. **For Retardation test:** Under no load condition suddenly cut the fuel supply by putting the fuel pump lever up, and simultaneously start the stop watch. The engine starts retarding and the rpm reduces. When the engine speed is 200 rpm below the initial value, stop the stop watch and note the time taken for retardation. Put the fuel pump lever down and the engine picks up speed and will run at the rated rpm. Keep around 50% load on the engine and follow the procedure as detailed above and note the retardation time for 200 rpm.

CALCULATION:

1. Brake power (BP)

$$BP = \frac{2\pi NT}{60} W$$

Where T = Torque = Torque arm length x Spring balance reading in N

N - Speed of the engine in rpm

2. Total fuel consumption (TFC)

$$TFC = \frac{10 \times 0.8 \times 3600}{t \times 1000} \text{ Kg/hr}$$

Where “t” is the time for 10cc fuel from burette in seconds

3. Specific fuel consumption (SFC)

$$SFC = \frac{TFC}{BP} \text{ Kg/KW/hr}$$

4. Frictional Power (Retardation test)

a). Load Torque on the arm (T_L) = W X R X 9.81 Nm

where W - Spring balance reading in N

R - Radius of the Brake drum in m

1909514 - THERMAL ENGINEERING LABORATORY

b). Frictional Load Torque (T_f)

$$T_f = T_L \left(\frac{T}{T_0 - T} \right)$$

where T = _____ time for retardation with 50% load.

T_0 = _____ time for retardation without load.

c). Frictional Power (FP)

$$FP = \frac{2\pi NT_f}{60 \times 1000} \text{ KW}$$

d). Indicated Power (IP)

$$IP = BP + FP \text{ in KW}$$

5. Brake thermal efficiency (η_{BT})

$$= \frac{BP \times 3600}{TFC \times Cv} \times 100 \text{ in \%}$$

6. Mechanical efficiency (η_{mech})

$$= BP/IP \times 100\%$$

7. Indicated efficiency (η_{IT})

$$= \frac{IP \times 3600}{TFC \times Cv} \times 100 \text{ in \%}$$

8. Volumetric Efficiency (η_{IT}):

$$\text{Volumetric efficiency} = \frac{V_{actual}}{V_{theoretical}}$$

$$V_{theoretical} = \frac{LAN}{60}$$

L = Stroke length

A = Area of the piston, knowing the bore diameter the area may be calculated.

N = Speed in rpm.

$$V_{act} = a * \sqrt{2 X g X h_a} \quad \frac{m^3}{s}$$

where a - area of the orifice in m^2

$$h_a = \frac{\frac{\rho_w}{\rho_a}}{(h_1 - h_2)} \text{ in } m$$

where ρ_w - Density of water (1000 Kg/m^3)

ρ_a - Density of air (1.16 Kg/m^3)

h_1 & h_2 - Manometer readings

Graphs:

1909514 - THERMAL ENGINEERING LABORATORY

BP V_s TFC

BP V_s SFC

BP V_s B.Th. efficiency, I.T Efficiency & Volumetric Efficiency.

TABULATION

Load W (Kg)	Time for 10cc fuel consumption (sec)	Manometer In cm		Retardation time 200 rpm
		h_1	h_2	

Brake Power in KW	TFC in Kg/hr	SFC in Kg/Kwh	Frictional Power in KW	Indicated Power in KW	B.Th. Efficiency in %	Mech. Efficiency in %	Indicated Efficiency in %	Volumetric Efficiency In %

VIVA QUESTIONS AND ANSWERS

1. Define the term COP?

Ans: Co-efficient of performance is defined as the ratio of heat extracted or rejected to work input.

$$\text{COP} = \frac{\text{Heat extracted or rejected}}{\text{Work input}}$$

2. Write the expression for COP of a heat pump and a refrigerator?

Ans: COP of heat pump

$$\text{COP}_{\text{HP}} = \frac{\text{Heat Supplied}}{\text{Work input}}$$

COP_{HP} =

3. What is the relation between COP_{HP} and COP_{ref} ?

Ans: $COP_{HP} = COP_{ref} + 1$

4. Why Carnot cycle cannot be realized in practical?

Ans: (i) In a Carnot cycle all the four process are reversible but in actual practice there is no process is reversible.

5. Name two alternative methods by which the efficiency of a Carnot cycle can be increased.

Ans: (i) Efficiency can be increased as the higher temperature T_2 increases. (ii) Efficiency can be increased as the lower temperature T_1 decreases.

6. Why a heat engine cannot have 100% efficiency?

Ans: For all the heat engines there will be a heat loss between system and surroundings. Therefore we can't convert all the heat input into useful work.

7. When will be the Carnot cycle efficiency is maximum?

Ans: Carnot cycle efficiency is maximum when the initial temperature is $0^\circ K$.

8. What are the processes involved in Carnot cycle.

Ans: Carnot cycle consist of i) Reversible isothermal compression, ii) isentropic compression, iii) reversible isothermal expansion and iv) isentropic expansion

9. Write the expression for efficiency of the carnot cycle.

$$\eta = 1 - T_2/T_1$$

10. Define: Thermodynamic cycles.

Ans: Thermodynamic cycle is defined as the series of processes performed on the system, so that the system attains to its original state.

VIVA QUESTIONS WITH OUT ANSWERS

1. When a car gets older will its compression ratio decrease? What about MEP?
2. What is the working principle of a tachometer?
3. What is indicated power?
4. What is brake power?
5. What is indicated mean effective pressure?
6. What is BMEP?
7. What is the relation between MEP and Swept volume?
8. What are different losses in IC engines?
9. How will you define mechanical efficiency of an engine define?
10. What is brake thermal efficiency?

1909514 - THERMAL ENGINEERING LABORATORY

EXP. NO.:

DATE:

DETERMINATION OF VISCOSITY – RED WOOD VISCOMETER

AIM

To determine the viscosity of given lubrication oil by Redwood Viscometer.

APPARATUS REQUIRED

1. Redwood Viscometer, 2. Thermometer, 3. Conical Flask and 4. Stop Watch

DESCRIPTION

Viscosity is the property of a fluid or liquid by virtue of which it offers resistance to its own flow. It is measured in poise. The kinematic viscosity of a liquid is a ratio of absolute viscosity to its density at the given temperature and the unit of kinematic viscosity is centistokes. Viscosity is the most important single property of any lubricating oil, because it is the main determinant of the operating characteristics of the lubricant. If the viscosity of the oil is too low, a liquid oil film cannot be maintained between two moving or sliding surfaces, and consequently excessive friction will result due to fluid friction.

Measurement of viscosity of lubricating oil is made with the help of an apparatus called the viscometer. In a viscometer, a fixed volume of the liquid is allowed to flow from a given height through a standard capillary tube under its own weight and the time of flow in seconds is noted. The time is proportional to true viscosity.

Redwood viscometer is of two types: Redwood viscometer No.1 is commonly used for determining viscosities of thin lubricating oils and it has a jet of bore diameter 1.62 mm and length 10 mm. Redwood viscometer No.2 is used for measuring viscosities of highly viscous oils. It has a jet of diameter 3.8 mm and length 15 mm.

FORMULA:

1. Density (ρ)

$$= \rho [1 - \alpha(T - 15)] \text{ in } \frac{\text{Kg}}{\text{m}^3}$$

Where ρ – Density of the given oil (866 Kg/m³)

α – 0.00036 a constant

T – Temperature of oil

1909514 - THERMAL ENGINEERING LABORATORY

2. Kinematic Viscosity (ν)

$$= A * t - \left(\frac{B}{t} * 10^{-6} \right) \text{ in } \frac{\text{m}^2}{\text{s}}$$

Where

A = 0.247, B = 65, for t = 85 to 200 seconds.

T – Time taken to collect 50 ml in seconds.

A = 0.264, B = 190, for t = 40 to 85 seconds.

3. Dynamics Viscosity (μ)

$$= (\rho * \nu) \text{ in } \frac{\text{Ns}}{\text{m}^2}$$

PROCEDURE:

1. The leveled oil cup is cleaned and ball valve rod is placed on the gate jet to close it.
2. Oil under test, free from any suspension and is filled in the cup up to the pointer level.
3. An empty conical flask is kept just below the jet.
4. Water is filled in the bath and side tube is heated slowly with constant stirring of the bath.
5. When the oil is at the desired temperature, the ball valve is lifted and suspended from thermometer bracket.
6. The time taken to collect 50 ml of oil in the flask is noted and the valve is immediately closed to prevent any overflow of oil.
7. Similarly the above procedure is repeated for the oil at various temperatures and the viscosity is calculated.
8. Plot a graph between the temperature and the viscosity of oil.

TABULAR COLUMN:

Sl. No.	Temperature oil in °C	Time taken for 50 ml oil collection in seconds	Density (ρ) in Kg/ m ³	Kinematic Viscosity (ν) in m ² /s	Dynamic Viscosity (μ) in Ns/m ²

DIAGRAM:

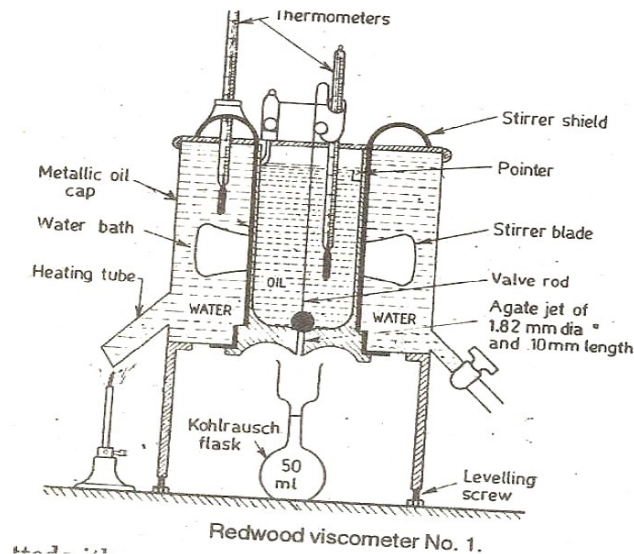

GRAPH:

1. Temperature V_s Kinematic Viscosity.
2. Temperature V_s Dynamic Viscosity.

RESULT:

Thus the Viscosity of the lubricating oil is found out using Redwood Viscometer and the graphs are drawn.

VIVA QUESTIONS AND ANSWERS

1. What is known as viscosity?

The property of a fluid which offers resistance to the movement of one layer of fluid over adjacent layers of fluids is called viscosity.

2. What is meant by kinematic viscosity?

The ratio between the dynamic viscosity and density is defined as kinematic viscosity of a fluid.

3. State 'Newton's law of viscosity.'

It states that 'For a steady uniform flow, the shear stress on a fluid element is layer is directly proportional to the rate of shear strain. The constant of proportionality is called the coefficient of viscosity.

4. Define density or mass density?

Density of a fluid is defined as the ratio of the mass of a fluid to its volume. Its unit is Kg/m³.

5. Define specific gravity or relative density?

Specific gravity is defined as the ratio of the weight density of a fluid to the weight density of a standard of a standard fluid.. for liquids, the standard fluid is taken as water and for gases , the standard fluid is taken as air.

6. Define specific volume?

Specific volume of a fluid is defined as the volume of a fluid occupied by a unit mass or volume per unit mass of a fluid. It is expressed as m^3 / Kg .

7. Define specific weight or weight density?

Specific weight or weight density of a fluid is defined as the ratio between the weight of a fluid to its volume. It is denoted by ω . $\omega = \rho g$.

8. Define compressibility?

Compressibility is the reciprocal of bulk modulus of elasticity K , which is defined as the ratio of compressive to volumetric strain.

9. Define coefficient of compressibility?

Coefficient of compressibility is denoted by β and defined as volumetric strain per unit compressive stress.

10. Define surface tension of fluids?

The surface tension of a fluid is the property which enables the fluid to resist tensile stress. It is due to the cohesion between the molecules at the surface of a liquid.

VIVA QUESTIONS WITH OUT ANSWERS

1. What is turbulent viscosity?
2. What is meant by hydrodynamic boundary layer?
3. How is coefficient of viscosity defined?
4. What is dynamic viscosity?
5. What is the effect of temperature on viscosity on liquids? What about gases?
6. What is the difference between adhesive and cohesive force?
7. What is meant by no slip condition
8. What is meant by Newtonian fluids?
9. What is rheology?
10. What is the physical significance of Nusselt number

1909514 - THERMAL ENGINEERING LABORATORY

EXP. NO.:

DATE:

DETERMINATION OF FLASH POINT AND FIRE POINT OF VARIOUS FUELS / LUBRICANTS.

AIM:

To determine the flash and fire point of the given fuel/ Oil.

APPARATUS REQUIRED

1. Cleveland Open Cup apparatus.
2. Thermometer.

DESCRIPTION

Flash point is the lowest temperature at which the fuel gives off enough vapours that ignite for a moment, when a small flame is brought near to it. Fire point is the lowest temperature at which the vapours of the oil burn continuously for at least 5 seconds when tiny flame is brought near to it. In most cases fire points are 5°C to 40 °C higher than the flash point. The flash and fire points are usually determined by using Cleveland open cup apparatus.

PROCEDURE:

1. The fuel under examination is filled up to the mark in the oil cup and then heated by using electrical heater.
2. Heat is applied so as raise the oil temperature by about 5°C per minute.
3. At every 1°C rise of temperature, flame is introduced for a moment by using matchbox.
4. The temperature at which a distinct flash is noted and the same is flash point.
5. The heating is continued thereafter and the test flame is applied as before.
6. When the oil ignites and continues to burn for at least 5 seconds, the temperature reading is noted and the same is fire point.

TABULAR COLUMN:

Sl. No.	Name of the Oil/Fuel	Flash Point in °C	Fire Point in °C

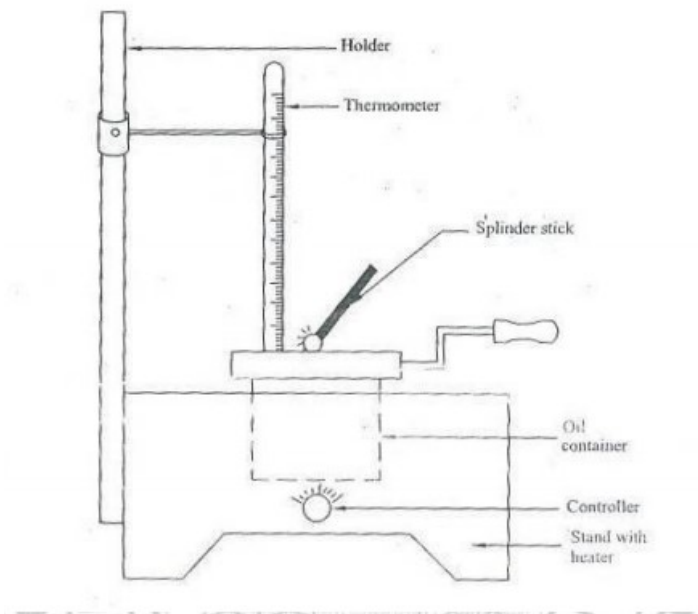

Schematic diagram of Cleveland Open cup apparatus

RESULT:

Thus the Flash and Fire point of the given oil / fuel is found out experimentally.

1. Flash Point _____.
2. Fire Point _____.

VIVA QUESTIONS AND ANSWERS

1. Define the term compression ratio.

Ans: Compression ratio is the ratio between total cylinder volume to clearance volume. It is denoted by the letter 'r'

2. What is the range of compression ratio for SI and diesel engine?

Ans: For petrol of SI engine 6 to 8 and For diesel engine 12 to 18.

3. Which cycle is more efficient for the same compression ratio and heat input, Otto cycle or Diesel cycle? Ans: Otto cycle is more efficient than diesel cycle

4. Write the expression for efficiency of the otto cycle?

Ans:

$$\text{Efficiency } \eta = 1 - \frac{1}{(r)^{\gamma-1}}$$

5. The efficiency of the diesel cycle approaches the otto cycle efficiency when the cut off ratio is _____ (Ans: reduced)

6. Which device is used to control the Air – fuel ratio in the petrol engine? (Ans: Carburettor)

7. Which device is used to control the Air fuel ratio in the diesel engine? (Ans: Injection nozzle)

8. The speed of a four stroke I.C. engine is 1500rpm. What will be the speed of the cam shaft?

Ans: 750 rpm.

9. All the four operations in two stroke engine are performed in _____ number of revolution of crank shaft. (Ans: one)

10. All the four operations in four stroke engine are performed in _____ number of operations?

Ans: Two

VIVA QUESTIONS WITH OUT ANSWERS

1. What is meant by auto ignition temperature?
2. What is the difference between flash point and auto ignition temperature?
3. What is the difference between flash point and fire point?
4. What is the significance of fire and flash points?
5. What are the causes of incomplete combustion?
6. What is enthalpy of combustion? How does it differ from the enthalpy of reaction?
7. What is enthalpy of formation? How does it differ from the enthalpy of combustion?
8. What are the higher and the lower heating values of a fuel? How do they differ? How is the heating value of a fuel related to the enthalpy of combustion of that fuel?
9. What is the nature of enthalpy values for endothermic, exothermic and equilibrium process?
10. Is there any relation between boiling point of a liquid with its flash point?

EXP. NO.:

DATE:

**STUDY OF STEAM GENERATORS (BOILER) AND TURBINES.
BOILERS**

1. INTRODUCTION:

Steam is mainly for power production and other heating purposes. Steam can be classified as wet steam, dry steam and superheated steam. Wet steam is the steam that contains some moisture and there is no moisture present in the dry steam. When dry steam is heated to a higher temperature, the steam becomes superheated steam. Steam is useful for running steam turbines in power stations, steam engines in railway locomotives and in ships. Steam is useful for processing in textile, chemical and sugar industries.

A steam generator is a device used to boil water to create steam. Steam is often fed into a turbine connected to an electrical generator. It can also be used on its own for heating or industrial applications. The steam generators generating steam for process heating are smaller in size and generate low pressure steam. However the steam generators used for power generation are considerably large and generate high pressure steam in very large quantities.

2. CLASSIFICATION OF BOILERS:

The steam boilers are classified as follows:

1. According to the flow of water and hot gases

- a) **Fire tube boilers or smoke tube boilers:** In fire tube boilers, hot gases pass through tubes which are surrounded with water. Eg. Cochran, Lancashire and locomotive boilers.
- b) **Water tube boilers:** In water tube boilers, the water circulates through, the tubes and hot gases flow over the tubes. Eg. Babcock and Wilcox boiler.

2. According to the method of firing or location of furnace

- a) **Internally fired boilers:** In an internally fired boiler, the combustion of fuel takes place inside the boiler shell. Eg. Lancashire and locomotive boilers.
- b) **Externally fired boilers:** In an externally fired boiler, the furnace is placed outside and combustion takes place outside the boiler. Eg. Babcock and Wilcox boiler.

3. According to method of water circulation

- a) **Natural circulation boilers:** The water is circulation by natural convection currents caused by the temperature difference. Eg. Lancashire boiler.
- b) **Forced circulation boilers:** The water is circulation by a pump driven by a motor. Eg. La-Mont boiler, velox boiler.

4. According to the pressure developed

- a) **Low pressure boilers:** the pressure of steam produced is lower than 80bar. Eg. Cochran, Lancashire boilers.
- b) **High pressure boilers:** the pressure of steam produced is greater than 80bar. Eg. . Babcock and Wilcox, Lamont boilers.

5. According to the axis of the shell

1909514 - THERMAL ENGINEERING LABORATORY

- a) **Vertical boilers:** The axis of the shell is vertical. Eg. Cochran boiler.
- b) **Horizontal boilers:** The axis of the shell is horizontal. Eg. Locomotive boiler, Lancashire boiler.

6. According to the use of the boiler

- a) **Stationary boilers:** The boilers are at a fixed place and used for power generation. Eg. Industrial boilers, Babcock and Wilcox boiler.
- b) **Mobile boilers:** The boilers move from one place to another to supply power. Eg. Locomotive boiler.

3. LOW PRESSURE BOILERS

The boilers producing steam at a pressure of less than 80 bar are termed as low pressure boiler. Fire tube boilers are generally preferred for low pressure steam production. Eg. Cochran boiler, Lancashire and Locomotive boilers.

Simple vertical boiler

A simple vertical is shown in fig.28.1. It is an internally fired low pressure vertical fire tube boiler.

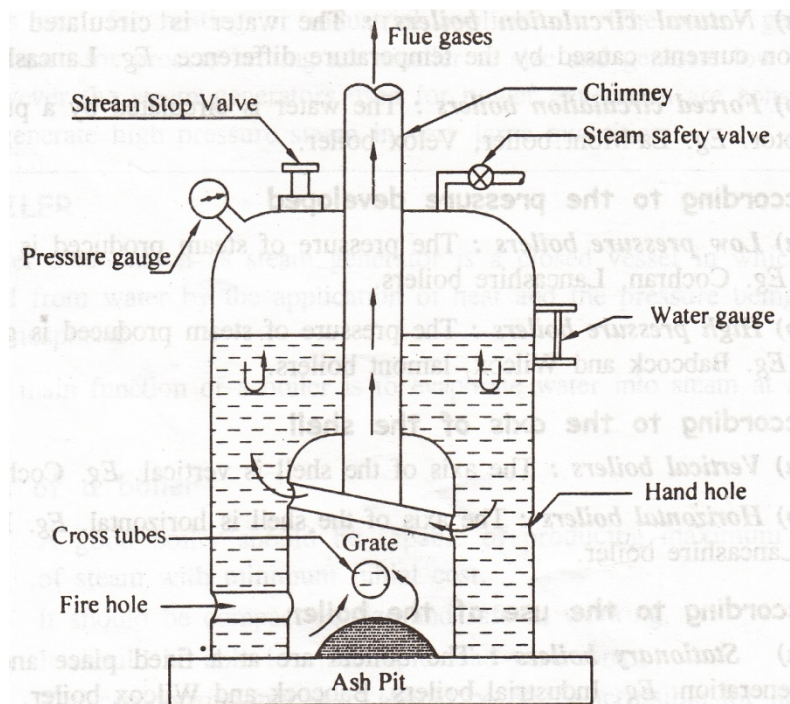

Fig. 28.1 Simple Vertical Boiler

Description

1909514 - THERMAL ENGINEERING LABORATORY

The boiler contains the following parts:

- 1. Cylindrical shell:** The shell is steel plate in cylindrical form attached to the bottom of the furnace. Greater portion of shell is filled with water and the remaining portion is steam space.
- 2. Furnace (or) Firebox:** Furnace is the place where combustion of coal takes place. A grate is provided at the bottom of the furnace on which fuel is burnt. An ashpit is provided for collecting the ash.
- 3. Cross tubes:** One or more cross tubes are laid across the furnace to increase the heating area. They are placed slightly in inclined position to increase the circulation of water.
- 4. Fire hole:** It is provided in front side of the boiler above the grate to let out the exhaust flue gases.
- 5. Hand holes:** Hand holes are provided in the shell for cleaning the cross tubes.

Specification

1	Diameter of the shell	1.5 m
2	Height of the shell	2m
3	Working pressure	7 bar

Working

The fuel is fed into the grate through the fire hole and is burnt. The burnt out fuel is collected as ash in the ash pit placed below the grate. The hot gases flow from the furnace, pass around the cross tubes and heat the surrounding water. Water goes from lower end of the cross tube and comes out from higher end by natural circulation due to convection currents. Steam is produced and gets collected above the water, which is tapped off through a suitable valve.

The following mountings are fitted in the boiler for the safety of boiler and control of steam generation.

- i) Pressure gauge - It** indicates the pressure of steam generated inside the boiler.
- ii) Water gauge -It** indicates the level of water inside the boiler. It is also called water level indicator.
- iii) Safety valve –** It prevents the increase of pressure of steam in the boiler above the desired pressure.
- iv) Stop valve –** It regulates the supply of steam according to the requirements.

4. HIGH PRESSURE BOILER

The boilers producing steam at a pressure of more than 80 bar are termed as high pressure boilers. The high pressure boiler can deliver 40 to 1600 tonnes/hr of superheated steam. Water tubes are generally preferred for high pressure boilers. Eg. Babcock and Wilcox boiler, Lamont boiler, Benson boiler.

BABCOCK AND WILCOX BOILER

Babcock and Wilcox boiler is shown in fig.28.3. It is a horizontal, externally fired, high pressure, water tube boiler.

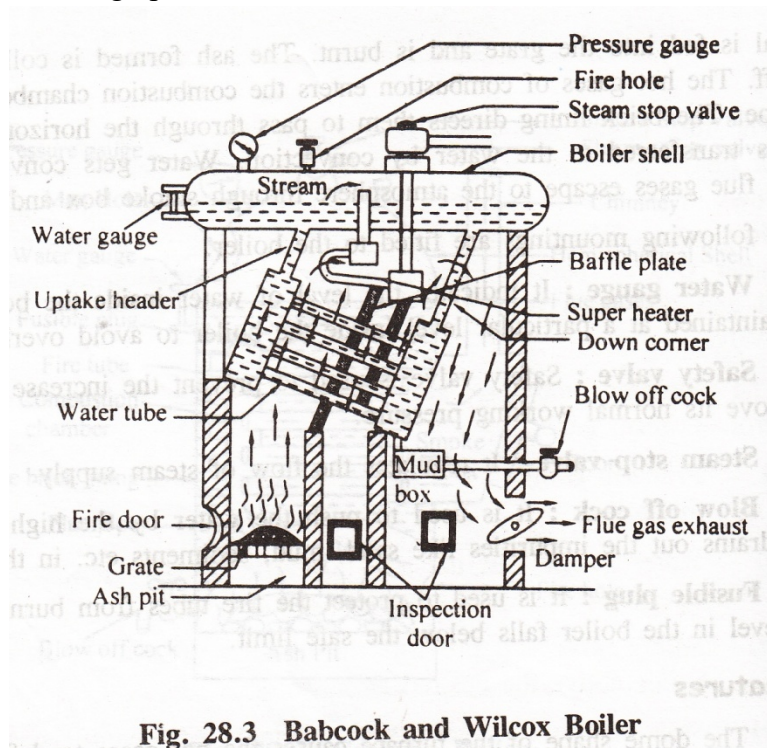

Fig. 28.3 Babcock and Wilcox Boiler

Description

The various parts of the boiler are described below.

1. **Shell (Steam and water drum) :** The drum is horizontal in which half is filled up with water and other half contains steam.
2. **Water tubes:** Number of water tubes are placed between the drum and the furnace at an angle of 10^0 to 15^0 . The water tubes are inclined to promote water circulation.
3. **Uptake header and down comer:** The water tubes are connected to the drum by short tubes at one end called uptake header and by long tubes at other end called down comer or down take header.
4. **Furnace:** A grate is placed below the furnace in which coal is fed through the fire door.
5. **Baffles:** Baffles are provided to deflect the hot gases, and to utilize maximum heat.
6. **Super heater :** The steam collected in the steam space of the drum is allowed to enter into the super heater which is placed above the water tubes.

1909514 - THERMAL ENGINEERING LABORATORY

- 7. Mud box:** It is located at the bottom end of the down comer. The mud, clay particles in the water are collected in the mud box and blown off by means of a blow off cock.
- 8. Inspection doors:** These are provided for cleaning and inspection of the boiler.

Specification

1.	Diameter of the drum	2m
2.	Length of the drum	8m
3.	Working pressure	40 bar
4.	Efficiency	80%

Working

Coal is fed to the grate through the fire door and burnt. Combustion takes place and the hot flue gases coming are get deflected by the baffles up and down. The gases escapes through the chimney after providing maximum heating of water tubes.

The portion of water tubes which is just above the furnace get maximum heat compared to other portions. So water in this portion rises due to decreased density and passes into the drum through uptake header. Here the steam and water gets separated and steam is collected in the upper part since being lighter.

The collected steam passes through the super heater, gets super heater and flows out of the boiler. A damper fitted regulates the flue gas.

The boiler is fitted with the following mountings.

- Pressure gauge and water gauge** to check the pressure and water levels.
- Steam safety valve and steam stop valve** to regulate the steam pressure and steam supply.
- Blow off cock** to remove the mud and sediments.

Salient features

- Overall efficiency is higher.
- All the components are easily accessible for inspection.
- The boiler rests over a rigid structure so that it can expand or contract freely.
- Inclined water tubes provide increased water circulation.
- Draught loss is minimum.

LAMONT BOILER

La-Mont boiler is shown in fig.28.4. It is a water tube, forced circulation type externally fired high pressure boiler.

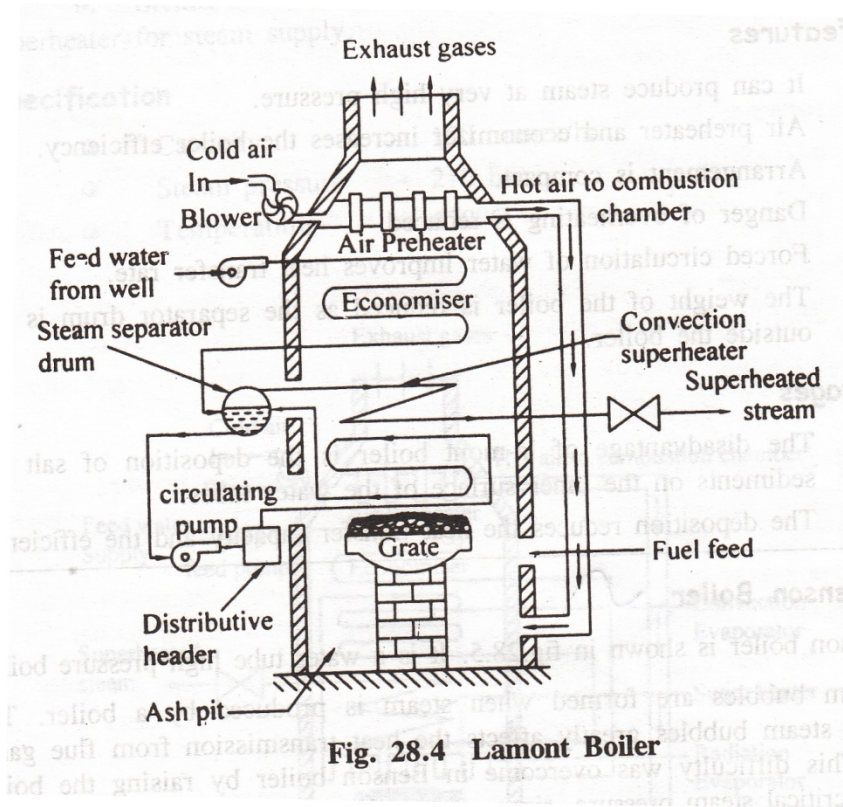

Description

The various parts of the boiler are described below.

1. **Feed pump:** Feed pump supplies the water to the boiler through the economizer.
2. **Economizer:** Economizer is placed inside the boiler at the passage of the flue gases to heat the feed water.
3. **Steam separator drum:** The drum is placed outside the boiler. The steam gets collected above the water in the drum.
4. **Circulating pump:** The circulating pump is placed between the drum and the distributing header. It supplies water under pressure to the distributing header from the drum.
5. **Evaporator:** Evaporator is placed above the grate. Water from the distributing header passes through the evaporator tubes.
6. **Convection super heater :** It is placed above the evaporator./ the steam from the boiler drum passes through the convective super heater.
7. **Air preheater :** The preheater recover some of the heat escaping from the gases which was not extracted by the economizer. It is placed above the economizer.

Specifications

- Capacity – 50 tonnes/hr.
- Steam pressure – 170 bar.
- Temperature – 500⁰C.

1909514 - THERMAL ENGINEERING LABORATORY

Working

Feed water is pumped to the boiler drum by the feed pump through the economizer. Economizer preheats the feed water by using the hot gases leaving the boiler, thereby increasing the efficiency.

The circulating pump circulates the water from the drum under high pressure to prevent the tubes from being overheated. The high pressure water flows through the evaporator and a part of water is converted into steam by the hot gases from the combustion chamber.

Air preheater supplies preheater air for economic combustion.

A mixture of steam and water enters the steam separator drum. Steam gets separated and is in saturated condition. The saturated steam will corrode the turbine blades if used. Hence it is superheated by passing through the convective super heater. The temperature of the steam is raised and the turbine efficiency is improved.

Salient features

1. It can produce steam at very high pressure.
2. Air preheater and economizer increases the boiler efficiency.
3. Arrangement is compact.
4. Danger of overheating is reduced.
5. Forced circulation of water improves heat transfer rate.
6. The weight of the boiler is reduced as the separator drum is kept outside the boiler.

Disadvantages

1. The disadvantages of La-Mont boiler are the deposition of salt and sediments on the inner surface of the water tubes.
2. The deposition reduces the heat transfer capacity and the efficiency.

BENSON BOILER

Benson boiler is shown in fig.28.5. It is a water tube high pressure boiler.

Steam bubbles are formed when steam is produced by a boiler. The presence of steam bubbles greatly affects the heat transmission from flue gases to water. This difficulty was overcome in Benson boiler by raising the boiler pressure to critical steam pressure, since at critical pressure, both water and steam have the same density and no bubbles will form.

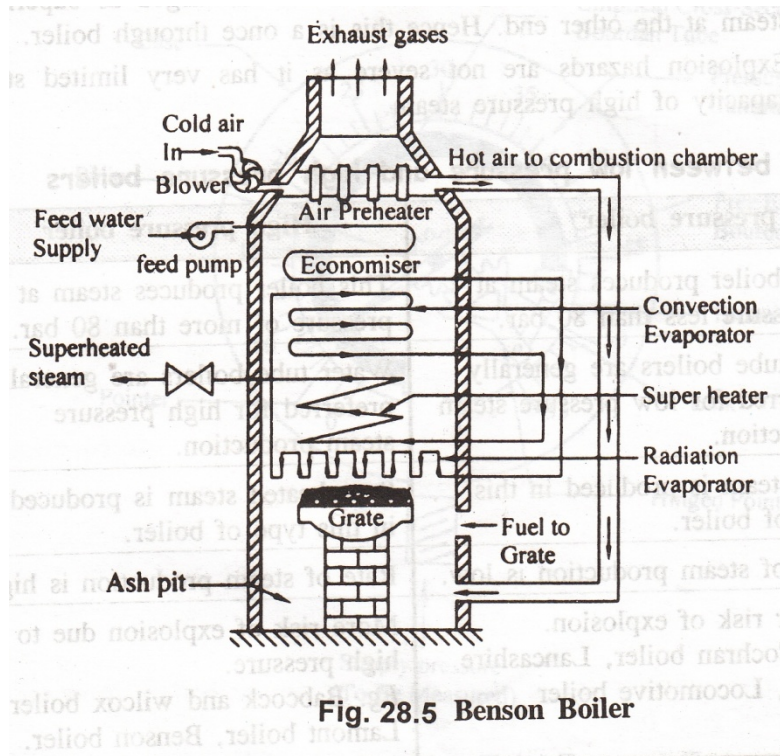

Fig. 28.5 Benson Boiler

Description

Benson boiler contains the following parts.

1. **Feed pump:** Feed pump supplies water to the economizer.
2. **Economizer:** Economizer is placed between the feed pump and convective evaporator. The feed water gets heated in the economizer.
3. **Radiant evaporator:** It is situated close to the furnace. It is called radiant evaporator because heat from the furnace is transferred to the tubes by radiation.
4. **Convection evaporator:** It is placed above the radiant evaporator. Saturated high pressure steam is provided in this evaporator.
5. **Convection super heater :** convection super heater is placed above the convection evaporator. Saturated steam is superheated here.
6. **Steam outlet:** A steam outlet is providing at the end of convection super heater for steam supply.

Specification Capacity - 150 tonnes/hr; Steam pressure - 210 bar; Temperature - 650°C.

Working

In this type of boiler, heating, steam generation and super heating is done in a single stage. The fuel is burnt on the grate and the hot flue gases flow over various devices placed in the path. The feed water is circulated through the economizer tubes and gets heated by the hot flue gases passing over. The heated water then flows into the radiant evaporator and much of the water gets converted into steam by radiation process. The remaining water is evaporated in the convection evaporator by absorbing heat from

1909514 - THERMAL ENGINEERING LABORATORY

hot gases by convection. The saturated steam is passed through the convection super heater, where the steam is superheated to a temperature of 650⁰C. The superheated steam is supplied to the turbine through the steam outlet.

Salient features

1. The boiler is very compact and less weight.
2. Transferring the parts of the boiler is easy as there is no separator drum.
3. The feed water entering at one end is discharged as superheated steam at the other end. Hence this is a once through boiler.
4. Explosion hazards are not severe as it has very limited storage capacity of high pressure steam.

Differences between low pressure and high pressure boilers

S.NO	LOW PRESSURE BOILER	HIGH PRESSURE BOILER
1.	This boiler produces steam at a pressure less than 80 bar.	This boiler produces steam at a pressure more than 80 bar.
2.	Fire tube boilers are generally preferred for low pressure steam production.	Water tube boilers are generally preferred for high pressure steam production.
3.	Dry steam is produced in this type of boiler.	Superheated steam is produced in this type of boiler.
4.	Rate of steam production is low.	Rate of steam production is high.
5.	Lesser risk of explosion. Eg. Cochran boiler, Lancashire boiler, locomotive boiler.	More risk of explosion due to high pressure. Eg. Babcock and Wilcox boiler, Lamont boiler, Benson boiler.

STEAM TURBINES

INTRODUCTION

A steam turbine is a mechanical device that extracts thermal energy from pressurized steam and converts it into useful mechanical work. It has completely replaced the reciprocating piston steam engine primarily because of its greater thermal efficiency and higher power-to-weight ratio. Also, because the turbine generates rotary motion, it is particularly suited to be used to drive an electrical generator-it doesn't require a linkage mechanism to covert reciprocating to rotary motion. The steam, which results in a closer approach to the ideal reversible process

Steam turbines are made in a variety of size ranging from small 1 hp (0.75kW) units used as mechanical drives for pumps, compressors and other shaft driven equipment to 2,000,000 hp (1,500,000 kW) turbines used to generate electricity. To maximize turbine efficiency, the steam is expanded, generating work, in a number of stages. These stage are characterized by how the energy is extract from them and are known as “impulse” or “reaction stage” although most are a combination of the two.

STEAM TURBINE

A steam turbine is a prime mover which converts heat energy in the steam into mechanical work. The main parts of a steam turbine are nozzle, rotor and rotor blades.

Principle

The enthalpy of the steam is first converted into kinetic energy in nozzles. The high velocity steam impinges on the curved blades and the direction of flow of steam is changed. The inflow direction of steam exerts a force on the blades fixed on the rotor and the rotor starts rotating producing power.

Classification of steam turbines

Steam turbines are classified into two groups: Impulse turbine & Reaction turbine

Impulse turbine

In impulse turbines, the steam coming out at a very high velocity through the nozzle impinges on the blades fixed on the periphery of the direction of steam flow without changing its pressure. The resulting force causes the rotation of the turbine's shaft. Eg. De-lavel, Curtis, turbine, Rateau turbine.

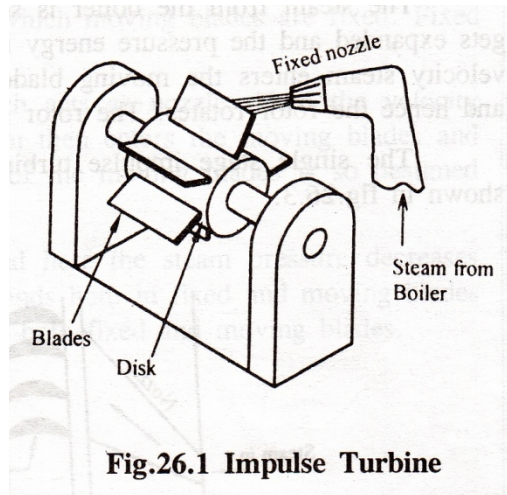

Fig.26.1 Impulse Turbine

Reaction turbine

In reaction turbine, the high pressure steam from the boiler is passed through the nozzle. When the steam comes out through these nozzles, the velocity of steam increases relative to the rotating disc. The resulting force of steam on nozzle gives the rotating to the disc and the shaft. The shaft rotates in opposite direction of the steam jet. Eg. Parson's turbine.

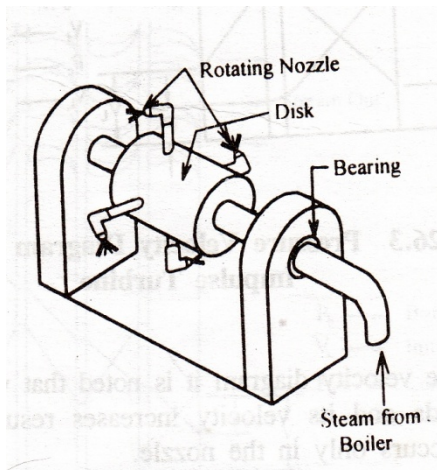

Fig. 26.2 Reaction Turbine

SIMPLE IMPULSE TURBINE (DE-LAVAL TURBINE)

De-Laval turbine is a simple stage impulse turbine. It has one pair of fixed nozzles and moving blades.

The steam from the boiler is sent through the nozzles where the steam gets expanded and the pressure energy is converted into kinetic energy. The high velocity steam enters the moving blades giving up some of the kinetic energy and hence the rotor rotates. The rotor is connected to the output shaft. The single stage impulse turbine and the pressure-velocity diagram are shown in fig.26.3.

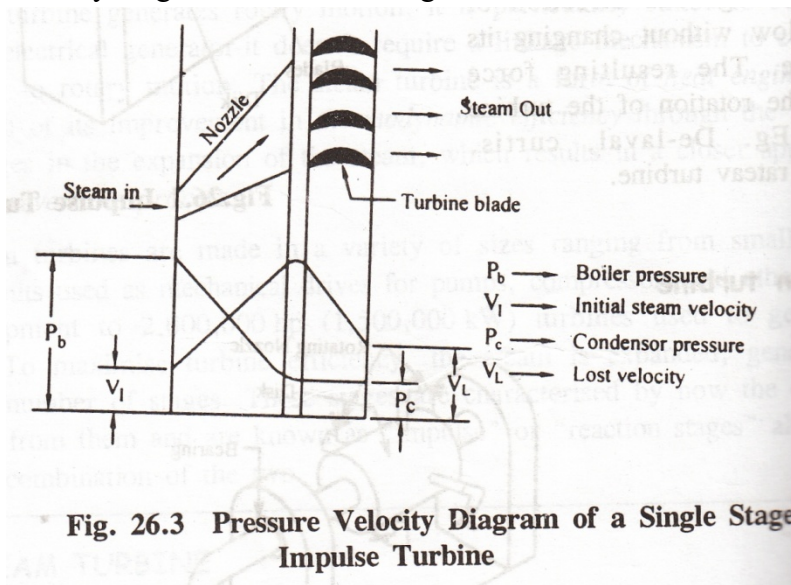

Fig. 26.3 Pressure Velocity Diagram of a Single Stage Impulse Turbine

In the pressure velocity diagram it is noted that when steam passes through the nozzle, it expands and its velocity increases resulting in a pressure drop.

Limitations

- i) De-Laval turbine is only suitable for low pressure steam.
- ii) Since steam expands in one set of nozzles. The outlet velocity of steam is high and rotor will rotate at a very high speed which is not suitable for practical purposes.

REACTION TURBINE (PARSON'S TURBINE)

Parson's turbine is a reaction turbine. In this turbine both fixed blades and moving blades acts as nozzles. Power is obtained by an impulsive force of the incoming steam and reactive force of the outgoing steam.

This turbine consists of a rotor in which acts as nozzle. Here the velocity increases and pressure decreases. The steam then enters the moving blades and the pressure decreases further. The shape of the moving blades is so designed to have the reactive force.

The steam enters the next stage and here the steam pressure decreases and velocity increases. Thus the steam expands both in fixed and moving blades and pressure drop occurs continuously over both fixed moving blades.

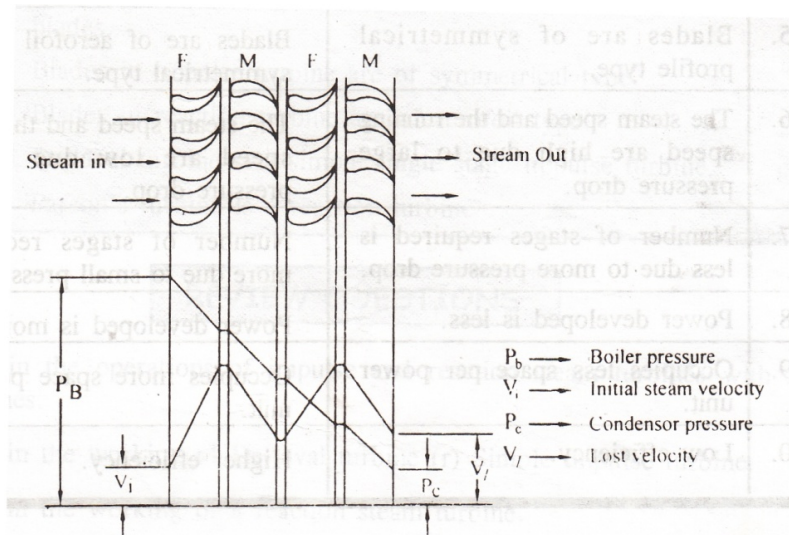

Fig. 26.4 Pressure Velocity Diagram of a Reaction Turbine

DIFFERENCE BETWEEN IMPULSE AND REACTION TURBINES

S.NO.	IMPULSE TURBINE	REACTION TURBINE
1	It consists of nozzle and moving blades.	Steam passes over the blades with pressure and kinetic energy.
2	Steam expands completely in the nozzle	Steam expands both in fixed and moving blades.
3	Pressure drops in nozzle and remains constant in moving blades	Pressure drop occurs gradually and continuously in both fixed and moving blades
4	Relative velocity of steam passing over the moving blades remains constant as there is no pressure	Relative velocity of steam increase in the moving blades as there is continuous expansion of steam

1909514 - THERMAL ENGINEERING LABORATORY

	variation.	
5	Blades are of symmetrical profile drop.	Blades are of aerofoil and non-symmetrical type.
6	The steam speed and the running is less due to large pressure drop.	The steam speed and the running speed are low due to small pressure drop.
7	Number of stage requires is less due to more pressure drop	Number of stage requires is more due to small pressure drop
8	Power developed is less	Power developed is more
9	Occupies less space per power unit	Occupies more space per power unit
10	Low efficiency	Higher efficiency

EXP. NO.:

DATE:

PERFORMANCE TEST ON BOILER.

AIM

To conduct the performance test on steam boiler and to find out the evaporative capacity, Equivalent Evaporation, Factor of Evaporation and Boiler efficiency.

APPARATUS REQUIRED:

Steam boiler with mountings and stop watch.

SPECIFICATIONS:

Boiler	:	REVOMAX, Three pass, Reversible flue, Coil type IBR approved boiler.
Model	:	RXA04
Capacity	:	750 Kg/hr
Fuel	:	High Speed Diesel
Working Pressure	:	15 bar.

PROCEDURE:

1. Fire the boiler using the main control panel board.
2. Run the boiler few min to get steady state.
3. Note the initial level of water in the boiler in the boiler through water level indicator.
4. Adjust the feed water flow, fuel flow and water level at constant level for a uniform flow rate of steam at given pressure.
5. Measure the feed water flow in given time.
6. Conduct the test for different steam pressure.
7. Tabulate the readings.

FORMULAE:

1. Evaporative capacity of the boiler (m_s)

$$= \frac{\text{Mass of water evedorated}}{\text{time}}$$
$$= \frac{Q_w \times \rho_w}{t_w} \text{ in } \left(\frac{Kg}{s} \right)$$

where Q_w - Volume of water consumed = Area of tank X Change in level of water tank.
Area of the tank = m^2
 t_w - time for consuming Q_w m^3 of water in 's'

1909514 - THERMAL ENGINEERING LABORATORY

2. Equivalent Evaporation (m_e):

$$= \frac{\text{Heat gained by the steam}}{\text{Latent heat of Evaporation at } 100^\circ \text{C}}$$

$$= \frac{m_s(h_s - h_m)}{h_{fg} \text{ at } 100^\circ \text{C}}$$

where

m_s - Mass of water evaporated in Kg/h

h_s - Specific enthalpy of steam generated by the boiler = $h_f + x h_{fg}$

where h_f - Specific enthalpy of saturated water at 'p' in KJ/Kg

h_{fg} - Latent heat of evaporation at 'p' in KJ/Kg (h_{fg} at $100^\circ \text{C} = 2257 \text{ KJ/Kg}$)

x - Dryness fraction of steam at 'p'

h_w - Specific enthalpy of water entering the boiler = h_f at 'T' in KJ/Kg

3. Factor of Evaporation (F_e):

$$= \frac{(h_s - h_w)}{h_{fg} \text{ at } 100^\circ \text{C}}$$

4. Boiler efficiency (η_b):

$$= \frac{m_s(h_s - h_w)}{m_f \text{ C.V}}$$

where C.V - Calorific value of fuel (43500 KJ/Kg)

m_f - Mass of fuel consumed / hour

$$= \frac{(Q_f - \rho_d)}{\frac{t_f}{3600}}$$

where Q_f = volume of fuel consumed = Fuel tank area X fall in fuel tank in 'm'

Fuel tank area = m^2

t_f - time for ' Q_f ' m^3 of fuel consumption in 's'

ρ_d - Density of fuel = 860 Kg/ m^3

1909514 - THERMAL ENGINEERING LABORATORY

OBSERVATION

Sl. No.	Steam Pressure	Steam Temperature	Time taken for 5 cm fall of fuel	Time taken for 10 cm fall of water
	P	T	t_f	t_w
	bar	°C	s	s

TABULATION OF RESULTS

Sl. No.	Steam Pressure	Evaporative Capacity	Equivalent Evaporation	Factor of Evaporation	Boiler Efficiency
	p	m_s	m_e	F_e	η_b
	bar	Kg/h	Kg/h		%

RESULT

The performance test on the boiler has been conducted and various parameters are determined.

1909514 - THERMAL ENGINEERING LABORATORY

VIVA QUESTIONS AND ANSWERS

1. How boilers are classified?

(i) According to flow of water and gases (a) Fire tube boiler (b) Water tube boiler (ii) According to pressure (a) Low pressure boiler (b) High Pressure (iii) According to method of firing (a) Internally fired boiler (b) Externally fired boiler

2. List out the advantages of high pressure boiler.

(i) Heat energy per kg of steam is increased at high pressure (ii) Production rate of steam is high. (iii) Superheated steam can be produced.

3. What are the various applications of steam boilers?

(i) Steam produced by the boiler is used for driving steam turbines for power generation (ii) Steam is used in steam engine in railway locomotives. (iii) Steam boiler is also used in industrial applications.

4. What is the purpose of an economizer in boilers?

The purpose of an economizer in a steam boiler is used to preheat the feed water from the tank, before it enters the boiler. 2

5. What is the purpose of superheater in boiler?

A superheater is used to increase the temperature the steam to convert the dry steam into super heated to steam. Superheated steam with high energy content is used to drive the turbine.

6. What is meant by forced circulation boiler?

In forced circulation boiler, water is circulated with high pressure by a pump driven by the motor.

Example: Lamont boiler.

7. What is the purpose of a man hole in the boiler?

A man hole is a provision for a skilled personnel to enter into the boiler shell for cleaning, inspecting or for attending any repairs in the boiler.

8. What is meant by scaling in the boiler? What is its effect?

The impurities that are left behind when water is transformed into steam, forming a thin layer is called scaling in the boiler. When the scaling is more around in a water tube boiler, it leads to poor heat transfer.

9. At what pressure do the modern high pressure boilers produce steam?

Modern high pressure boilers produce steam at a pressure of 200 bar.

10. What is a grate in the boiler?

A grate is a part of the boiler over which solid fuel is burnt.

1909514 - THERMAL ENGINEERING LABORATORY

EX. NO.:

DATE:

PERFORMANCE TEST ON STEAM TURBINE

AIM

To conduct performance test on steam turbine and draw the various characteristics curves.

APPARATUS REQUIRED

1. Steam turbine - Generator Test Rig.
2. Stop watch.

SPECIFICATIONS:

Boiler	:	REVOMAX, Three pass, Reversible flue, Coil type NIBR approved Boiler.
Model	:	RXA04
Capacity	:	750 Kg/hr
Fuel	:	High Speed Diesel
Working Pressure	:	15 bar.

DESCRIPTION:

Steam turbine

The machine is basically a single stage impulse wheel mounted on a shaft carried on ball bearings and enclosed in a pressure tight casing. Metallic glands between wheel and bearings prevent escape of steam. The runner is manufactured using Blades milled & fixed on the wheel. Blades have large clearance at the sides of the wheel. The blade design being such that there is negligible end thrust. blade inlet angle 24 degree and exit 27 degree. Number of Blades 105.

The turbine is coupled to electrical generator mounted on a common sturdy base. A resistance bank loading provided to load the turbine. A panel with ammeter, Voltmeter, Pressure gauges provided to measure the pressure drop across the turbine blades.

A pressure gauge is provided to note the inlet steam pressure and a compound gauge to note the exit steam pressure from the turbine.

Separating and Throttling Calorimeter: -

The combined separating and throttling calorimeter to find the dryness fraction of steam consisting of a steam separator unit with proper insulation gauge glass fittings and a nozzle to throttle the steam. A pressure gauge at proper location. A shell and coil type condenser unit is provided. The apparatus connected to the main steam line through valves.

Steam Condenser:

1909514 - THERMAL ENGINEERING LABORATORY

Shell and tube type, steam flows through the shell and coolant water through the tubes. The tubes are made of copper of 12mm ID and 15mm OD and the number of tubes 36 arranged in square pitch.

PROCEDURE

1. Switch on the boiler with proper feed water supply and diesel supply. Measure the feed water quantity. Lit/sec. Since it is a once through boiler the quantity of steam produced is equal to the quantity of steam produced.
2. Open the bye pass steam valve and run the boiler for few minutes to achieve the rated pressure. Note the Boiler Pressure P and exhaust gas temperature inlet to the economizer T_1 , and out let flue gas temperature T_2 . Note water inlet and outlet temperature to the economizer T_3 and T_4 respectively.
3. Note the fuel consumption.
4. Since the steam supply is from a once through Boiler the outlet quantity of steam can not be adjusted and hence the fuel intake and the air flow rate will remain the same for a required condition of steam.
5. Open the steam inlet valve for the Separating & Throttling calorimeter and note the mass of steam separated (m) and the dry steam condensed (M) for a known interval of time.
6. Note the Pressure of steam in the Throttling calorimeter which approx. equal to the Boiler pressure.
7. Slowly open the inlet steam valve to the Turbine and closing the bye pass valve check the output voltage of the generator.
8. When the rated voltage is obtained slowly apply load in small steps to the generator using the loading rheostat **maintaining the Voltage constant** (Speed) by adjusting the bye pass valve.
9. Slowly increase the load and note the inlet and outlet pressure from the Turbine P_1 and P_2 respectively.
10. Note the Ammeter and Voltmeter readings.

CALCULATION

A. DRYNESS FRACTION:

Seperating & Throttling calorimeter:

Sr. No.	Mass of steam condensed Kg/sec (M)	Mass of steam separated Kg/sec (m)
---------	---------------------------------------	---------------------------------------

1909514 - THERMAL ENGINEERING LABORATORY

--	--	--

$$X = M / M + m$$

B. BOILER TRIAL

The main object of conducting a test or a trial on an existing Steam Boiler is to determine the efficiency and capacity of the Boiler. A complete heat account of the energy input and output including various losses drawn up.

The following observation are taken during a test on a steam Boiler:

Calorific value of fuel: (Cv) KJ/Kg

Sr.No.	Quantity of fuel burnt/hr: (m) Kg/hr	Feed water supplied/hr: (mw) Kg/hr	Steam pressure: P Kg/Cm ²	Temp. of the Exhaust gas inlet to economizer T ₁ °C	Temp. of the Exhaust gas outlet from economizer T ₂ °C	Temp. of economizer water inlet T ₃ °C	Temp. of economizer water outlet T ₄ °C

Heat Balance sheet:

1. Heat input $Q_1 = m \times C_v / 3600$ in KJ/hr

2. Heat to convert water to steam in the Boiler

$$Q_2 = m_w (h - h_w) / 3600 \text{ in KJ/hr}$$

where h = specific enthalpy of steam at Boiler pressure P and water temperature T₄

$$= h_f + X h_{fg}$$

h_w = specific enthalpy of water at Boiler pressure P and water temperature T₄

$$\text{Percentage of heat for producing steam} = Q_1 / Q_2 \times 100 \%$$

3. The economizer functions as a calorimeter. Hence

$$\text{Heat to exhaust } Q_3 = ((T_1 - T_{atm}) / (T_1 - T_2)) \times m_w \times (T_3 - T_4) \times 4.18$$

$$\text{Percentage of Heat to exhaust} = Q_3 / Q_1 \times 100\%$$

1909514 - THERMAL ENGINEERING LABORATORY

4. Unaccounted loss = $1 - (2 + 3) \%$

5. Boiler efficiency :

Actual evaporation (m_a) = Mass of water evaporated m_w / Mass of fuel consumed m

Efficiency of the Boiler = $m_a (h - h_w) / C_v \times 100\%$

where h = specific enthalpy of steam = $h_f + X h_{fg}$ at Boiler pressure P and water temperature T_4

h_w = specific enthalpy of water at Boiler pressure P and water temperature T_4

C. EFFICIENCY OF THE STEAM TURBINE :

S.No	Voltmeter reading V	Ammeter reading A	Turbine Inlet Pressure P₁ Kg/cm²	Turbine Outlet pressure P₂ Kg/cm²	Condensate Flow rate Kg/sec Mwc	

1. Work done by the steam:

The process of steam expanding in the Turbine is steady flow Irreversible adiabatic, the Work done by the steam is given by

$$W = h_1 - h_2.$$

where h_1 = Enthalpy of steam at inlet condition of the Turbine = $h_{1f} + xh_{1fg}$ and

h_2 = Enthalpy of steam at outlet condition of the Turbine = $h_{2f} + xh_{2fg}$.

X is the dryness fraction of steam at inlet and outlet conditions.

NOTE: To find h_1 & h_2 , locate point (1) at turbine inlet pressure & temperature on Molier chart. Assuming isentropic expansion in the turbine, draw straight vertical line to meet turbine outlet pressure line to get point (2).

From steam tables the values can be obtained for 1 kg of steam flow rate.

2. Input energy may be calculated for the steam flow rate $P_i = (h_1 - h_2) \times Mwc$

3. The output power = $V \times A$ watts

4. The efficiency of the Turbine = $P_o / P_i \times 100 \%$.

PROCEDURE TO SHUT DOWN:

1. Take off the load gradually in small steps, opening the bye pass valve, as the turbine tends to race up in the event of sudden complete off loading. Open all drains.
2. Occasionally the turbine rotating assembly can be rolled by means of rotating the coupling by hand to check freeness.
3. Close the main stop valve.
4. For longer periods of Shut down it is desirable to introduce a thin oil film by spraying inside the turbine housing.

RESULT:

The performance and energy balance test on boiler and steam turbine are conducted and necessary curves were drawn.

VIVA QUESTIONS AND ANSWERS

1. What is meant by closed cycle gas turbine?

Ans: In closed cycle gas turbine, the same working fluid is recirculated again and again.

2. What is meant by open cycle gas turbine?

Ans: In open cycle gas turbine, the exhaust gas form turbine is exhausted to the atmosphere and fresh air is taken in compressor for every cycle.

3. Gas turbine is working on ----cycle

Ans: Brayton or Jules cycle.

4. How can we increase the efficiency of the gas turbine?

Ans: By providing inter cooler, re-heater along with heat exchanges.

5. Differentiate open and closed cycle gas turbines.

Open cycle gas turbine	Closed cycle gas turbine
1. Working substance is exhausted to the atmosphere after one cycle.	1. The same working substance is recirculated again and again.
2. Pre-cooler is not required	2. Pre-cooler is required to cool the exhaust gas to the original temperature.
3. High quality fuels are used	3. Low quality fuels are used
4. For the same power developed size and weight of the plant is small	4. Size and weight are bigger.

6. What is the function of intercooler in gas turbines? Where it is placed?

Ans: The intercooler is placed between L.P. and H.P. compressors. It is used to cool the gas coming form L.P. compressor to its original temperature.

1909514 - THERMAL ENGINEERING LABORATORY

7. Why re-heater is necessary in gas turbine? What are its effects?

Ans: The expansion process is very often performed in two sperate turbine stages. The re-heater is placed between the H.P. and L.P. turbines to increase the enthalpy of the exhaust gas coming from H.P. turbine. Effects: 1. Turbine output is increased for the same compression ratio & Thermal efficiency is less.

8. What is the function of regenerator in gas turbine?

Ans: The main function of heat regenerator is to exchange the heat from exhaust gas to the compressed air for preheating before combustion chamber. It increases fuel economy and increase thermal efficiency.

Additional Experiments

PERFORMANCE TEST ON CENTRIFUGAL BLOWER

Aim: To conduct a performance test on centrifugal blower and determine its efficiency.

Apparatus required:

Centrifugal blower test Rig.

Description:

Blowers are used to discharge high volumes of air at low pressures and are used in blast furnaces, cupolas, mines, air-conditioning plants, drying plants, etc.

The test blower is a single stage centrifugal type driven by an electric motor. Air is sucked from the atmosphere by the rotating impeller through the inlet. Due to the centrifugal action of the impeller kinetic energy is imparted to the air and it exits the impeller with high velocity. The air then passes through the spiral casing, where a portion of the kinetic energy is converted into pressure energy before it comes out through the outlet. The pressure rise across a blower is small and is typically measured in cms of water column. Hence the air can be treated as incompressible as it flows through the blower.

The experimental set up consists of a centrifugal blower directly driven by a 5Hp motor. At the blower outlet, a butterfly valve is used to control the discharge. An orifice-meter is fixed in the outlet pipeline to measure the actual discharge. A set of pitot tube and thermometer is provided at the outlet to measure the velocity and temperature. The pitot-tube can also be used to measure the velocity profile at the lower inlet. U-tube manometers are provided to measure the pressure difference across the orifice-meter, in the pitot tubes and the delivery pressure. An energy meter is provided to calculate the input to the blower. Three types of interchangeable impellers- Impellers with radial vanes, backward curved vanes, and forward curved vanes are provided with the test rig to study the effects of different vane types.

Experimental procedure:

1. Ensure the manometer connecting the orifice meter, outlet pressure tap and pitot tubes contain manometer fluid (water) upto half-way mark.
2. Close the delivery valve completely.
3. Start the motor.
4. Open the valve slowly and for various stages of opening observe the following manometer readings.
 - a. Delivery pressure manometer reading-h1 and h2 cm of water
 - b. Orifice meter manometer reading-h3 and h4 cm of water

1909514 - THERMAL ENGINEERING LABORATORY

- c. Pitot tube reading –h5 and h6cm of water.
- d. Energy meter reading for 10 revolutions t sec.
- e. Temperature reading at inlet and outlet of the blower-T1 and T2

Formula:

1. Delivery pressure $H_a = \frac{\rho_w}{\rho_a} (h_1 - h_2)$ m of air.

ρ_w = density of water

ρ_a = density of air

$$\rho_a = \frac{P}{RT}$$

P = pressure at delivery (N/m²)

R = 8.314 KJ/KgK

T = temperature at out let of the blower (T2) in K

$$P = \rho_w \times g \times (h_1 - h_2) \quad \text{N/m}^2$$

2. Discharge: $Q = C_d \cdot \frac{a_1 \cdot a_2 \cdot \sqrt{2g((H_o) \text{ m of air})}}{\sqrt{a_1^2 - a_2^2}}$

H_o = pressure head developed in orifice meter.

$$H_o = \frac{\rho_w}{\rho_a} (h_3 - h_4) \text{ m of air.}$$

$$C_d = 0.62$$

a_1 = delivery pipe area (dia. $d_1 = 0.131$ m) = 0.01348 m²

Orifice-meter diameter ratio = 0.75

$$\frac{d_2}{d_1} = 0.75$$

3. Output of the blower

$$\text{Output} = \frac{\rho g Q H_a}{1000} \text{ KW}$$

ρ = Density of air kg/m³

g = 9.81 acceleration due to gravity

Q = discharge

H_a = delivery pressure head

4. Input power of the blower

1909514 - THERMAL ENGINEERING LABORATORY

$$\text{Input} = \frac{N}{t} \times \frac{3600}{k} \text{ KW}$$

N = no. of revolution

t = time taken for no. of revolution (energy meter disc)

k = energy meter constant (1600 revs/kw Hr)

5. Efficiency = $\frac{\text{output}}{\text{input}} \times 100 = \text{-----}\%$

6. Velocity of the air $V = \sqrt{2gh}$

$$h = \frac{\rho_w}{\rho_a} (h_5 - h_6) \text{ m of air.}$$

1909514 - THERMAL ENGINEERING LABORATORY

S.No	Fan type	Value position	Delivery pressure		Discharge orifice meter		Pitot tube reading velocity			Time for 10 revs of energy meter T sec	Blower input I KW	Blower output O KW	Efficiency %
			h1 m of water	h2 m of water	Ha m of air	h3 m of water	h4 m of water	h1 m of water	Velocity m/sec				

RESULT:

Thus we conducted the performance test on centrifugal blower and determine its efficiency.

$$\eta = \text{-----}\%$$

1909514 - THERMAL ENGINEERING LABORATORY

STUDY AND PRACTICAL DEMONSTRATION ON TWIN CYLINDER DIESEL ENGINE WITH WASTE HEAT RECOVERY SYSTEM

AIM:

To conduct a load test on 4-stroke, Twin cylinder diesel engine, to study its performance under various loads.

EQUIPMENT/APPARATUS:

1. 4- Stroke, twin cylinder Diesel engine with a hydraulic dynamometer.
2. Stopwatch.

SPECIFICATIONS:

Make	:	Kirloskar model AVI
Bore	:	87.5mm
Stroke	:	110 mm
No of cylinders	:	2
Rated Speed	:	1500 rpm
Max. B.P	:	10KW
Compression Ratio	:	16 .5:1
Orifice Diameter	:	25mm
Fuel	:	Diesel
Density of Diesel	:	0.827 gm / ml
Calorific Value of Diesel	:	45,350 KJ / kg

DESCRIPTION:

This is a water cooled twin cylinder vertical diesel engine is coupled to a hydraulic dynamometer arrangement to absorb the power produced. Separate cooling water lines are provided for the engine cooling. Thermocouples are provided for measuring temperature. A fuel measuring system consists of a fuel tank mounted on a stand, burette, and a 3-way cock. Air consumption is measured by using a M.S. tank, which is fitted with a standard orifice and a U-tube water manometer that measures the pressures inside the tank.

THEORY:

Twin cylinder stationary, constant speed diesel engines are generally quality governed. As such the air supplied to the engine is not throttled as in the case of S.I. engines.

To meet the power requirements of the shaft, the quantity of fuel injected into the cylinder is varied by the rack in the fuel pump.

The rack is usually controlled by a governor or by a hand.

The air flow rate of twin cylinder engine operating at constant speed does not vary appreciably with the output of the engine.

Since the fuel flow rate varies more or less linearly with output, the fuel air ratio increases with output.

Performance tests can be conducted either at constant speed (or) at constant throttle.

The constant speed method yields the F.P. of the engine.

1909514 - THERMAL ENGINEERING LABORATORY

STARTING THE ENGINE:

1. Engage de-compression lever before cranking.
2. Crank the engine and disengage the de-compression lever.
3. Adjust the governor to attain the rated speed.

PROCEDURE:

1. Open the three way cock so that fuel flows to the engine directly from the tank.
2. Open the cooling water valves and ensure water flows through the engine.
3. Start the engine and allow running on no load condition for few minutes.
4. Open the water line to the hydraulic dynamometer
5. Load engine with hydraulic dynamometer-loading is done by turning the handle in the direction marked. If sufficient load is not absorbed by the dynamometer at the required speed, the outlet valve in the dynamometer can be closed to increase the pressure (as indicated by the pressure gauge) and hence the load.
6. Allow the engine to run at no load for few minutes.
7. Note the following readings a) Engine speed. b) Hydraulic dynamometer reading. . c) Manometer d) Time for 10 cc of fuel consumption
8. Repeat the above procedure at different loads.
9. Stop the engine after removing load on the engine.

Result:

1909514 - THERMAL ENGINEERING LABORATORY

DIS-ASSEMBLY AND ASSEMBLY OF AN ENGINE.

AIM:

To study the procedure for dis-assembly and assembly of a specific engine by making a practical trail on it.

THEORY:

The main parts of any engine are, Cylinder Block:

1. It forms the basic frame work of the engine.
2. It houses the engine cylinders.
3. Serves as bearing or support and guides the piston reciprocating in it.
4. Block contains passages for circulation of cooling water and lubricating.

There are two types of rings

- a) Compression ring
- b) Oil control ring

Connecting rod: It connects the piston with the crank shaft thus facilitative the transmission of power combustion chamber to the crank shaft it also converts the reciprocating motion of the piston into rotary motion of crank shaft.

Fly wheel: The fly wheel absorbs the energy power source and gives out this energy the other 3-strokes keeping the crank shaft rotating at uniform speed through out.

Cam shaft : A shaft is responsible for opening the valves on addition the crank shaft operates.

Cylinder head:

1. The head is a mano block casting.
2. It contains spark plug notes and cooling water Sackets, valve opening mechanism is mounted.
3. Complete valve opening mechanism is mounted on the head.

Piston:

The top of the piston is called head or crown it may be either done are may specially to form a desired shape of combustion chamber jointly with the cylinder block.

Piston pin:

It provides a seal b/w the piston fuel pump. Oil pump and distributor valves.

Valves:

These are accurate by the cams which in turn are operated by crank shaft and perform following functions.

1909514 - THERMAL ENGINEERING LABORATORY

PROCEDURE FOR ENGINE DIS-ASSEMBLY.

For dis-assembly the engine, it should be mounted in a suitable stand. Engine disassembly is carried out in a sequence as follows and engine is out of the vehicle and all the accessories have been removed and oil has been drained.

- Remove water pump.
- Remove exhaust manifold
- Remove oil filter
- Remove water outlet fitting
- Remove thermostat
- Remove crank shaft pulley
- Remove oil pump
- Remove crank case ventilation valve
- Remove rocker arm assembly
- Remove cylinder head.
- Remove oil pan.
- Remove piston rod and connecting rod.
- Remove timing gear cover.
- Remove front end plate.
- Remove fly wheel housing.
- Remove fly wheel, clutch
- Remove crank shaft.
- Remove exhaust valve and springs.
- Remove cam shaft, valve tappers.
- Remove oil gallery plugs.

PROCEDURE FOR ENGINE DIS-ASSEMBLY.

First clean the cylinder block with fresh oils. Piston is connected to connecting rod with gudge pin. This piston have the piston rings.

After fixing the rings piston is inserted in to the cylinder block with help of ring compressor.

These rings are fitted in the piston grooves with help of calipers.

1909514 - THERMAL ENGINEERING LABORATORY

The crank shaft has been placed on the bottom of the cylinder block the connecting rod is connected to its crank.

The fly wheel is attached to the crank shaft one side.

On the other side of the crank shaft timing gear is fitted. It is for valve operating.

This equipment is placed on the sump of the engine.

After fixing on the sump the cam shafts are fitted in the cylinder head in the inlet valve & exhaust valves are fitted with help of G-clamp

To this cylinder the intake manifold and injectors are fitted one side.

Other side of the cylinder head the exhaust manifold is fitted.

Fill the sump with new oil.

After fill up the oil the water pump is fitted.

The thermostat is also fitted to this engine then the re assembly of the given engine is completed.

RESULT:

Thus the procedure of the assembling of a engine is studied and recorded.

1909514 - THERMAL ENGINEERING LABORATORY

Multiple choice questions with answers for competitive exams

1. The working cycle in case of four stroke engine is completed in following number of revolutions of crankshaft

- (a) 1/2
- (b) 1
- (c) 2
- (d) 4
- (e) 8.

Ans: c

2. In a diesel engine, the fuel is ignited by

- (a) spark
- (b) injected fuel
- (c) heat resulting from compressing air that is supplied for combustion
- (d) ignitor
- (e) combustion chamber.

Ans: c

3. Scavenging air in diesel engine means

- (a) air used for combustion sent under pres-sure
- (b) forced air for cooling cylinder
- (c) burnt air containing products of com-bastion
- (d) air used for forcing burnt gases out of engine's cylinder during the exhaust period
- (e) air fuel mixture.

Ans: d

4. Supercharging is the process of

- (a) supplying the intake of an engine with air at a density greater than the density of the surrounding atmosphere
- (b) providing forced cooling air
- (c) injecting excess fuel for raising more load
- (d) supplying compressed air to remove combustion products fully
- (e) raising exhaust pressure.

Ans: a

5. Does the supply of scavenging air at a density greater than that of atmosphere mean engine is supercharged ?

- (a) yes
- (b) no
- (c) to some extent
- (d) unpredictable
- (e) depends on other factors.

1909514 - THERMAL ENGINEERING LABORATORY

Ans: b

6. The ratio of indicated thermal efficiency to the corresponding air standard cycle efficiency is called

- (a) net efficiency
- (b) efficiency ratio
- (c) relative efficiency
- (d) overall efficiency
- (e) cycle efficiency.

Ans: c

7. Compression ratio of LC. engines is

- (a) the ratio of volumes of air in cylinder before compression stroke and after compression stroke
- (b) volume displaced by piston per stroke and clearance volume in cylinder
- (c) ratio of pressure after compression and before compression
- (d) swept volume/cylinder volume
- (e) cylinder volume/swept volume.

Ans: a

8. The air standard efficiency of an Otto cycle compared to diesel cycle for the given compression ratio is

- (a) same
- (b) less
- (c) more
- (d) more or less depending on power rating
- (e) unpredictable.

Ans: c

9. The calorific value of gaseous fuels is expressed in terms of

- (a) kcal
- (b) kcal/kg
- (c) kcal/m²
- (d) kcal/n?
- (e) all of the above.

Ans: d

10. If the intake air temperature of I.C. engine increases, its efficiency will

- (a) increase
- (b) decrease
- (c) remain same
- (d) unpredictable
- (e) depend on other factors.

Ans: b

11. All heat engines utilize

- (a) low heat value of oil
- (b) high heat value of oil

1909514 - THERMAL ENGINEERING LABORATORY

- (c) net calorific value of oil
- (d) calorific value of fuel
- (e) all of the above.

Ans: a

12. An engine indicator is used to determine the following

- (a) speed
- (b) temperature
- (c) volume of cylinder
- (d) m.e.p. and I.H.P.
- (e) BHP.

Ans: d

13. Fuel oil consumption guarantees for I.C. engine are usually based on

- (a) low heat value of oil
- (b) high heat value of oil
- (c) net calorific value of oil
- (d) calorific value of fuel
- (e) all of the above.

Ans: b

14. If the compression ratio of an engine working on Otto cycle is increased from 5 to 7, the %age increase in efficiency will be

- (a) 2%
- (b) 4%
- (c) 8%
- (d) 14%
- (e) 27%.

Ans: d

15. In case of gas turbines, the gaseous fuel consumption guarantees are based on

- (a) high heat value
- (b) low heat value
- (c) net calorific value
- (d) middle heat value
- (e) calorific value.

Ans: b

16. In a typical medium speed 4-stroke cycle diesel engine the inlet valve

- (a) opens at 20° before top dead center and closes at 35° after the bottom dead center
- (b) opens at top dead center and closes at bottom dead center
- (c) opens at 10° after top dead center and closes 20° before the bottom dead center
- (d) may open or close anywhere
- (e) remains open for 200° .

Ans: a

1909514 - THERMAL ENGINEERING LABORATORY

17. The pressure and temperature at the end of compression stroke in a petrol engine are of the order of

- (a) 4 - 6 kg/cm² and 200 - 250°C
- (b) 6 - 12 kg/cm² and 250 - 350°C
- (c) 12 - 20 kg/cm² and 350 - 450°C
- (d) 20 - 30 kg/cm² and 450 - 500°C
- (e) 30 - 40 kg/cm² and 500 - 700°C.

Ans: b

18. The pressure at the end of compression in the case of diesel engine is of the order of

- (a) 6 kg/cm
- (b) 12kg/cmz
- (c) 20 kg/cmz
- (d) 27.5 kg/cmz
- (e) 35 kg/cm

Ans: e

19. The maximum temperature in the I.C. engine cylinder is of the order of

- (a) 500- 1000°C
- (b) 1000- 1500°C
- (c) 1500-2000°C
- (d) 2000-2500°C
- (e) 2500-3000°C

Ans: d

20. The thermal efficiency of a diesel cycle having fixed compression ratio, with increase in cut-off ratio will

- (a) increase
- (b) decrease
- (c) be independent
- (d) may increase or decrease depending on other factors
- (e) none of the above.

Ans: b

21. Pick up the wrong statement

- (a) 2-stroke engine can run in any direction
- (b) In 4-stroke engine, a power stroke is obtained in 4-strokes
- (c) thermal efficiency of 4-stroke engine is more due to positive scavenging
- (d) petrol engines work on to cycle
- (e) petrol engines occupy more space than diesel engines for same power output.

Ans: e

22. Combustion in compression ignition engines is

- (a) homogeneous
- (b) heterogeneous
- (c) both (a) and (b)

1909514 - THERMAL ENGINEERING LABORATORY

- (d) laminar
- (e) turbulent.

Ans: b

23. The fuel in diesel engine is normally injected at pressure of

- (a) 5-10 kg/cm²
- (b) 20-25 kg/cm²
- (c) 60-80 kg/cm²
- (d) 90-130 kg/cm²
- (e) 150-250 kg/cm²

Ans: d

24. The specific fuel consumption per BHP hour for diesel engine is approximately

- (a) 0.15 kg
- (b) 0.2 kg
- (c) 0.25 kg
- (d) 0.3 kg
- (e) 0.35 kg.

Ans: b

25. The temperature of interior surface of cylinder wall in normal operation is not allowed to exceed

- (a) 80°C
- (b) 120°C
- (c) 180°C
- (d) 240°C
- (e) 320°C.

Ans: c

26. Crankcase explosion in I.C. engines usually occurs as

- (a) first a mild explosion followed by a big explosion
- (b) first a big explosion followed by a mild explosion
- (c) both mild and big explosions occur simultaneously
- (d) never occurs
- (e) unpredictable.

Ans: a

27. Compression loss in I.C engines occurs due to

- (a) leaking piston rings
- (b) use of thick head gasket
- (c) clogged air-inlet slots
- (d) increase in clearance volume caused by bearing-bushing wear
- (e) all of the above.

Ans: e

28. The specific fuel consumption per BHP hour for a petrol engine is approximately

- (a) 0.15 kg

1909514 - THERMAL ENGINEERING LABORATORY

- (b) 0.2 kg
- (c) 0.25 kg
- (d) 0.3kg
- (e) 0.35 kg.

Ans: c

29. The air requirement of a petrol engine during starting compared to theoretical required for complete combustion is

- (a) more
- (b) loss
- (c) same
- (d) may be more or less depending on engine capacity
- (e) unpredictable.

Ans: b

30. The inlet valve of a four stroke cycle I.C engine remains open for nearly

- (a) 180°
- (b) 125°
- (c) 235°
- (d) 200°
- (e) 275°.

Ans: c

31. Which of the following is not an internal combustion engine

- (a) 2-stroke petrol engine
- (b) 4-stroke petrol engine
- (c) diesel engine
- (d) gas turbine
- (e) steam turbine.

Ans: e

32. Pick up the false statement

- (a) Thermal efficiency of diesel engine is about 34%
- (b) Theoretically correct mixture of air and petrol is approximately 15 : 1
- (c) High speed compression engines operate on dual combustion cycle
- (d) Diesel engines are compression ignition engines
- (e) S.I. engines are quantity-governed engines.

Ans: e

33. If one cylinder of a diesel engine receives more fuel than the others, then for that cylinder the

- (a) exhaust will be smoky
- (b) piston rings would stick into piston grooves
- (c) exhaust temperature will be high
- (d) engine starts overheating
- (e) scavenging occurs.

Ans: e

1909514 - THERMAL ENGINEERING LABORATORY

34. The output of a diesel engine can be increased without increasing the engine revolution or size in following way

- (a) feeding more fuel
- (b) increasing flywheel size
- (c) heating incoming air
- (d) scavenging
- (e) supercharging.

Ans: e

35. If the temperature of intake air in IC engines is lowered, then its efficiency will

- (a) increase
- (b) decrease
- (c) remain same
- (d) increase upto certain limit and then decrease
- (e) decrease upto certain limit and then increase.

Ans: a

36. In a typical medium speed 4-stroke cycle diesel engine

- (a) compression starts at 35° after bottom dead center and ends at top dead center
- (b) compression starts at bottom dead center and ends at top dead center
- (c) compression starts at 10° before bottom dead center and, ends just before top dead center
- (d) may start and end anywhere
- (e) none of the above.

Ans: a

37. For the same compression ratio

- (a) Otto cycle is more efficient than the Diesel
- (b) Diesel cycle is more efficient than Otto
- (c) both Otto and Diesel cycles are, equally efficient
- (d) compression ratio has nothing to do with efficiency
- (e) which is more efficient would depend on engine capacity.

Ans: a

38. The process of breaking up of a liquid into fine droplets by spraying is called

- (a) vaporisation
- (b) carburetion
- (c) ionisation
- (d) injection
- (e) atomisation.

Ans: e

39. As a result of detonation in an I.C. engine, following parameter attains very high value

- (a) peak pressure
- (b) rate of rise of pressure

1909514 - THERMAL ENGINEERING LABORATORY

- (c) rate of rise of temperature
- (d) peak temperature
- (e) rate of rise of horse-power.

Ans: b

40. Which of the following statements is correct?

- (a) All the irreversible engines have same efficiency
- (b) All the reversible engines have same efficiency
- (c) Both Rankine and Carnot cycles have same efficiency between same temperature limits
- (d) All reversible engines working between same temperature limits have same efficiency
- (e) Between same temperature limits, both petrol and diesel engines have same efficiency.

Ans: d

41. Most high speed compression engines operate on

- (a) Diesel cycle
- (b) Otto cycle
- (c) Dual combustion cycle
- (d) Special type of air cycle
- (e) Carnot cycle.

Ans: c

42. The accumulation of carbon in a cylinder results in increase of

- (a) clearance volume
- (b) volumetric efficiency
- (c) ignition time
- (d) effective compression ratio
- (e) valve travel time.

Ans: d

43. Which of the following medium is compressed in a Diesel engine cylinder

- (a) air alone
- (b) air and fuel
- (c) air and lub oil
- (d) fuel alone
- (e) air, fuel and lub oil.

Ans: a

44. The air-fuel ratio of the petrol engine is controlled by

- (a) fuel pump
- (b) governor
- (c) injector
- (d) carburettor
- (e) scavenging.

Ans: d

1909514 - THERMAL ENGINEERING LABORATORY

45. In a typical medium speed, 4-stroke cycle diesel engine
- (a) fuel injection starts at 10° before to dead center and ends at 20° after top dead center
 - (b) fuel injection starts at top dead center and ends at 20° after top dead center
 - (c) fuel injection starts at just before top dead center and ends just after top dead center
 - (d) may start and end anywhere
 - (e) none of the above.

Ans: a

46. Diesel fuel, compared to petrol is
- (a) less difficult to ignite
 - (b) just about the same difficult to ignite
 - (c) more difficult to ignite
 - (d) highly ignitable
 - (e) none of the above.

Ans: c

47. In diesel engine the diesel fuel injected into cylinder would burn instantly at about compressed air temperature of
- (a) 250°C
 - (b) 500°C
 - (c) 1000°C
 - (d) 150°C
 - (e) 2000°C .

Ans: c

48. When crude oil is heated, then which of the following hydrocarbon is given off first.
- (a) kerosene
 - (b) gasoline
 - (c) paraffin
 - (d) diesel
 - (e) natural gas.

Ans: e

49. The rating of a diesel engine, with increase in air-inlet temperature, will
- (a) increase linearly
 - (b) decrease linearly
 - (c) increase parabolically
 - (d) decrease parabolically
 - (e) first decrease linearly and then increase parabolically.

Ans: b