

# **SRM VALLIAMMAI ENGINEERING COLLEGE**

**(An Autonomous Institution)**

SRM Nagar, Kattankulathur – 603 203

**DEPARTMENT OF ELECTRICAL AND ELECTRONICS ENGINEERING**

**QUESTION BANK**



**VII SEMESTER**

**EE8702-Power System Operation and Control**

**Regulation – 2017**

**Academic Year 2021-22**

*Prepared by*

**Mr. S. Rajanbabu, Assistant Professor (Sel.Gr.) / EEE**

**UNIT I - PRELIMINARIES ON POWER SYSTEM OPERATION AND CONTROL**

Power scenario in Indian grid – National and Regional load dispatching centers – requirements of good power system - necessity of voltage and frequency regulation – real power vs frequency and reactive power vs voltage control loops - system load variation, load curves and basic concepts of load dispatching - load forecasting - Basics of speed governing mechanisms and modeling - speed load characteristics - regulation of two generators in parallel

**PART - A**

Q.No	Questions	Course Outcome	BT Level	Competence
1	What are the load dispatch centres in India	CO1	1	Remember
2	List out the requirement of good power system	CO1	4	Analyze
3	What are the functions of RLDC and NLDC	CO1	1	Remember
4	Demonstrate the term average load.	CO1	4	Analyze
5	Define connected load	CO1	1	Remember
6	What is meant by daily load curve	CO1	2	Understand
7	Differentiate load curve and load duration curve.	CO1	4	Analyze
8	What are the major control loops used in large generators	CO1	2	Understand
9	Draw the ideal speed droop characteristics of a speed governor	CO1	2	Understand
10	What is the need for load forecasting?	CO1	3	Apply
11	Mention different types of to find load forecasting	CO1	3	Apply
12	What is the necessity to regulate voltage and frequency in the power system?	CO1	2	Understand
13	Evaluate significance of governor control and system voltage control.	CO1	1	Remember
14	Define load factor	CO1	1	Remember
15	What is present power scenario in India	CO1	2	Understand
16	Show the conditions necessary for sharing load operating in parallel between the two synchronous machines.	CO1	4	Analyze
17	List the components of speed governing mechanism.	CO1	4	Analyze
18	What is meant by free governor operation?	CO1	5	Evaluate
19	A speed governor system cannot completely eliminate frequency error caused by a step load change in power system. Evaluate this statement.	CO1	5	Evaluate
20	Contrast the functions of “speed Governor” and “speed changer” in a speed governing system of a turbine generator set.	CO1	6	Create

**PART-B**

1	Explain with the detail necessity of voltage and frequency regulation in power system (13)	CO1	1	Remember												
2	(i) Explain role of NLDC & RLDC in power system (6) (ii) List out the current power scenario in India (7)	CO1 CO1	2	Understand												
3	i) Analyze the need for voltage and frequency regulation in power system. (5) ii) A generating station has maximum demand of 400 MW. The annual load factor is 65% and capacity factor is 50% analyse the reserve capacity of the plant. (8)	CO1 CO1	3	Apply												
4	What are the components of speed governor system of an alternator? Derive the mathematical model of speed governor system with aid of block diagram (13)	CO1	4	Analyze												
5	A generating station has the following daily load cycle: <table border="1" style="margin-left: auto; margin-right: auto;"> <tr> <td>Time</td> <td>12-5am</td> <td>5-9am</td> <td>9am-6pm</td> <td>6pm-10pm</td> <td>10pm-12am</td> </tr> <tr> <td>Load(MW)</td> <td>20</td> <td>40</td> <td>80</td> <td>100</td> <td>20</td> </tr> </table> <p>Examine the load curve and load duration curve. Calculate load factor of the plant, maximum demand and energy supplied by the plant in 24 hours. If the plant as installed capacity 125MW find the capacity factor and utilisation factor. (13)</p>	Time	12-5am	5-9am	9am-6pm	6pm-10pm	10pm-12am	Load(MW)	20	40	80	100	20	CO1	5	Evaluate
Time	12-5am	5-9am	9am-6pm	6pm-10pm	10pm-12am											
Load(MW)	20	40	80	100	20											
6	Two synchronous generators operating in parallel. Their capacities are 300MW and 400MW. The droop characteristics of their governors are 4% and 5% from no load to full load. Assuming that the generators are operating at 50HZ at no load, how would be a load of 600MW shared between them. Calculate the system frequency at this load? Assume free governor action. (13)	CO1	6	Create												
7	Two 1000KW alternators operate in parallel. The speed regulation of first alternator is 100% to 103% from full load to no load and that of other 100% to 105%. Show how will the two alternators share load of 1200KW and at what will one machine cease to supply any portion of the load. (13)	CO1	3	Apply												
8	Draw the load curve and load duration curve. Also explain the importance of these curves in connection with economic operation of power system (13)	CO1	2	Understand												

9	<p>a) Define the following: Connected load, Average demand, Diversity factor, Plant capacity factor and base load (6)</p> <p>b) A generating station has the following daily load cycle</p> <table border="1"> <thead> <tr> <th>Time in (hrs)</th> <th>0-6</th> <th>6-10</th> <th>10-12</th> <th>12-16</th> <th>16-20</th> <th>20-24</th> </tr> </thead> <tbody> <tr> <td>Load(MW)</td> <td>40</td> <td>50</td> <td>60</td> <td>50</td> <td>70</td> <td>40</td> </tr> </tbody> </table> <p>Draw the load curve and calculate maximum demand, units generated per day, average load and load factor. (7)</p>	Time in (hrs)	0-6	6-10	10-12	12-16	16-20	20-24	Load(MW)	40	50	60	50	70	40	CO1 CO1	1 4	Remember Analyze
Time in (hrs)	0-6	6-10	10-12	12-16	16-20	20-24												
Load(MW)	40	50	60	50	70	40												
10	<p>(i) Demonstrate the basic approach of quadratic curve fitting technique of load forecasting with a suitable example (7)</p> <p>(ii) Compare load curve and load duration curve. (6)</p>	CO1 CO1	2 4	Understand, Analyze														
11	<p>(i) What is the need of a governing mechanism? Illustrate with neat diagram the operation of speed governing mechanism. (7)</p> <p>(ii) Analyze the governor speed droop characteristics, the basic of load sharing between two synchronous machines in parallel. (6)</p>	CO1 CO1	6 4	Create Analyze														
12	Two generators rated 400MW and 700MW are operated in parallel. The droop characteristics of their governors are 3% and 4% respectively from no load to full load. Assuming that the governors are operating in 50Hz at no load, how would a load of 1000MW be shared between them? What will be the system frequency at this load? Assume linear governor operation. Determine the full load speed for each machine. (13)	CO1	4	Analyze														
13	Draw the P - f and Q - V control chart of a synchronous generator and explain how voltage and frequency are maintained constant (13)	CO1	2	Understand														
14	Derive an expression for load sharing between two alternators. Also list out the effects of fuel supply and change of excitation (13)	CO1	6	Create														
<b>PART-C</b>																		
1	What is the necessity of load forecasting and explain different methods load forecasting techniques in power system. (15)	CO1	4	Analyze														
2	<p>Consider an inductive load <math>Z=R+jX</math>.</p> <p>(i) Evaluate by how much percentage the real load drop, if the value is reduced by 5%? (8)</p> <p>(ii) Evaluate how 2% drop in frequency affect the real load; if the load power factor is 0.8 derive the relations used. (7)</p>	CO1	5	Evaluate														

3	<p>Two generators rated at 120MW and 250 MW are operating in parallel. The governor setting on the machines are such that have 4 percent and 3 percent drops. Determine (i) The load taken by each machine for a total load 200MW.(ii) The percentage no load speed and rated output of machine 1 to made by the speeder motor if the machine are to share a load equally (iii) Rated output of machine 1. (4+4+5)</p>	CO1	6	Create
4	<p>A generating station has the following daily loads :</p> <p>0-6hrs=4500KW; 6-8hrs=3500 KW;        8-12hrs=7500 KW; 12-14hrs=2000 KW;        14-18hrs=8000 KW;8-20hrs=2500 KW;        20-24hrs=5000 KW;</p> <p>Sketch load duration curve and formulate load factor and plant capacity factor, if the capacity of plant is 12 MW. (15)</p>	CO1	6	Create



## UNIT II REAL POWER - FREQUENCY CONTROL

Load Frequency Control (LFC) of single area system-static and dynamic analysis of uncontrolled and controlled cases - LFC of two area system - tie line modeling – block diagram representation of two area system - static and dynamic analysis - tie line with frequency bias control – state variability model - integration of economic dispatch control with LFC.

### PART - A

Q.No	Questions	Course Outcome	BT Level	Competence
1	Quote about coherent group of generators	CO2	1	Remember
2	Distinguish between primary and secondary feedback loops in frequency control	CO2	4	Analyze
3	What is the control area	CO2	2	Understand
4	What are the type load frequency control for interconnected power system	CO2	1	Remember
5	What is the need of integral control single area load frequency control	CO2	4	Analyze
6	What are the assumptions made in dynamic response of uncontrolled case	CO2	1	Remember
7	What is meant by single area power system	CO2	4	Analyze
8	What are the assumptions made in the simplified analysis of the integral control?	CO2	5	Evaluate
9	Specify the use of static and dynamic response of ALFC loop	CO2	2	Understand
10	What is the function of load frequency control	CO2	3	Apply
11	Describe the advantages of multi area operation	CO2	2	Understand
12	Illustrate the advantages of state variable model	CO2	3	Apply
13	Define area control error.	CO2	1	Remember
14	What is the difference of ACE in single-area and two-area power systems	CO2	2	Understand
15	What is the basic principle of pool operation	CO2	1	Remember
16	Draw the block diagram of load frequency control of a two-area control system	CO2	6	Create
17	What is the main difference of load frequency and economic dispatch controls	CO2	3	Apply
18	Quote about AFRC	CO2	1	Remember
19	Explain the principle of tie line bias control.	CO2	4	Analyze
20	What is load frequency control in a two-area power system? Why is it essential to maintain constant frequency in an inter-connected power system?	CO2	6	Create

### PART-B

1	Draw the transfer function block diagram for a single area system provided with static analysis of uncontrolled case and controlled case. (13)	CO2	4	Analyze
2	An isolated power system has the following parameter Turbine rated output=300MW Nominal frequency=50Hz Governor speed regulation=0.05p.u Inertia constant=5 Turbine time constant=0.5 sec Governor time constant=0.2 sec Load change=60MW The load value by 0.8 percent for a 1 percent change in frequency. Determine the steady state frequency deviation in Hz (13)	CO2	6	Create
3	Explain the proportional plus integral control for load frequency control for a single area system. (13)	CO2	3	Apply
4	Discuss in detail the dynamic response of single area system of uncontrolled case and controlled case (13)	CO2	4	Analyze
5	Two generating units having the capacities 600 and 900 MW and are operating at a 50 Hz supply. The system load increases by 150 MW when both the generating units are operating at about half of their capacity, which results in the frequency falling by 0.5 Hz. If the generating units are to share the increased load in proportion to their ratings, what should be the individual speed regulations? What should the regulations be if expressed in p.u. Hz/p.u. MW (13)	CO2	4	Analyze
6	Deduce the expression for steady state frequency change for single area system with the following cases. (i) Changes in load with fixed speed (6) (ii) Changes in speed with fixed demand (7)	CO2	6	Create
7	Estimate the primary ALFC loop parameters for a control area: Total rated area capacity $P_r=2000\text{MW}$ . Normal operating load $P_d=1000\text{MW}$ . Inertia constant $H=5.0$ , Regulation $R=2.40\text{ Hz/p.u MW}$ (all area generators) We shall assume that the load frequency dependency as linear meaning that the old load would increase 1% for 1% .frequency increase. Having the following data. (13)	CO2	5	Evaluate
8	Draw the block diagram of uncontrolled two area load frequency control system and describe the salient features under static condition. (13)	CO2	2	Understand

9	A two area system connected by a tie line has the following parameters with base MVA for each area with the frequency of 50Hz and synchronising power coefficient $T_{12} = 2\text{p.u.}$ . A load change of 400MW occurs in area 1. Determine the steady state frequency deviation and the change in tie line flow (13)	CO2	3	Apply																		
	<table border="1"> <thead> <tr> <th>Area</th> <th>1</th> <th>2</th> </tr> </thead> <tbody> <tr> <td>Turbine output power</td> <td>2000MVA</td> <td>1000MVA</td> </tr> <tr> <td>Inertia constant</td> <td>3%</td> <td>4%</td> </tr> <tr> <td>Generator gain constant</td> <td>50Hz/pu MW</td> <td>40</td> </tr> <tr> <td>Governor time constant</td> <td>0.3</td> <td>0.2</td> </tr> <tr> <td>Turbine time constant</td> <td>0.6</td> <td>0.4</td> </tr> </tbody> </table>				Area	1	2	Turbine output power	2000MVA	1000MVA	Inertia constant	3%	4%	Generator gain constant	50Hz/pu MW	40	Governor time constant	0.3	0.2	Turbine time constant	0.6	0.4
	Area				1	2																
	Turbine output power				2000MVA	1000MVA																
	Inertia constant				3%	4%																
	Generator gain constant				50Hz/pu MW	40																
	Governor time constant				0.3	0.2																
Turbine time constant	0.6	0.4																				
10	Explain with neat block diagram integration of economic dispatch with load frequency control (13)	CO2	2	Understand																		
11	Two areas of a power system network are interconnected by a tie line, whose capacity is 250 MW, operating at a power angle of $45^\circ$ . If each area has a capacity of 2,000 MW and the equal speed-regulation coefficient of 3 Hz/p.u. MW, determine the frequency of oscillation of the power for a step change in load. Assume that both areas have the same inertia constants of $H = 4\text{ s}$ . If a step-load change of 100 MW occurs in one of the areas, determine the change in tie-line power (13)	CO2	3	Apply																		
12	Develop the state variable model of a two area system and state the advantages of the model. (13)	CO2	4	Analyze																		
13	Explain in detail about dynamic analysis uncontrolled case of two area system. (13)	CO2	5	Evaluate																		
14	Explain with neat block diagram tie line with frequency bias control of two area system (13)	CO2	6	Create																		
<b>PART-C</b>																						
1	For an isolated area have the following data: Inertia constant $H=5\text{MWsec/MVA}$ capacity Regulation $R=5\text{Hz/p.u MW}$ Frequency= $50\text{Hz}$ Change in load $\Delta P_D=0.075$ $K_P=100$ $K_I=0.1$ Find the steady state error (15)	CO2	4	Analyze																		

2	<p>A single area consists of two generating units with the following characteristics</p> <table border="1" data-bbox="220 224 960 358"> <thead> <tr> <th>Unit</th> <th>Rating</th> <th>Speed of regulation</th> </tr> </thead> <tbody> <tr> <td>1</td> <td>700MVA</td> <td>7%</td> </tr> <tr> <td>2</td> <td>500MVA</td> <td>4%</td> </tr> </tbody> </table> <p>The units are operating in parallel, sharing 1000MW at the nominal frequency . Unit 1 supply 600MW and unit 2 supplies 400MW at 50Hz, The load is increased by 100 MW.</p> <p>(a) Assume there is no frequency dependent load. Find the steady state frequency deviation at the new generation on each unit (7)</p> <p>The load varies 1.5 percent for every 1 percent change in frequency deviation and the new generating on each unit (8)</p>	Unit	Rating	Speed of regulation	1	700MVA	7%	2	500MVA	4%	CO2	5	Evaluate
Unit	Rating	Speed of regulation											
1	700MVA	7%											
2	500MVA	4%											
3	<p>Two interconnected Area-1 and Area-2 have the capacity of 2,000 and 500 MW, respectively. The incremental regulation and damping torque coefficient for each area on its own base are 0.2 p.u. and 0.8 p.u., respectively. Find the steady-state change in system frequency from a nominal frequency of 50 Hz and the change in steady-state tie-line power following a 750 MW change in the load of Area-1. (15)</p>	CO2	6	Create									
4	<p>The area system connected by a tie line describe the following characteristics :</p> <table data-bbox="220 1232 960 1411"> <thead> <tr> <th><u>Area 1</u></th> <th><u>Area 2</u></th> </tr> </thead> <tbody> <tr> <td>R=0.01 p.u</td> <td>R=0.02 p.u</td> </tr> <tr> <td>D=0.8p.u</td> <td>D=1.0p.u</td> </tr> <tr> <td>Base MVA =500</td> <td>Base MVA =500</td> </tr> </tbody> </table> <p>A load change of 100MW (0.2p.u) occurs in area 1. What is the new steady state frequency, what is the change in tie line flow? Assume both areas were at nominal frequency (60Hz). (15)</p>	<u>Area 1</u>	<u>Area 2</u>	R=0.01 p.u	R=0.02 p.u	D=0.8p.u	D=1.0p.u	Base MVA =500	Base MVA =500	CO2	5	Evaluate	
<u>Area 1</u>	<u>Area 2</u>												
R=0.01 p.u	R=0.02 p.u												
D=0.8p.u	D=1.0p.u												
Base MVA =500	Base MVA =500												

### UNIT III REACTIVE POWER – VOLTAGE CONTROL

Generation and absorption of reactive power - basics of reactive power control – Automatic Voltage Regulator (AVR) – brushless AC excitation system – block diagram representation of AVR loop - static and dynamic analysis – stability compensation – voltage drop in transmission line - methods of reactive power injection - tap changing transformer, SVC (TCR + TSC) and STATCOM for voltage control.

#### PART - A

Q.No	Questions	Course Outcome	BT Level	Competence
1	What is the different types of Static VAR Compensator	CO3	4	Analyze
2	State the advantage of switched capacitors in voltage control	CO3	1	Remember
3	State the main objectives of Reactive power and Voltage control in power systems	CO3	4	Analyze
4	Outline the role of synchronous generators adopted generating and absorption of reactive power	CO3	1	Remember
5	Formulate the need of reactive power control in electrical power transmission lines?	CO3	6	Create
6	Distinguish between load compensation and system compensation.	CO3	2	Understand
7	Point out the formula for surge impedance of transmission system.	CO3	4	Analyze
8	Summarize the methods used for compensating the uncompensated transmission lines?	CO3	2	Understand
9	State reactive power generation.	CO3	2	Understand
10	Write any two applications of synchronous condensers.	CO3	3	Apply
11	Write down the TCSC base reactance value.	CO3	3	Apply
12	Summarize the common advantages of STATCOM?	CO3	2	Understand
13	Give the explanation about reactive power exchange between converter and the ac system.	CO3	1	Remember
14	Define the term Static VAR Compensator.	CO3	1	Remember
15	Explain booster transformer? Where is it used?	CO3	2	Understand
16	Analyze the methods to improve the voltage profile in the power system.	CO3	4	Analyze
17	Distinguish between ON load tap changing transformer and OFF load tap changing transformer.	CO3	4	Analyze
18	Summarize the SVC slope in the dynamic characteristics?	CO3	5	Evaluate
19	Invent importance of V-I characteristics of STATCOM?	CO3	5	Evaluate
20	Develop the V-I characteristics of the SVC.	CO3	6	Create

**PART-B**

1	Examine various methods of voltage control and explain any three in detail. (13)	CO3	1	Remember
2	(i) Name the generators and consumers of reactive power in a power system. (6) (ii) Describe static VAR compensators? Quote the advantages of SVC. (7)	CO3	1,1	Remember
3	Explain the following methods of voltage control (i) Tap changing transformers (ii) Shunt reactors (iii) Synchronous phase modifiers (iv) Shunt capacitors (v) series capacitors. (3+3+3+2+2)	CO3	2	Understand
4	Examine the circuit for a typical excitation system and derive the transfer function model and draw the block diagram. (13)	CO3	3	Apply
5	Describe the different methods of FACTS control? Examine any two methods in detail. (13)	CO3	2	Understand
6	Develop an IEEE Type 1 excitation arrangement to control the voltage of an alternator and explain. (13)	CO3	5	Evaluate
7	Explain with neat diagram and V-I characteristics, the basic operating of TCR and TSC. (13)	CO3	2	Understand
8	(i) Demonstrate in brief about Brushless excitation system. (7) (ii) Point out the relations between voltage, power and reactive power at a node for applications in power system control (6)	CO3	3,4	Apply
9	Analyze various methods of static excitation system and explain any two in detail. (13)	CO3	4	Analyze
10	Discuss static and dynamic analysis of AVR. (13)	CO3	6	Create
11	A 415kV line is fed through an 132/415 kV transformer from a constant 132kV supply. At the load end of the line, the voltage is reduced by another transformer of ratio 415/132 KV. The total impedance of line is $40 + j80$ ohms both transformers are equipped with tap changing; the product of the two off nominal setting is unity. if the load on the system is 200 MW at 0.8 p.f lagging. Calculate the settings of the tap changers required to maintain the voltage at 132KV. (13)	CO3	5	Evaluate
12	Explain in detail, the stability compensation and effects of generator loading. (13)	CO3	5	Evaluate
13	(i). Discuss the events which affect the speed and probability of voltage collapse in power system operating strategy (6) (ii) Explain with neat block diagram the excitation system and its modeling with relevant transfer function (7)	CO3	6	Create

14	(i). A three phase overhead line has resistance and reactance per phase of $5\Omega$ and $25\Omega$ , respectively. The load at the receiving-end is 15 MW, 33kV, 0.8 p.f. lagging. Find the capacity of the compensation equipment needed to deliver this load with a sending-end voltage of 33 kV. (8) (ii) Discuss the generation and absorption of reactive power. (5)	CO3	6	Create
<b>PART-C</b>				
1.	Explain the operation of tap changing transformer and discuss its application. (15)	CO3	5	Evaluate
2.	Develop the block diagram of AVR and obtain its transfer function and explain the static and dynamic response. (15)	CO3	6	Create
3.	The load at the receiving end of a 3 phase OHL is 25 MW at 0.8 p.f lag at a line voltage of 33kv.the line has a resistance 5 ohm per phase and an inductive reactance at 20 ohm per phase .calculate the sending end voltage. A synchronous compensator connected at the receiving end and the voltage at both end of the line is maintained at 33kv.calculate (i)the MVAR of the compensator (ii)transmission losses and efficiency with and without compensator and (iii)the maximum load that can be transmitted with the compensator. (15)	CO3	5	Evaluate
4.	Find the rating of synchronous compensator connected to the tertiary winding of 60kV star connected, 33kV star connected, 11kV delta connected three winding transformer to supply a load of 60MW at 0.8p.f lagging at 33kV across the secondary. Equivalent primary and tertiary winding reactances are $18\Omega$ and $0.12\Omega$ respectively. While the secondary winding reactance is negligible. Assume that $V_1$ is 66kV and maximum off nominal setting between transformer primary and secondary is 1:1.1 (15)	CO3	6	Create

### UNIT IV ECONOMIC OPERATION OF POWER SYSTEM

Statement of economic dispatch problem - input and output characteristics of thermal plant - incremental cost curve - optimal operation of thermal units without and with transmission losses (no derivation of transmission loss coefficients) - base point and participation factors method - statement of unit commitment (UC) problem - constraints on UC problem – solution of UC problem using priority list – special aspects of short term and long term hydrothermal problems.

#### PART - A

Q.No	Questions	Course Outcome	BT Level	Competence
1	Define penalty factor	CO4	BT-2	Understand
2	Show the condition for the optimal power dispatch in lossless system.	CO4	BT-3	Apply
3	Prepare the incremental fuel cost curve	CO4	BT-1	Remember
4	Define spinning reserve?	CO4	BT-1	Remember
5	Explain the significance of Unit Commitment.	CO4	BT-6	Create
6	Explain about FLAC?	CO4	BT-1	Remember
7	List the equality and inequality constraints considered in the economic dispatch problem.	CO4	BT-3	Apply
8	Demonstrate spinning reserve constraint in unit Commitment problem	CO4	BT-2	Understand
9	Differentiate minimum up and minimum down time in unit commitment problem?	CO4	BT-3	Apply
10	Analyze participation factor.	CO4	BT-4	Analyze
11	Interpret participation factor with respect to Economic load dispatch.	CO4	BT-2	Understand
12	Express co-ordination equation taking losses into account.	CO4	BT-2	Understand
13	Define crew constraints.	CO4	BT-3	Apply
14	Differentiate unit commitment and Economic load dispatch	CO4	BT-2	Understand
15	List the few constraints that are accounted in unit commitment problem.	CO4	BT-1	Remember
16	Describe priority list method	CO4	BT-1	Remember
17	What is the need of hydro thermal scheduling	CO4	BT-1	Remember
18	Analysis different methods for solving hydro thermal scheduling	CO4	BT-4	Analyze
19	Define incremental transmission loss.	CO4	BT-5	Evaluate
20	Differentiate between load frequency controller and economic dispatch controller	CO4	BT-4	Analyze

**PART-B**

1	What is meant by unit commitment and explain briefly the constrains on unit commitment (13)	CO4	BT-4	Analyze																
2	The fuel inputs per hour of plants 1 and 2 are given as $F_1 = 0.2P_1^2 + 40P_1 + 120$ Rs/hr $F_2 = 0.25P_2^2 + 30P_2 + 150$ Rs/hr Calculate the economic operating schedule and the corresponding cost of generation. The maximum and the minimum loading on each unit are 100MW and 25MW. Assume the transmission losses are ignored and the total demand is 180MW. Also determine the saving obtained if the load is equally shared by both the units. (13)	CO4	BT-3	Apply																
3	(i) With the help of Flow chart explain Economic dispatch by $\lambda$ Iteration method without loss. (ii) The fuel cost of two units are given by $F_1 = F_1(P_{G1}) = 1.5 + 20P_{G1} + 0.1P_{G1}^2$ Rs/hr $F_2 = F_2(P_{G2}) = 1.9 + 30P_{G2} + 0.1P_{G2}^2$ Rs/hr If the total demand on the generator is 200 MW. calculate the economic load scheduling of the two units. (6+7)	CO4	BT-4, BT-3	Apply Analyze																
4	(i) Describe unit commitment problem? List the constraints that are to be accounted in unit commitment problem. (ii) Give out the priority list of unit commitment using full load average production cost for the given data: Heat rate of unit1 $H_1 = 510 + 7.2P_{G1} + 0.00142 P_{G1}^2$ MW/hr Heat rate of unit2 $H_2 = 310 + 7.85P_{G2} + 0.00194P_{G2}^2$ MW/hr Heat rate of unit3 $H_3 = 78 + 7.97P_{G3} + 0.00482P_{G3}^2$ MW/hr. $P_D = 500$ MW <table border="1" style="margin-left: auto; margin-right: auto;"> <thead> <tr> <th>Unit</th> <th>Min(MW)</th> <th>Max(MW)</th> <th>Fuel cost</th> </tr> </thead> <tbody> <tr> <td align="center">1</td> <td align="center">150</td> <td align="center">600</td> <td align="center">1.1</td> </tr> <tr> <td align="center">2</td> <td align="center">100</td> <td align="center">400</td> <td align="center">1.0</td> </tr> <tr> <td align="center">3</td> <td align="center">50</td> <td align="center">200</td> <td align="center">1.2</td> </tr> </tbody> </table> (6+7)	Unit	Min(MW)	Max(MW)	Fuel cost	1	150	600	1.1	2	100	400	1.0	3	50	200	1.2	CO4	BT-3	Apply
Unit	Min(MW)	Max(MW)	Fuel cost																	
1	150	600	1.1																	
2	100	400	1.0																	
3	50	200	1.2																	
5	The fuel cost functions for three thermal plants in \$/h are given by $F_1 = 0.0045P_{g1}^2 + 5.2P_{g1} + 580$ $F_2 = 0.0056P_{g2}^2 + 4.5P_{g2} + 640$ $F_3 = 0.0079P_{g3}^2 + 5.8P_{g3} + 820$ where $P_{g1}, P_{g2}, P_{g3}$ are in MW. Estimate the optimal dispatch and the total cost when the total load is 925 MW with the following generator limits. $250 \text{ MW} \leq P_{g1} \leq 450 \text{ MW}$ , $200 \text{ MW} \leq P_{g2} \leq 350 \text{ MW}$ , $125 \text{ MW} \leq P_{g3} \leq 250 \text{ MW}$ (13)	CO4	BT-4	Analyze																

6	Explain the mathematical formulation of long-term hydro-thermal scheduling. (13)	CO4	BT-2	Understand
7	<p>(i) Evaluate the priority list for the units given below.</p> $H_1 = 510 + 7.20P_1 + 0.00142P_1^2$ $P_{\min} = 150 \text{ MW}, P_{\max} = 600 \text{ MW}$ <p>Fuel cost = 1.1 Rs/MBtu. <math>H_2 = 310 + 7.85P_2 + 0.00194P_2^2</math></p> $P_{\min} = 100 \text{ MW}, P_{\max} = 400 \text{ MW}$ <p>Fuel cost = 1.0 Rs/MBtu</p> $H_3 = 78 + 7.97P_3 + 0.00482P_3^2$ $P_{\min} = 50 \text{ MW}, P_{\max} = 200 \text{ MW}$ <p>Fuel cost = 1.2 Rs/MBtu</p> <p>ii) With the help of Flow chart explain Economic dispatch by <math>\lambda</math> Iteration method with losses (7+6)</p>	CO4	BT-5	Evaluate
8	<p>The cost characteristics of three plants of a system are</p> $C_1 = 0.05P_1^2 + 17.0P_1 + 160 \text{ Rs/hour}$ $C_2 = 0.06P_2^2 + 14.4P_2 + 200 \text{ Rs/hour}$ $C_3 = 0.08P_3^2 + 9.0P_3 + 240 \text{ Rs/hour}$ <p>Where <math>P_1, P_2, P_3</math> are in MW.</p> <p>The incremental transmission losses for the network with respect to plants 1, 2 and 3 are 0.05, 0.10 and 0.15 MW per MW of generation. Examine the optimal dispatch for a total load of 100MW and also its incremental cost of received power. (13)</p>	CO4	BT-1	Remember
9	<p>The input output curve characteristics of three units are</p> $F_1 = 750 + 6.49P_{g1} + 0.0035P_{g1}^2$ $F_2 = 870 + 5.75P_{g2} + 0.0015P_{g2}^2$ $F_3 = 620 + 8.56P_{g3} + 0.001P_{g3}^2$ <p>The fuel cost of unit 1 is 1.0 Rs/MBtu, 1.0 Rs/MBtu for unit 2 and 1.0 Rs/MBtu for unit 3. Total load is 800MW. Use the participation factor method to Estimate the dispatch for a load is increased to 880MW? (13)</p>	CO4	BT-2	Understand

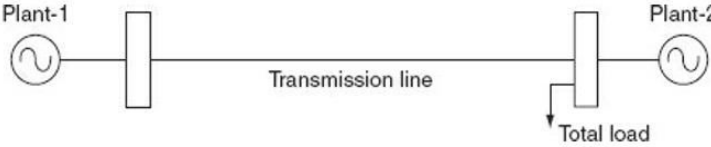
10	<p>A system consists of two power plants connected by a transmission line. The total load located at Plant-2 is as shown in figure. Data of evaluating loss coefficients consist of information that a power transfer of 100 MW from Station-1 to Station-2 results in a total loss of 8 MW. Find the required generation at each station and power received by the load when <math>\lambda</math> of the system in Rs. 100/MWh. The IFCs of the two plants are given by</p> $\frac{dC_1}{dP_{G_1}} = 0.12P_{G_1} + 65 \text{ Rs./MWh}$ $\frac{dC_2}{dP_{G_2}} = 0.25P_{G_2} + 75 \text{ Rs./MWh}$ <p style="text-align: right;">(13)</p> 	CO4	BT-2	Understand																
11	<p>(i) Explain different types of hydro thermal scheduling problem  (ii) Compose the priority list method of solving unit commitment Problem. State merits and limitations of this method. (7+6)</p>	CO4	BT-6	Create																
12	<p>Assume that all three of the thermal units described are running. Find the economic dispatch Schedules as requested in each part. Use the method and starting conditions given.</p> <table border="1" data-bbox="225 1066 1058 1335"> <thead> <tr> <th>Unit Data</th> <th>Minimum Fuel (MW)</th> <th>Maximum Fuel (MW)</th> <th>Cost(Rs/M Btu)</th> </tr> </thead> <tbody> <tr> <td><math>H_1=225+8.4P_1+0.0025P_1^2</math></td> <td>45</td> <td>350</td> <td>0.80</td> </tr> <tr> <td><math>H_2=225+8.4P_2+0.0025P_2^2</math></td> <td>45</td> <td>350</td> <td>1.02</td> </tr> <tr> <td><math>H_3=225+8.4P_3+0.0025P_3^2</math></td> <td>47.5</td> <td>450</td> <td>0.90</td> </tr> </tbody> </table> <p>i. Use Lambda iteration method to find the economic dispatch for a total demand of 450MW  ii. With the solution obtained in (iii), using base point and participation factor find the economic schedule for a demand of 495 MW (4+4+5)</p>	Unit Data	Minimum Fuel (MW)	Maximum Fuel (MW)	Cost(Rs/M Btu)	$H_1=225+8.4P_1+0.0025P_1^2$	45	350	0.80	$H_2=225+8.4P_2+0.0025P_2^2$	45	350	1.02	$H_3=225+8.4P_3+0.0025P_3^2$	47.5	450	0.90	CO4	BT-5	Evaluate
Unit Data	Minimum Fuel (MW)	Maximum Fuel (MW)	Cost(Rs/M Btu)																	
$H_1=225+8.4P_1+0.0025P_1^2$	45	350	0.80																	
$H_2=225+8.4P_2+0.0025P_2^2$	45	350	1.02																	
$H_3=225+8.4P_3+0.0025P_3^2$	47.5	450	0.90																	
13	<p>A plant has two generators supplying the plant by and neither is to be operated below 20MW or above 135MW. Incremental costs with PG1 and PG2 in MW are  <math>dF_1/dP_{G1}=0.14P_{G1}+21 \text{ Rs/MWhr}</math>  <math>dF_2/dP_{G2}=0.225P_{G2}+16.5 \text{ Rs/MWhr}</math>  For economic dispatch, find the plant when the demand equals  (a) 45MW (b) 125 MW (c) 250MW (13)</p>	CO4	BT-6	Create																

14	<p>In a power system having two units, the loss co- efficient are  <math>B_{11}= 0.0015 \text{ MW}^{-1}</math>, <math>B_{12}= -0.0006 \text{ MW}^{-1}</math>,  <math>B_{21}= -0.0006 \text{ MW}^{-1}</math>, <math>B_{22}= 0.0024 \text{ MW}^{-1}</math>  The incremental production cost of the units are  <math>df_1/dpg_1 = 0.08 \text{ pg}_1 + 20 \text{ Rs/ MWhr}</math>  <math>df_2/dpg_2 = 0.09 \text{ pg}_2 + 16 \text{ Rs/ MWhr}</math>  Find the generation schedule for <math>X = 18</math> and <math>22</math>.  find also the change in transmission losses between the two  schedules. (13)</p>	CO4	BT-5	Evaluate
----	---	-----	------	----------

**PART-C**

1	<p>What is short term hydro-thermal scheduling? What is the objective function and constraints of short term hydrothermal scheduling? Explain in detail (15)</p>	CO4	BT-5	Evaluate
---	--	-----	------	----------

2	<p>Four units to be committed to serve 1 hr load pattern. Find the optimum unit commitment. Use forward dynamic programming method. Fuel cost of each unit is 2.15 Rs/MBtu. (15)</p> <table border="1" style="margin-left: 20px;"> <thead> <tr> <th>UNIT</th> <th>Max (MW)</th> <th>Min (MW)</th> <th>Inc. heat rate(Btu/Kwh)</th> <th>No load cost Rs/h</th> <th>Start Up cost Rs</th> <th>Inc Cost Rs/Mw h</th> </tr> </thead> <tbody> <tr> <td>1</td> <td>80</td> <td>25</td> <td>10440</td> <td>213</td> <td>350</td> <td>20.88</td> </tr> <tr> <td>2</td> <td>250</td> <td>60</td> <td>9000</td> <td>585.62</td> <td>400</td> <td>18</td> </tr> <tr> <td>3</td> <td>300</td> <td>75</td> <td>8730</td> <td>684.74</td> <td>-</td> <td>17.46</td> </tr> <tr> <td>4</td> <td>60</td> <td>20</td> <td>11900</td> <td>252</td> <td>0</td> <td>23.8</td> </tr> </tbody> </table> <p>Load pattern</p> <table border="1" style="margin-left: 20px;"> <thead> <tr> <th>Period</th> <th>1</th> <th>2</th> </tr> </thead> <tbody> <tr> <td>Load(MW)</td> <td>450</td> <td>600</td> </tr> </tbody> </table>	UNIT	Max (MW)	Min (MW)	Inc. heat rate(Btu/Kwh)	No load cost Rs/h	Start Up cost Rs	Inc Cost Rs/Mw h	1	80	25	10440	213	350	20.88	2	250	60	9000	585.62	400	18	3	300	75	8730	684.74	-	17.46	4	60	20	11900	252	0	23.8	Period	1	2	Load(MW)	450	600	CO4	BT-6	Create
UNIT	Max (MW)	Min (MW)	Inc. heat rate(Btu/Kwh)	No load cost Rs/h	Start Up cost Rs	Inc Cost Rs/Mw h																																							
1	80	25	10440	213	350	20.88																																							
2	250	60	9000	585.62	400	18																																							
3	300	75	8730	684.74	-	17.46																																							
4	60	20	11900	252	0	23.8																																							
Period	1	2																																											
Load(MW)	450	600																																											

3	<p>A two-plant system having a steam plant near the load center and a hydro-plant at a remote location is shown in figure. The load is 500 MW for 16 hr a day and 350-MW, for 8 hr a day. The characteristics of the units are  <math>C_1 = 120 + 45 P_{GT} + 0.075 P_{GT}^2</math>  <math>w_2 = 0.6 P_{GH} + 0.00283 P_{GH}^2 \text{ m}^3/\text{s}</math>  Loss coefficient, <math>B_{22} = 0.001 \text{ MW}^{-1}</math> Find the generation schedule, daily water used by the hydro-plant, and daily operating cost of the thermal plant for <math>\gamma^j = 85.5 \text{ Rs./m}^3\text{-hr}</math>. (15)</p> 	CO4	BT-5	Evaluate
---	--	-----	------	----------

4	<p>Analyse the coordination equation for economic dispatch including losses and give the steps for economic dispatch calculation, neglecting losses. (15)</p>	CO4	BT-6	Create
---	---	-----	------	--------

## UNIT V -COMPUTER CONTROL OF POWER SYSTEMS

Need of computer control of power systems-concept of energy control centers and functions – PMU - system monitoring, data acquisition and controls - System hardware configurations - SCADA and EMS functions - state estimation problem – measurements and errors - weighted least square estimation - various operating states - state transition diagram.

### PART - A

Q.No	Questions	Course Outco	BT Level	Competence
1	What are the advantages of computer control	CO5	BTL-1	Remember
2	Define state estimation.	CO5	BTL-2	Understand
3	Define restorative state.	CO5	BTL-1	Remember
4	Quote any two functions of Load Dispatch Centre.	CO5	BTL-2	Understand
5	What is meant by PMU	CO5	BTL-1	Remember
6	List the different operating states in power system.	CO5	BTL-1	Remember
7	Distinguish between reliability and security of power system.	CO5	BTL-1	Remember
8	Explain the EMS functions?	CO5	BTL-2	Understand
9	Mention four types of SCADA system and its application area	CO5	BTL-4	Analyze
10	Explain what do you understand by security control.	CO5	BTL-1	Understand
11	What are the methods to find bad data during measuring	CO5	BTL-4	Analyze
12	Give out functions of SCADA	CO5	BTL-4	Analyze
13	Illustrate the typical sensors used in power system application	CO5	BTL-1	Remember
14	Define weighted least square criterion.	CO5	BTL-3	Apply
15	Compare load flow and state estimation	CO5	BTL-5	Evaluate
16	What are the applications of state estimation	CO5	BTL-5	Evaluate
17	Explain the hierarchical levels used in EMS.	CO5	BTL-3	Apply
18	Point out the importance of state estimation in power system.	CO5	BTL-3	Apply
19	What is meant by maximum likelihood criterion	CO5	BTL-6	Create
20	Prepare the functions of load control centre?	CO5	BTL-6	Create
<b>PART-B</b>				
1	Discuss various functions of SCADA with neat diagram. Also list some of the common features (13)	CO5	BTL-1	Remember
2	Discuss the various functions, system monitoring and control of load dispatch centre. (13)	CO5	BTL-1	Remember

3	Explain in detail phasor measurement unit in computer control of power system (13)	CO5	BTL-5	Evaluate
4	Explain the security monitoring using state estimation with necessary diagrams . (13)	CO5	BTL-1	Remember
5	(i) Prepare need of computer control of power system. (6) (ii) Evaluate the major functions of system security control. (7)	CO5	BTL-6	Create
6	Explain in detail different methods of measurement scheme to identify bad data for reduction measurement error. (13)	CO5	BTL-5	Evaluate
7	Illustrate the various functions of energy control centre. (13)	CO5	BTL-2	Understand
8	Explain the need of computer control of power system (13)	CO5	BTL-2	Understand
9	Infer short notes on energy control centre EMS and its functions. (13)	CO5	BTL-5	Evaluate
10	Explain the power system security and control with neat flow chart. (13)	CO5	BTL-3	Apply
11	Draw a state transition diagram of a power system showing different sets of operating states classified according to security level. Mark on the diagram and explain the state transition that may occur due to system disturbances and also the different control action that can be taken to improve the security level of the system. (13)	CO5	BTL-2	Understand
12	What is EMS? Explain in detail major functions in power system operation and control? (13)	CO5	BTL-3	Apply
13	Explain in detail the state estimation of power system using WLSE method (13)	CO5	BTL-4	Analyze
14	Explain the substation control function arranged through SCADA system. (13)	CO5	BTL-5	Evaluate
<b>PART-C</b>				
1	Discuss briefly how the system states are continuously monitored and controlled. (15)	CO5	BTL 4	Analyze
2	Write short notes on state estimation? Explain the help of flow chart the weighted least square estimation. (15)	CO5	BTL 6	create
3	Explain in detail, the system hardware employed to control the power system operation. (15)	CO5	BTL 5	Evaluate

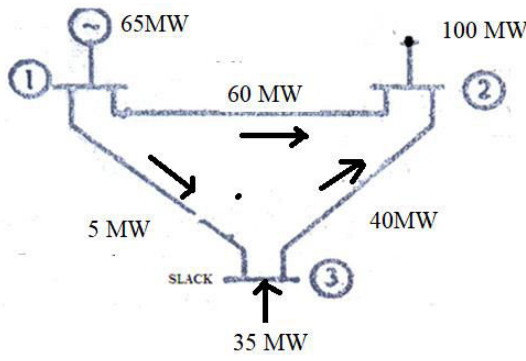
4	 <p>Determine the state vectors, line flow and power injections at the buses using state estimation for the given measurements for the figure  Take 100MVA base, <math>X_{12}=0.2</math>, <math>X_{13}=0.4</math>, <math>X_{23}=0.25</math>  Without errors measurements are <math>M_{13}=5\text{MW}</math>, <math>M_{32}=40\text{MW}</math>  With errors, measurement are <math>M_{12}=62\text{MW}</math>, <math>M_{13}=6\text{MW}</math>,  <math>M_{32}=37\text{MW}</math> (15)</p>		BTL 6	Create
---	--	--	-------	--------

