

SRM VALLIAMMAI ENGINEERING COLLEGE

(An Autonomous Institution)

SRM Nagar, Kattankulathur – 603 203

DEPARTMENT OF MECHANICAL ENGINEERING



VI SEMESTER

1909609 CAD /CAM AND ANALYSIS LABORATORY MANUAL

Regulation – 2019

Academic Year 2022 -2023 (Even Semester)

Prepared by

Mr.R.Ashok, Assistant Professor /MECH

OBJECTIVES:

The main learning objective of this course is to provide hands on training to the students in to:

- Design three dimensional (3D) geometric model of parts, sub-assemblies, assemblies and exporting it to drawing.
- Analyze the force, stress, deflection in mechanical components.
- Analyze thermal stress and heat transfer in mechanical components.
- Analyze the vibration of mechanical components.
- Apply the fundamental working principle of CNC machine tool, Programming G & M Code programming and simulate the CNC program.

LIST OF EXPERIMENTS:**1. 3D GEOMETRIC MODELLING****20**

1. CAD Introduction – Sketcher
2. Solid modelling: Extrude, Revolve, Sweep, Variational sweep and Loft.
3. Surface modelling: Extrude, Sweep, Trim, Mesh of curves and Free form.
4. Feature manipulation: Copy, Edit, Pattern, Suppress, History operations.
5. Assembly: Constraints, Exploded Views, Interference check
6. Drafting: Layouts, Standard & Sectional Views, Detailing & Plotting.
7. Exercises in Modelling and drafting of Mechanical Components
8. Assembly using Parametric and Feature based Packages

2. SIMULATION AND ANALYSIS**20**

1. Force and Stress analysis using link elements in Trusses.
2. Stress and deflection analysis in beams with different support conditions.
3. Stress analysis of flat plates.
4. Stress analysis of axis-symmetric components.
5. Thermal stress and heat transfer analysis of plates.
6. Thermal stress analysis of cylindrical shells.
7. Vibration analysis of spring-mass systems.

3. MANUAL PART PROGRAMMING: - CNC Machining and Turning Centre

20

1. Linear Cutting.
2. Circular cutting.
3. Cutter Radius Compensation.
4. Canned Cycle Operations.
5. Straight, Taper and Radial Turning.
6. Thread Cutting.
7. Rough and Finish Turning Cycle.
8. Drilling and Tapping Cycle

TOTAL: 60 PERIODS

COURSE OUTCOMES:

Upon completion of this course, the students will be able to:

- Create and export 3 Dimensional geometric models of parts, sub-assemblies, assemblies as a drawing file.
- Examine methodically in detail the force, stress, deflection in mechanical components and understand it.
- Study, understand and interpret about thermal stress and heat transfer in mechanical components.
- Identify and measure the parameters in detail related to the vibration of mechanical components.
- Recognize the fundamental working principle of CNC machine tool, create G & M code program based on application required and simulate the CNC program.

LIST OF EQUIPMENT FOR A BATCH OF 30 STUDENTS

Sl. No.	DESCRIPTION EQUIPMENT	QUANTITY
HARDWARE		
1.	Computer server	1
2.	Computer nodes or systems (High end CPU with atleast 1 GB main memory) networked to the server	30

3.	A3 size plotter / Laser Printer	1
4.	CNC Lathe	1
5.	CNC Milling Machine	1
SOFTWARE		
6.	Any High end integrated modelling and manufacturing CAD / CAM software	15 licenses
7.	CAM Software for machining centre and turning centre - (CNC Programming and tool path simulation for FANUC / Sinumeric and Heidenhain controller)	15 licenses
8.	Licensed operating system	Adequate

co	PO												PSO			
	1	2	3	4	5	6	7	8	9	10	11	12	1	2	3	4
1	2	2			3			1				1				
2	2	2			3			1				1				
3	2	2			3			1				1				
4	2	2			3			1				1				
5	2	3	3		3		2					1	3	2	3	2

INDEX

3D GEOMETRIC MODELLING

SL.NO	DATE	NAME OF THE EXERCISE	PAGE NO.
3D GEOMETRIC MODELLING			
1		CAD INTRODUCTION – SKETCHER	16
2		SOLID MODELLING, SURFACE MODELLING AND FEATURE MANIPULATION	20
3		ASSEMBLY AND DRAFTING	23
EXERCISES IN MODELLING AND DRAFTING OF MECHANICAL COMPONENTS			
4		UNIVERSAL COUPLING	26
5		FLANGE COUPLING	29
SIMULATION AND ANALYSIS			
6		FORCE AND STRESS ANALYSIS USING LINK ELEMENTS IN TRUSSES.	33
7		STRESS AND DEFLECTION ANALYSIS IN BEAMS WITH DIFFERENT SUPPORT CONDITIONS.	35
8		STRESS ANALYSIS OF FLAT PLATES.	37
9		STRESS ANALYSIS OF AXIS-SYMMETRIC COMPONENTS.	39
10		THERMAL STRESS AND HEAT TRANSFER ANALYSIS OF PLATES.	41
11		THERMAL STRESS ANALYSIS OF CYLINDRICAL SHELLS.	43
12		VIBRATION ANALYSIS OF SPRING-MASS SYSTEMS.	45

MANUAL PART PROGRAMMING: - CNC Machining and Turning Centre			
13		SIMPLE TURNING	55
14		STEP TURNING (CANNED CYCLE)	57
15		PROFILE TURNING	59
16		TAPER TUNING	61
17		THREAD CUTTING	63
18		LINEAR AND CIRCULAR INTERPOLATION	65
19		CIRCULAR INTERPOLATION CCW	67
20		CIRCULAR INTERPOLATION CW	69
21		LINEAR INTERPOLATION	71
22		MILLING CIRCLE	73
23		G CODES	74
24		M CODES	76

Introduction to Pro/E - CREO

CREO 2.0 Interface

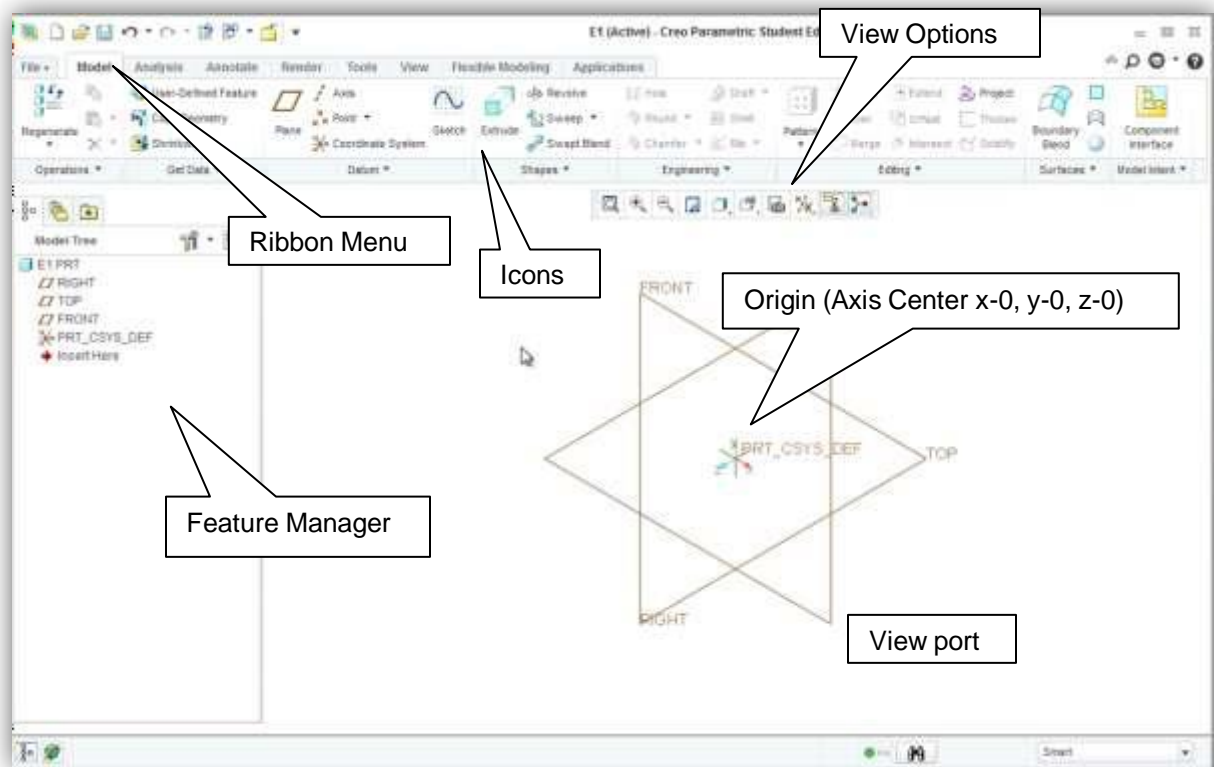

Mouse Buttons

Left Button - Most commonly used for **selecting** objects on the screen or sketching.

Right Button – Used for activating pop-up **menu** items, typically used when editing.
(Note: you must hold the down button for 2 seconds)

Center Button – (option) Used for model **rotation**, **dimensioning**, **zoom** when holding Ctrl key, and **pan** when holding Shift key. It also **cancel**s commands and line chains.

Center Scroll Wheel – (option) same as Center Button when depressed, only it activates **Zoom** feature when scrolling wheel.

“Options & Properties” menus “The heart of CREO”

Selecting the “File” – “Options” pull down menu (located at the top left side of the screen) opens the active documents Options.

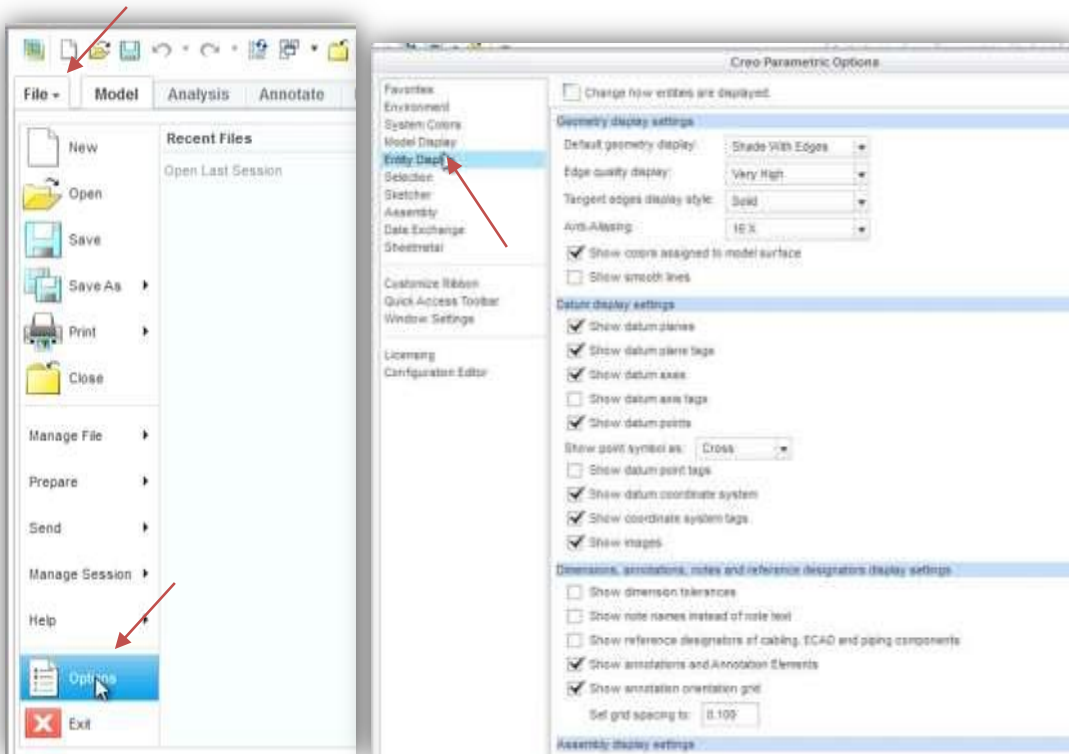

Model Properties

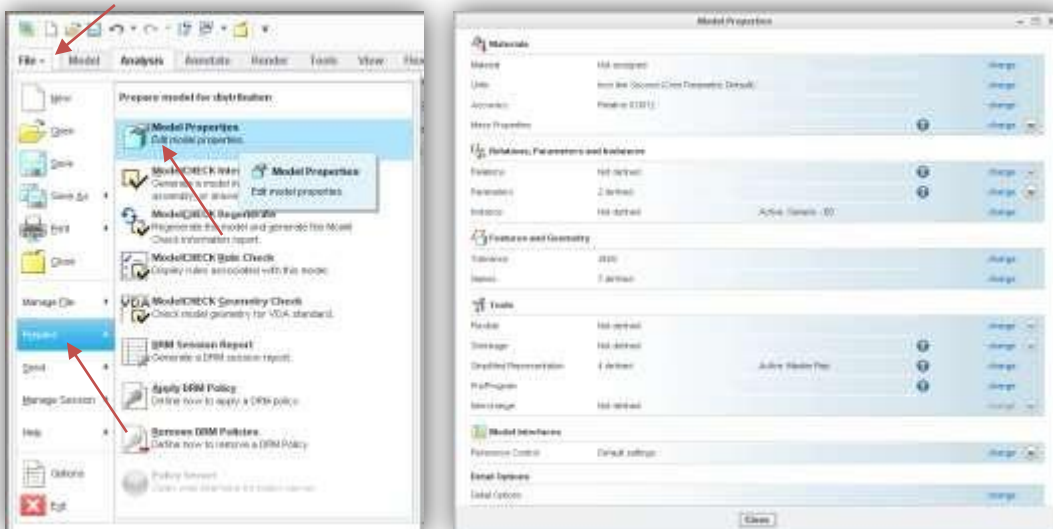

View options

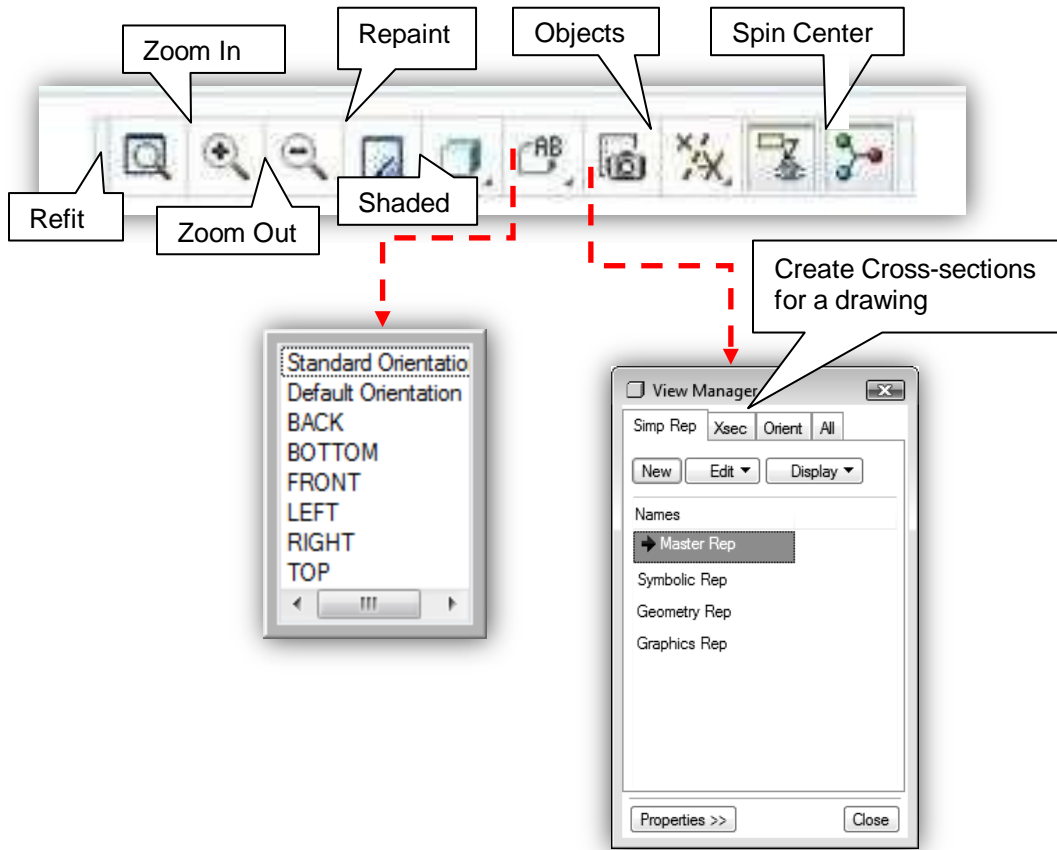

Sketching

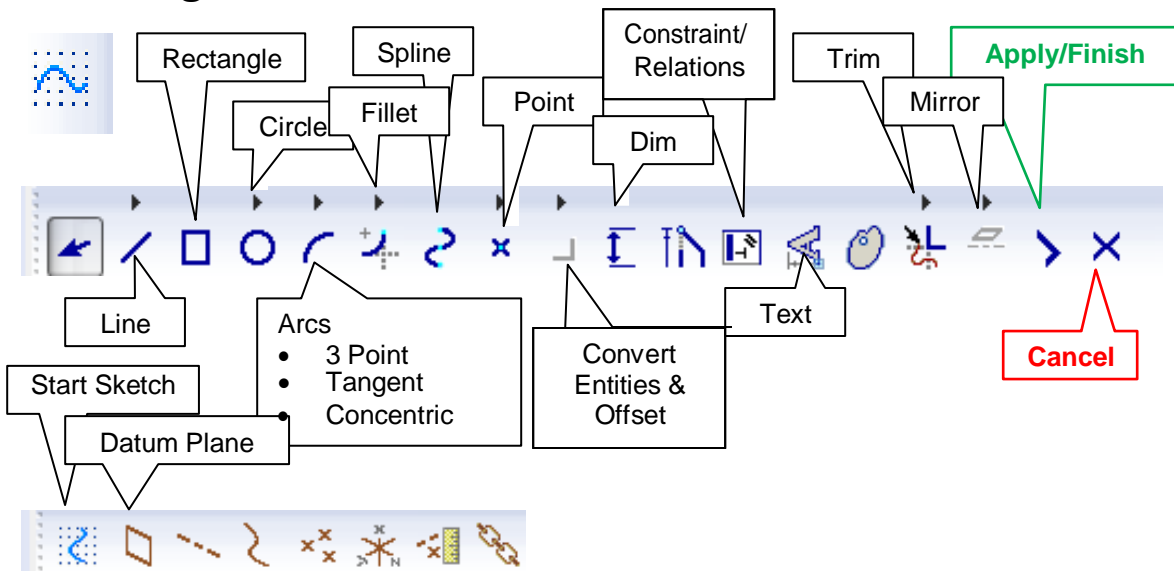

NOTE: If you do not see all of these icons on your interface you can customize the toolbars to bring them up. Right mouse button click on the top grey frame of the window and locate the "customize" option.

Where do you start a sketch?

Sketches can be created on any Datum Plane or Planar Face or Surface. Pro/E provides you with three datum planes centralized at the **Origin** (your zero mark in space)

*NOTE: Planes can also be created and will be discussed in more detail in the future. Also after completing a sketch always select the **Apply/Finish** check mark on the sketch toolbar, this will activate the extrude or revolve feature tools.*

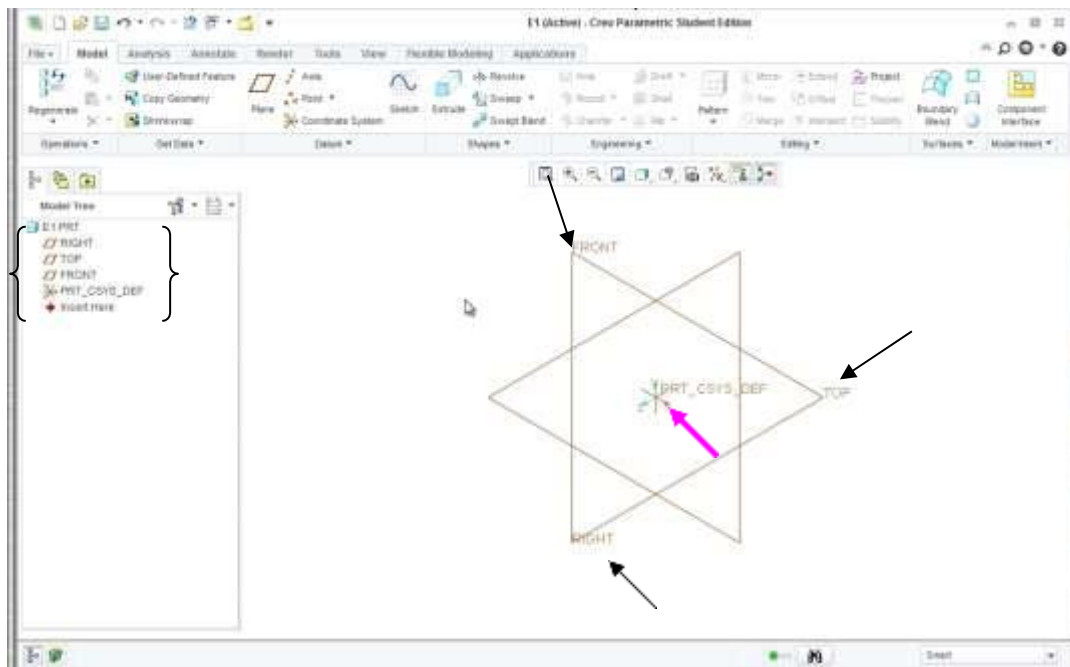

To start a sketch Pre-select the plane or face you desire to sketch on and then select the Sketch Icon.



NOTE: You can select the planes from the "Feature Manager".

Sketch Options –

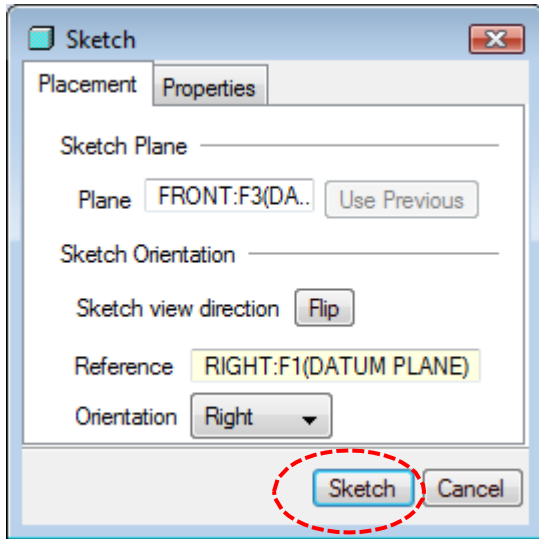

Controlling your geometry...

Pro/E uses two methods for constraining geometric entities.

Constraints and Dimensions

Constraints can be referred to as common elements of geometry such as Tangency, Parallelism, and Concentricity. These elements can be added to geometric entities automatically or manually during the design process.

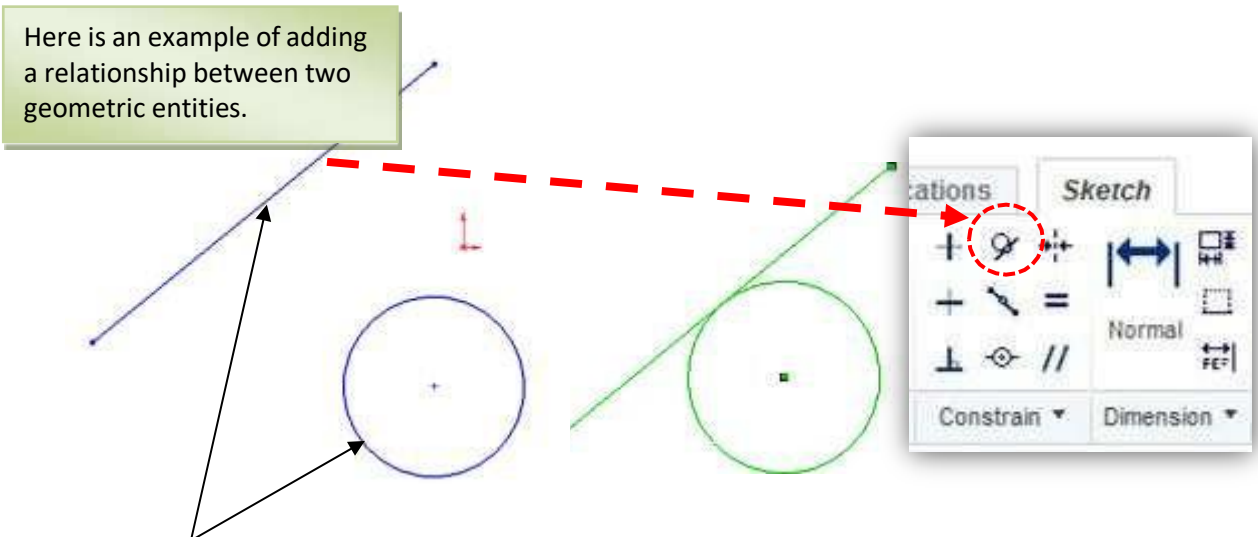

Cautious sketching can save time.

There are 3 primary file types in Creo, which include...

1. **Part** (.prt)
Single part or volume.
2. **Assembly** (.asm)
Multiple parts in one file assembled.
3. **Drawing** (.drw)
The 2D layout containing views, dimensions, and annotations.

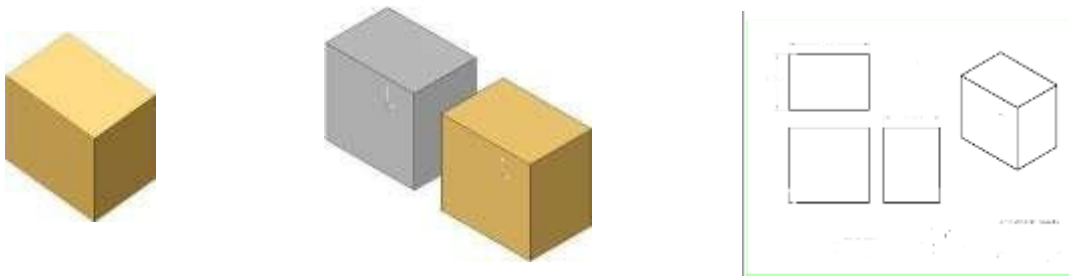

Switching between documents (Activating a document)

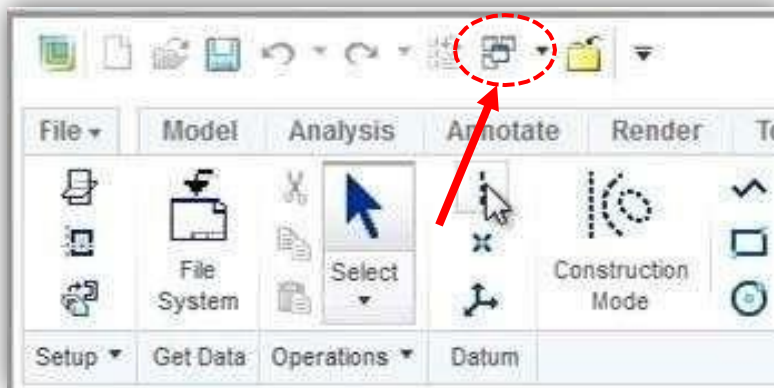

Select the Window pull-down menu and you will see the available documents. Click on the document you wish to work on from the list to “activate” it.

Sketch Constraints (Relations)

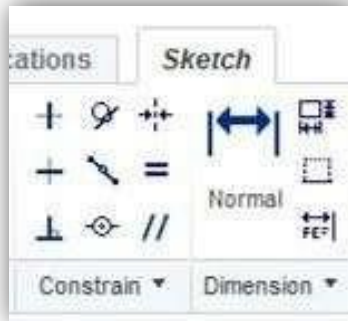

Constraint	Geometric entities to select	Resulting Constraint
Horizontal or Vertical	One or more lines or two or more points.	The lines become horizontal or vertical (as defined by the current sketch space). Points are aligned horizontally or vertically.
Collinear	Two or more lines.	The items lie on the same infinite line.
Perpendicular	Two lines.	The two items are perpendicular to each other.
Parallel	Two or more lines. A line and a plane (or a planar face) in a 3D sketch.	The items are parallel to each other. The line is parallel to the selected plane.
Tangent	An arc, ellipse, or spline, and a line or arc.	The two items remain tangent.
Concentric	Two or more arcs, or a point and an arc.	The arcs share the same centerpoint.
Midpoint	Two lines or a point and a line.	The point remains at the midpoint of the line.
Coincident	A point and a line, arc, or ellipse.	The point lies on the line, arc, or ellipse.
Equal	Two or more lines or two or more arcs.	The line lengths or radii remain equal.
Symmetric	A centerline and two points, lines, arcs, or ellipses.	The items remain equidistant from the centerline, on a line perpendicular to the centerline.

Controlling your geometry with dimensions...

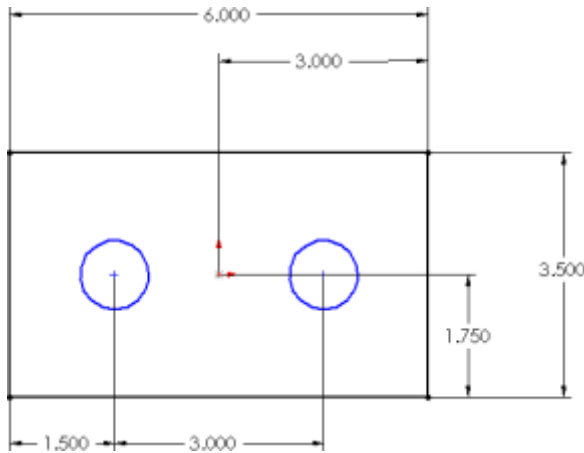

Dimensioning this way will enable the length of the bracket to change but the holes will always remain positioned to the left side.

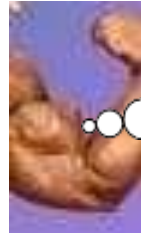

Strong versus **Weak** Dimensions - Double click and change to make them Strong!

Dimensioning this way will enable the length of the bracket to change but the holes will always remain positioned to 1.5" off each

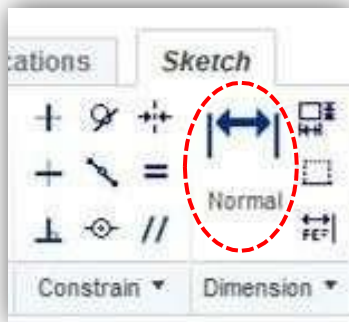
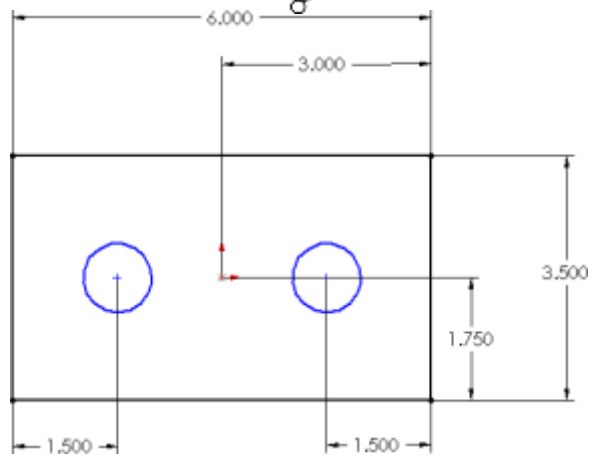

Solid Modeling Basics

Layer Cake method



Extruded Boss/Base (Creates/Adds material)

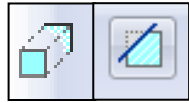

Extruded Cut (Removes material)

Ingredients:

- Profile

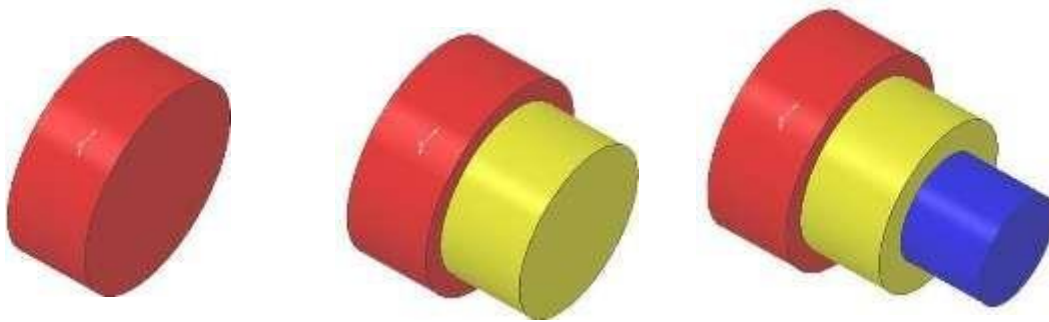

Revolve method



Revolve Boss/Base (Creates/Adds material)

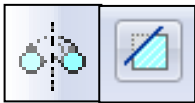

Revolve Cut (Removes material)

Ingredients:

- Profile
- Center Line (Note: The profile cannot cross over the center line!)

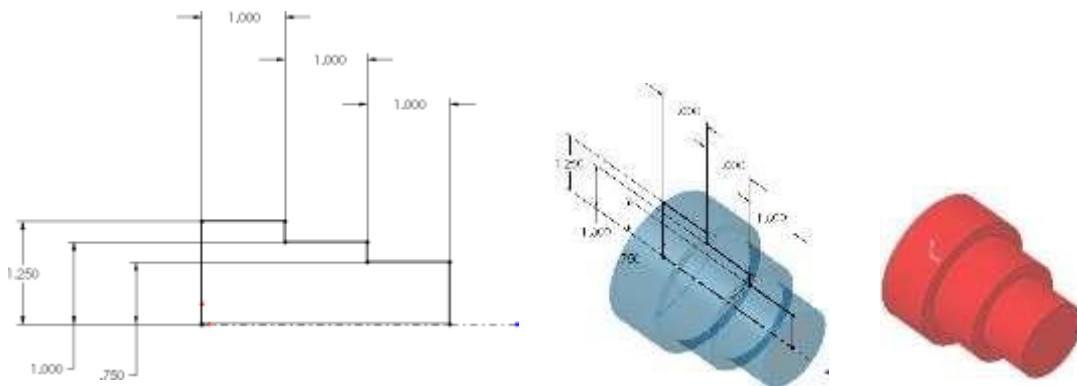

1. CAD Introduction – Sketcher

AIM

To make the sketch for Plummer block in sketcher plane.

HARDWARE REQUIRED

1. CPU with Pentium IV processor.
2. A color monitor with highest 32 bit color display and with screen resolution 1024 by 768 pixels.
3. A scroll mouse.

SOFTWARE REQUIRED

1. Windows 7 operating system
2. PRO-E / Creo

PROCEDURE

1. Identify various parts to be created.
2. First enter into part environment and create the main part.
3. Select the sketch tool and then select the coincidental plane option and select any one of the standard 3 planes (i.e. front, right & top).
4. Create the cross-section profile as a closed one using the 2D commands available after completing the sketch, click open or return button and then click finish button.
5. Save the Part drawing.

RESULT

Thus the sketcher window is used to make the initial sketch for Plummer block.

VIVA-VOCE QUESTIONS

1. What is a Plummer block?
A pillow block bearing (or plumber block) is a pedestal used to provide support for a rotating shaft with the help of compatible bearings & various accessories.
2. What is use of protected type flange coupling?
In this coupling, each flange is provided with a projection. This projection covers the boltheads and nuts so that they do not catch the fingers or the clothes of workmen.
3. List out some of the modeling software currently available?
Solid works, CATIA, Pro-E, IDEAS
4. What is universal coupling?
A universal joint, universal coupling, U-joint, Cardan joint, Hardy-Spicer joint, or Hooke's joint is a joint or coupling in a rigid rod that allows the rod to 'bend' in any direction, and is commonly used in shafts that transmit rotary motion.
5. What are the parts of universal coupling?
It consists of a pair of hinges located close together, oriented at 90° to each other, connected by across shaft.
6. What is coupling?
A coupling is a device used to connect two shafts together at their ends for the purpose of transmitting power. Couplings do not normally allow disconnection of shafts during operation, however there are torque limiting couplings which can slip or disconnect when some torque limitis exceeded.
7. What are the types of couplings?
 1. Rigid Couplings
 2. Flexible or Compensating Couplings
8. What is knuckle joint?
A knuckle joint is used to connect the two rods which are under the tensile load, when there is requirement of small amount of flexibility or angular moment is necessary. There is always axialor linear line of action of load
9. What are the applications of knuckle joint?
Knuckle joint has it applications in the rods for roof, chain link, steam engine valve rod, eccentric rods etc.
10. What is a screw jack?
Screw jack is a mechanical device that can increase the magnitude of an effort force.

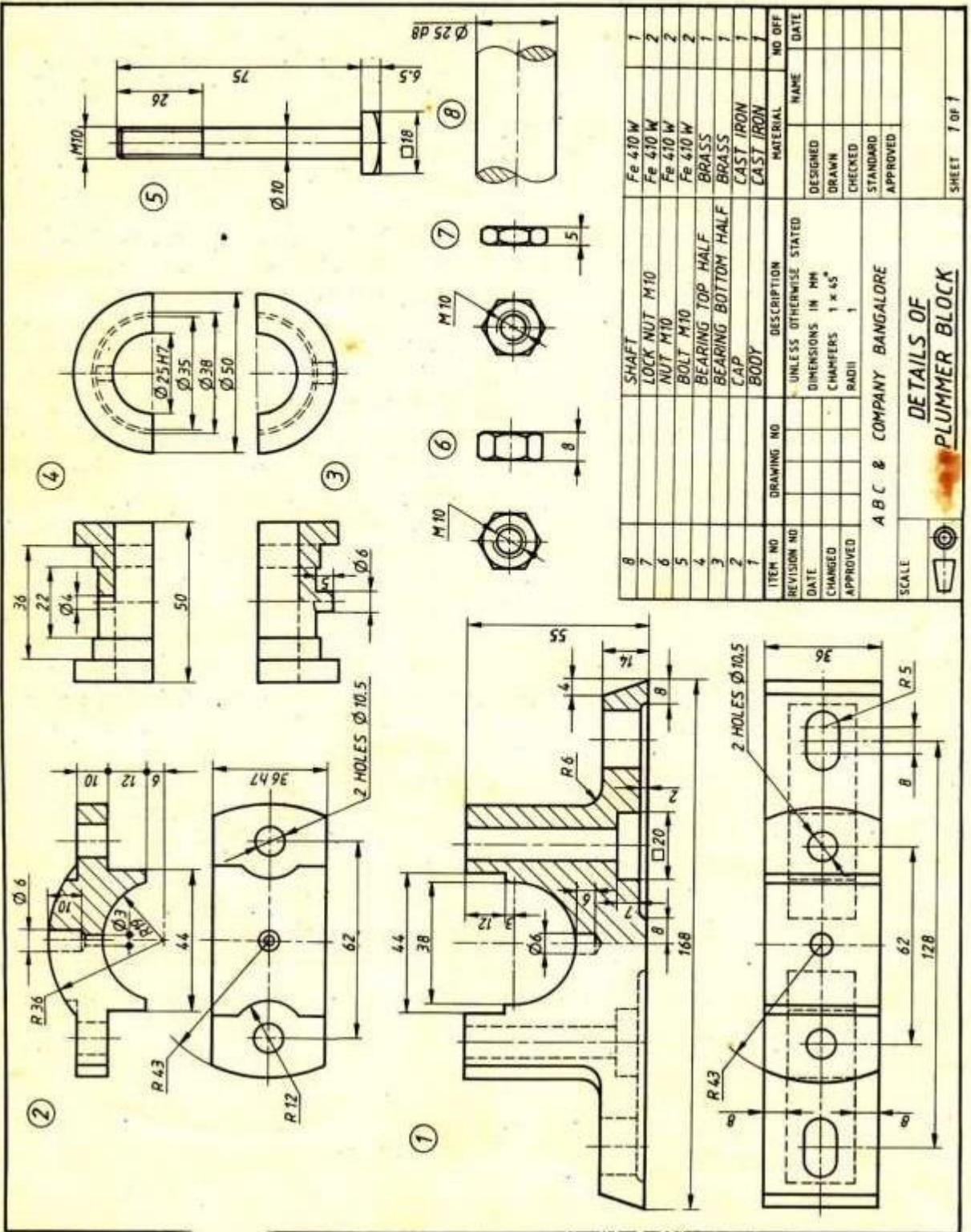

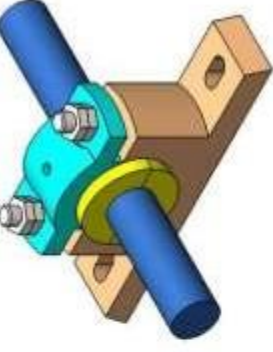

1) Base body

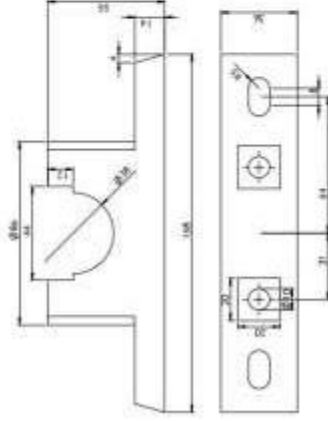

2) CAP

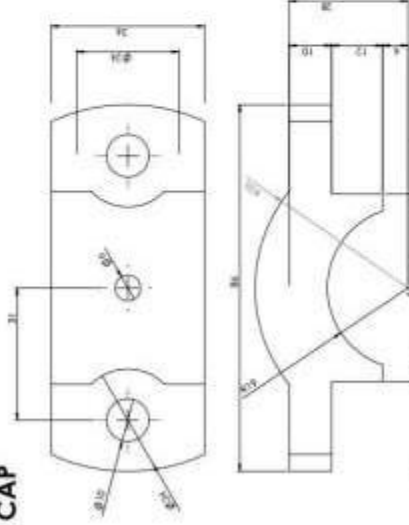

3) Bearing Half

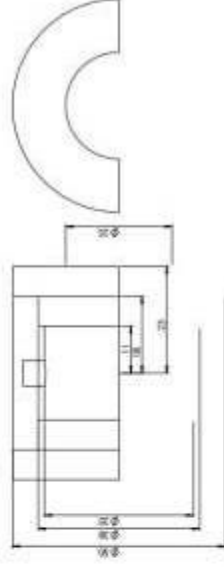

Plummer block
1182 Designing

2. Solid modelling, Surface modelling and Feature Manipulation

AIM

To create the solid model parts of Plummer block with different features.

HARDWARE REQUIRED

1. CPU with Pentium IV processor.
2. A color monitor with highest 32 bit color display and with screen resolution 1024 by 768 pixels.
3. A scroll mouse.

SOFTWARE REQUIRED

1. Windows 7 operating system
2. PRO-E / Creo

PROCEDURE

1. Identify various solid parts to be created from the sketch.
2. Extrude the required thickness from the sketches.
3. Construct the full cross section for portion and construct the half of the cross section and an axis line for revolution.
4. Do the protrusions by using protrusion command and the revolution by revolved protrusion command.
5. For constructing holes and cutout, used hole command and cutout command.
6. If we use hole command, change the diameter of the hole by using modify menu, resize hole option.

RESULT

Thus the sketcher window is used to make the solid model parts for Plummer block.

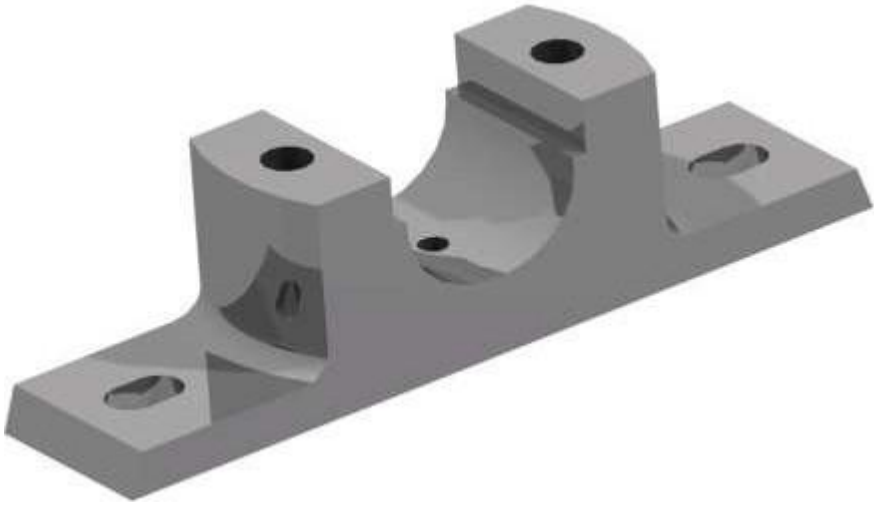

BODY



CAP

VIVA-VOCE QUESTIONS

1. What are the applications of CAD?

- _ Design of machine elements, CNC machine tools, robotics etc
- _ Panel design and circuit layout
- _ Mapping ,building plans, contour plotting and structural drawing
- _ Interior design and modeling

2. Define absolute co-ordinates?

Values locating a point in space that describe its displacement from origin (0,0,0)point of the drawing.

3. Define polar co ordinates.

Values are locating a point in space that describes its location relative to the last point picked as defined by an angle and distance.

4. Define angular dimension?

A dimension that measures the angle between two lines or the angle inscribed by an arc Segment

5. Define aligned dimension?

A linear dimension measuring the distance between two points. The dimension line for an aligned dimension is parallel to a line between points.

6. Define MIRROR?

A command that makes a copy of selected objects and flips the copy around a specified line to produce a reciprocal image of those objects.

7. What are the advantages of CAD?

Greater productivity of the designer, improvement of design quality
Easier design, calculation and analysis, quicker rate producing drawings, more accuracy of drawings, colour graphics is possible

8. What is the default position of the UCS icon?

0,0,0

9. How can you create a cylinder by drawing a rectangular shape

By revolving the rectangular shape

10. Which information does the MASSPROP shortcut provide

Mass, Volume and Bounding box

3.Assembly and Drafting

AIM

To make the assembly for Plummer block and also Sectional views.

HARDWARE REQUIRED

1. CPU with Pentium IV processor.
2. A color monitor with highest 32 bit color display and with screen resolution 1024 by 768 pixels.
3. A scroll mouse.

SOFTWARE REQUIRED

1. Windows 7 operating system
2. PRO-E / Creo

PROCEDURE

1. Load all the sub components.
2. Create the cross-section profile as a closed one using the 2D commands available after completing the sketch, click open or return button and then click finish button.
3. For creating other parts, select sketch both parallel plane option or plane by 3points option and then select the required plane.
4. Construct the full cross section for portion and construct the half of the cross section and an axis line for revolution.
5. Assembly the various parts construct parts construct using the various assembly constrains available (planer, design, mate, axial align, connect etc).
6. After finishing assembly, check whether the various parts have been connected properly or not by rotating the view.
7. Save the assembly.

RESULT

Thus the 3D assembly of the plumber block has been created on the software Creo with accurate dimension and with all respects.

VIVA-VOCE QUESTIONS

1. Where dimension text is generally placed?

Above the dimension line

2. Which dimension tool will place the length of an angled line?

Aligned

3. Which tolerance identify the maximum and minimum sizes of a feature

?Limits

4. A typical set of mechanical working drawings includes

,Exploded assembly, part details and parts list

5. Which primary unit of measurement is used for engineering drawings and design in the mechanical industries?

Millimeter

6. What are the two main types of Projection?

Perspective and Parallel

7. What is flange coupling?

This is a standard form of coupling. It consists of two cast iron flanges keyed to the end of shafts. The flanges are tightened together by means of a number of bolts

8. What is use of protected type flange coupling?

In this coupling, each flange is provided with a projection. This projection covers the bolt heads and nuts so that they do not catch the fingers or the clothes of workmen.

4.UNIVERSAL COUPLING

AIM

To create the universal coupling assembly as a 3D solid model.

HARDWARE REQUIRED

1. CPU with Pentium IV processor.
2. A color monitor with highest 32 bit color display and with screen resolution 1024 by 768 pixels.
3. A scroll mouse.

SOFTWARE REQUIRED

1. Windows 7 operating system
2. PRO-E / Creo

PROCEDURE

1. Identify various parts to be created.
2. First enter into part environment and create the main part and create the main part of the assembly.
3. First identify whether the main part or the first to be created by protrusion or by revolution.
4. Select the sketch tool and then select the coincidental plane option and select any one of the standard 3 planes (i.e. front, right & top).
5. Create the cross-section profile as a closed one using the 2D commands available after completing the sketch, click open or return button and then click finish button.
6. For creating other parts, select sketch both parallel plane option or plane by 3 points option and then select the required plane.
7. Construct the full cross section for portion and construct the half of the cross section and an axis line for revolution.
8. Do the protrusions by using protrusion command and the revolution by revolved protrusion command.
9. For constructing holes and cutout, used hole command and cutout command.
10. If we use hole command, change the diameter of the hole by using modify menu, resize hole option.

Exercise

Details of a UNIVERSAL COUPLING as shown in Fig. 16.30. Draw the following views of the coupling showing all the parts assembled. The two shafts and the keys are not shown in the figure. The shafts are fitted with a push fit of **js7** tolerance. The tolerance for width of key way in the shafts for light drive fit is **N9**. Two parallel keys of 12 x 8 x 63 are used to connect the two shafts. The tolerance for keys are **h9** for width and **h11** for thickness. Indicate the actual tolerances on the dimensions.

1. Front view in half section.
2. Right view.
3. Top view in half section.

16.5.3 Universal Coupling

Another type of universal coupling is shown in Fig. 16.31, its various detailed components are shown separately in Fig. 16.32. It consists of two forks keyed to the ends of the two shafts. A central block consisting of two cylindrical bushes cast or welded at right angles, is placed between the two forks and connected to them by two pins.

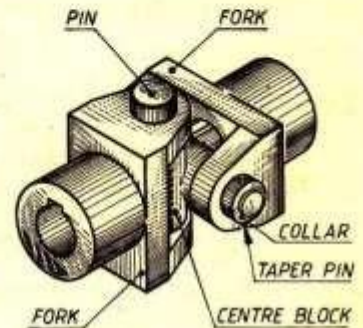

Universal Coupling
Fig.16.31

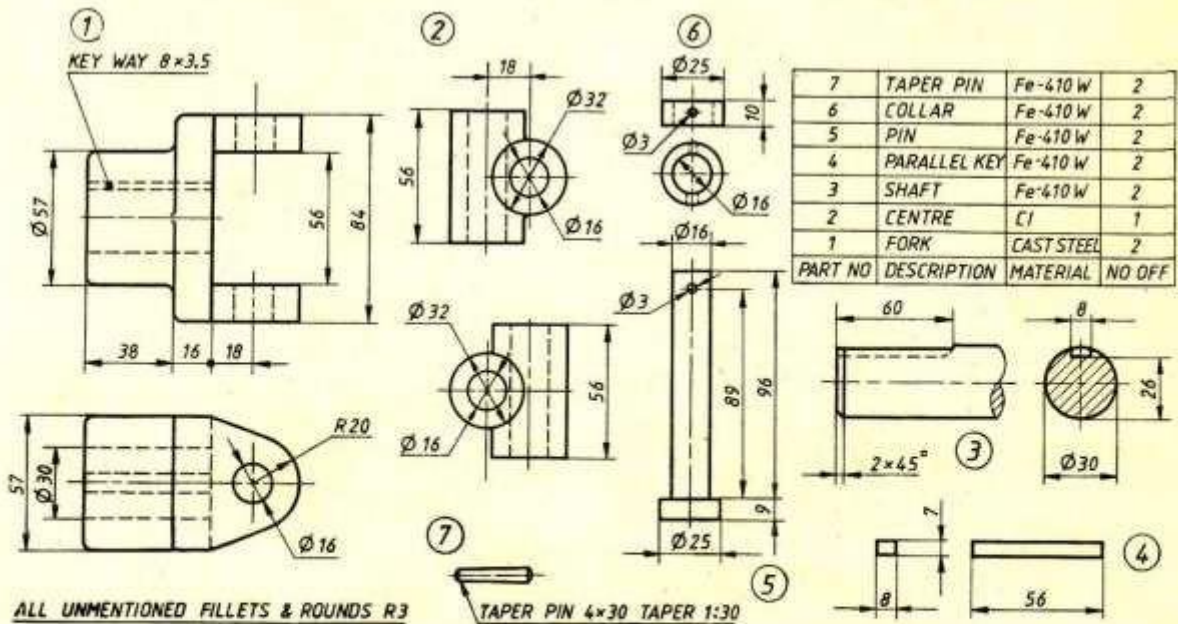

Details of Universal Coupling
Fig.16.32

11. Use revolved cutout command whenever needed.
12. Use the distance between option to maintain accurate distance between one edge and other edge or between one edge and to center the hole.
13. After constructing each part save it as a separate part file with extrusion* par.
14. Enter into assembly environment.
15. Assemble the various parts construct parts construct using the various assembly constraints available (planer, design, mate, axial align, connect etc).
16. After finishing assembly, check whether the various parts have been connected properly or not by rotating the view.
17. Save the assembly.

RESULT

Thus the 3D assembly of the universal coupling has been created on the software PRO- E / Creo with accurate dimension and withal respects.

VIVA-VOCE QUESTIONS

1. What is the use of RIB command?

Ribs are defined as the thin walled structures that are used to increase the strength of the entire structure of the component, so that it does not fail under an increased load.

2. What is the extension SOLIDWORKS file?
sldprt

3. What are the difference between CAD and CAM?

Computer aided drafting (CAD) is the process of creating a design, known as drafting, using computer technology. Computer aided manufacturing (CAM) is the use of computers and computer software to guide machines to manufacture something, usually a part that is mass-produced.

4. How to use Revolve command in SOLIDWORKS?

Using this tool, the sketch is revolved about the revolution axis.

5. What are the important modeling operation?

Extrude, revolve, sweep.

6. Explain about G codes?

G-code is the common name for the most widely used numerical control (NC) programming language, which has many implementations. Used mainly in automation, it is part of computer-aided engineering. G-code is sometimes called G programming language

7. Mention few important G codes?

G00 - Positioning at rapid speed; Mill and Lathe

G01 - Linear interpolation (machining a straight line); Mill and Lathe

G02 - Circular interpolation clockwise (machining arcs); Mill and Lathe

G03 - Circular interpolation, counter clockwise; Mill and Lathe

G20 - Inch units; Mill and Lathe

G21 - Metric units; Mill and Lathe

5. FLANGE COUPLING

AIM

To create the flange coupling assembly as a 3D solid model.

HARDWARE REQUIRED

1. CPU with Pentium IV processor.
2. A color monitor with highest 32 bit color display and with screen resolution 1024 by 768 pixels.
3. A scroll mouse.

SOFTWARE REQUIRED

1. Windows 7 operating system
 2. PRO-E / Creo PROCEDURE
1. Identify various parts to be created.
 2. First enter into part environment and create the main part and create the main part of the assembly.
 3. First identify whether the main part or the first to be created by protrusion or by revolution.
 4. Select the sketch tool and then select the coincidental plane option and select any one of the standard 3 planes (i.e. front, right & top).
 5. Create the cross-section profile as a closed one using the 2D commands available after completing the sketch, click open or return button and then click finish button.
 6. For creating other parts, select sketch both parallel plane option or plane by 3 points option and then select the required plane.
 7. Construct the full cross section for portion and construct the half of the cross section and an axis line for revolution.
 8. Do the protrusions by using protrusion command and the revolution by revolved protrusion command.
 9. For constructing holes and cutout, used hole command and cutout command.

10. Use revolved cutout command whenever needed.
11. Use the distance between option to maintain accurate distance between one edge and other edge or between one edge and to center the hole.
12. After constructing each part save it as a separate part file with extrusion* par.
13. Enter into assembly environment.
14. Assemble the various parts construct parts construct using the various assembly constrains available (planer, design, mate, axial align, connect etc).
15. After finishing assembly, check whether the various parts have been connected properly or not by rotating the view.
16. Save the assembly.

RESULT

Thus the 3D assembly of the flange coupling has been created on the software PRO-E / Creo with accurate dimension and withal respects.

VIVA-VOCE QUESTIONS

1. What is flange coupling?

This is a standard form of coupling. It consists of two cast iron flanges keyed to the end of shafts. The flanges are tightened together by means of a number of bolts

2. What is use of protected type flange coupling?

In this coupling, each flange is provided with a projection. This projection covers the bolt heads and nuts so that they do not catch the fingers or the clothes of workmen.

3. List out some of the modeling software currently available? Solid works, CATIA, Pro-E, IDEAS

4. What is universal coupling?

A universal joint, universal coupling, U-joint, Cardan joint, Hardy-Spicer joint, or Hooke's joint is a joint or coupling in a rigid rod that allows the rod to 'bend' in any direction, and is commonly used in shafts that transmit rotary motion.

5. What are the parts of universal coupling?

It consists of a pair of hinges located close together, oriented at 90° to each other, connected by a cross shaft.

6. What is coupling?

A coupling is a device used to connect two shafts together at their ends for the purpose of transmitting power. Couplings do not normally allow disconnection of shafts during operation, however there are torque limiting couplings which can slip or disconnect when some torque limit is exceeded.

7. What are the types of couplings?

1. Rigid Couplings
2. Flexible or Compensating Couplings

8. What is knuckle joint?

A knuckle joint is used to connect the two rods which are under the tensile load, when there is requirement of small amount of flexibility or angular moment is necessary. There is always axial or linear line of action of load

9. What are the applications of knuckle joint?

Knuckle joint has it applications in the rods for roof, chain link, steam engine valve rod, eccentric rods etc.

10. What is a screw jack?

Screw jack is a mechanical device that can increase the magnitude of an effort force.

6. Force and Stress analysis using link elements in Trusses

Aim:

To conduct the stress analysis of a truss by using ANSYS software

System configuration:

Ram : 8 GB

Processor : Core 2 Quad / Core 2 Duo

Operating system : Windows 7

Software : ANSYS (Version12.0/12.1)

Procedure:

Step 1: Ansys Utility Menu

File – clear and start new – do not read file – ok – yes.

Step 2: Ansys Main Menu – Preferences select – STRUCTURAL - ok

Step 3: Preprocessor

Element type – Add/Edit/Delete – Add – Link – 2D spar 1 – ok – close.

Real constants – Add – ok – real constant set no – 1 – c/s area – 0.1 – ok – close.

Material Properties – material models – Structural – Linear – Elastic – Isotropic – EX – 210e9
ok – close.

Step 4: Preprocessor

Modeling – Create – Nodes – In Active CS – Apply (first node is created) – x,y,z location in CS

– 4 (x value w.r.t first node) – apply (second node is created) – x,y,z location in CS – 4, 3 (x, y value w.r.t first node) – apply (third node is created) – 0, 3 (x, y value w.r.t first node) – ok (fourth node is created).

Create – Elements – Elem Attributes – Material number – 1 – Real constant set number – 1 – ok Auto numbered – Thru Nodes – pick 1 & 2 – apply – pick 2 & 3 – apply – pick 3 & 1 – apply – pick 3 & 4 – ok (elements are created through nodes).

Step 5: Preprocessor

Loads – Define loads – apply – Structural – Displacement – on Nodes – pick node 1 & 4 – apply – DOFs to be constrained – All DOF – ok – on Nodes – pick node 2 – apply – DOFs to be constrained – UY – ok. Loads – Define loads – apply – Structural – Force/Moment – on Nodes- pick node 2 – apply – direction of For/Mom – FX
– Force/Moment value – 2000 (+ve value) – ok – Structural – Force/Moment – on Nodes- pick node 3 – apply – direction of For/Mom – FY – Force/Moment value – -2500 (-ve value) – ok.

Step 6: Solution

Solve – current LS – ok (Solution is done is displayed) – close.

Step 7: General Post Processor

Element table – Define table – Add – „Results data item“ – By Sequence num – LS – LS1 – ok.

Step 8: General Post Processor

Plot Results – Deformed Shape – def+undeformed – ok.

Plot results – contour plot – Line Element Results – Elem table item at node I – LS1 – Elem table item at node J – LS1 – ok (Line Stress diagram will be displayed).

Plot results – contour plot – Nodal solution – DOF solution – displacement vector sum – ok.

List Results – reaction solution – items to be listed – All items – ok (reaction forces will be displayed with the node numbers).

List Results – Nodal loads – items to be listed – All items – ok (Nodal loads will be displayed with the node numbers).

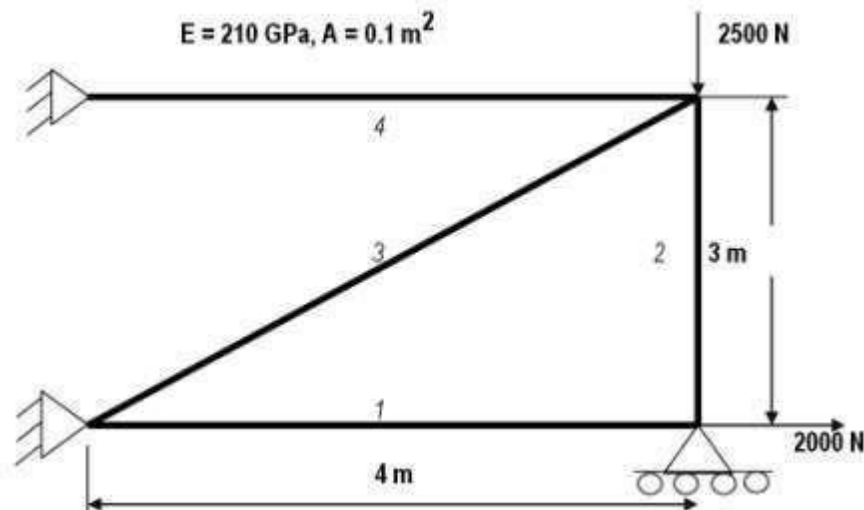

Step 9: PlotCtrls – Animate – Deformed shape – def+undeformed-ok

Result:

Thus the stress analysis of a truss is done by using ANSYS software

7. Stress and deflection analysis in beams with different support conditions

Aim:

To conduct the stress analysis in a simply supported beam using ANSYS software

System configuration:

Ram : 8 GB

Processor : Core 2 Quad / Core 2 Duo

Operating system : Windows 7

Software : ANSYS (Version12.0/12.1)

Procedure:

The three main steps to be involved are

1. Preprocessing

2. Solution

3. Post processing

Start - All Programs – ANSYS 12.0/12.1 - Mechanical APDL Product Launcher – Set the Working Directory as E Drive, User - Job Name as Roll No., Ex. No. – Click Run.

Preprocessing:

1. Preference - Structural – h method – ok

2. Preprocessor - Element type - Add/Edit/Delete - Add - beam 2D elastic 3 –Options – ok– close – real constant- Add/Edit/Delete- Add- area = 100, Izz = 833.33 & height =10- ok

3. Preprocessor – Material Properties – Material Model – Structural – Linear – Elastic – Isotropic – EX 2e5, PRXY0.3 – ok

4. Preprocessor – Modeling – create – nodes – inactive CS Node 1 X=0 Y=0
Node 2 X= 25 Y=0

Node 3 X= 50 Y=0

Node 4 X= 75 Y=0

Node 5 X= 100 Y=0

5. List - nodes - coordinate only –ok

6. Preprocessor- modeling- create- elements- Auto numbered through nodes- select

Node 1 & 2

Node 2 & 3

Node 3 & 4

Node 4 & 5

Node 5 & 6 - ok

7. Solution - define loads- apply- structural - displacement - on nodes - select node 1 & node 5 - apply - UY - displacement = 0 -ok

8. Solution - Force/moment - on nodes - node 3 - apply - FY = -100 -ok

9. Solution - solve - current LS -ok

Post Processing:

10. General post processor - plot result - deform shape - Deformed + Undeformed-ok

11. General post processor - element table - define table - add - user table for item Smax I > by sequence num> NMISC 1 > apply

Smax J > by sequence num> NMISC 3 > apply Smin I > by sequence num> NMISC 2 > apply Smin J > by sequence num> NMISC 4 >ok

12. Plot result - line element result -Smax I-Smax J - first result -Evaluate table data – Smax I, Smax J, Smin I, Smin J -ok

13. General postprocessor - list result - nodal solution - DOF solution - UY-displacement result

14. General postprocessor - contour plot - line element res. -ok

Result:

Thus the stress analysis of a simply supported beam is done by using the ANSYS Software.

8. STRESS ANALYSIS OF FLAT PLATES

Aim:

To conduct the stress analysis in a plate with a circular hole using ANSYS software

System configuration:

Ram : 8 GB

Processor: Core 2 Quad / Core 2 Duo

Operating system: Windows 7

Software : ANSYS (Version12.0/12.1)

Procedure:

The three main steps to be involved are

1. Pre Processing
2. Solution
3. Post Processing

Start - All Programs – ANSYS 12.0/12.1 - Mechanical APDL Product Launcher – Set the Working Directory as E Drive, User - Job Name as Roll No., Ex. No. – Click Run.

Preprocessing:

1. Preference - Structural- h-Method - ok
2. Preprocessor - Element type - Add/Edit/Delete – Add – Solid, 8 node 82 – ok – Option – choose Plane stress w/thk - close
3. Real constants - Add/Edit/Delete – Add – ok – THK 0.5 – ok - close
4. Material props - Material Models – Structural – Linear – Elastic – Isotropic - EX 2e5, PRXY 0.3 - ok
5. Modeling – Create – Areas – Rectangle - by 2 corner - X=0, Y=0, Width=100, Height=50 - ok - Circle - Solid circle - X=50, Y=25, Radius=10 - ok-operate –Booleans – Subtract – Areas - Select the larger area (rectangle) – ok – Select Circle – Next –ok
6. Meshing - Mesh Tool – Area – Set - Select the object – ok - Element edge length2/3/4/5– ok - Mesh Tool - Select TRI or QUAD - Free/Mapped – Mesh - Select theobject –ok

Solution:

7 Solution – Define Loads – Apply – Structural – Displacement - On lines - Select the boundary where is going to be arrested – ok - All DOF - ok. Pressure - On lines - Select the load applying area – ok - Load PRES valve = 1N/mm – ok

8. Solve – Current LS – ok– Solution is done – close

Post processing:

9. General post proc - Plot Result - Contour plot - Nodal Solution – Stress –Von mises stress – ok
10. Plot control – Animates - Mode Shape – Stress - Von mises – ok
11. Plot control – Animate - Save Animation - Select the proper location to save the file (E drive-user) – ok
12. File – Report Generator – Choose Append – ok – Image Capture – ok - close

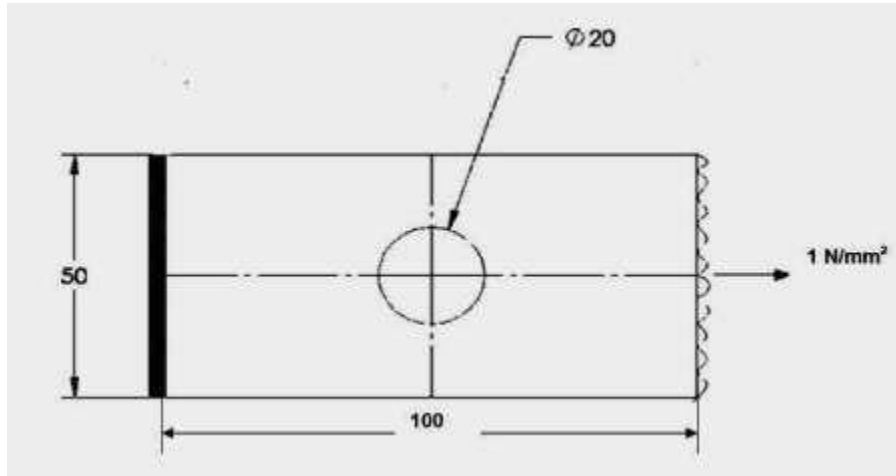

Young's Modulus : 5 N/mm^2
 2×10 Poisson's ratio :
0.3

Result:

Thus the stress analysis of rectangular plate with a circular hole is done by using the ANSYS Software.

9. Stress analysis of axis-symmetric components

Aim:

To obtain the stress distribution of an axisymmetric component

The model will be that of a closed tube made from steel. Point loads will be applied at the centre of the top and bottom plate.

System configuration:

Ram : 8 GB
Processor : Core 2 Quad / Core 2 Duo
Operating system: Windows 7
Software : ANSYS (Version12.0/12.1)

Procedure:

The three main steps to be involved are

1. Preprocessing
2. Solution
3. Post processing

Preprocessing:

1. Utility Menu - Change Job Name - Enter Job Name. Utility Menu - File - Change Title - Enter New Title
2. Preference - Structural -h method - ok
3. Preprocessor - Element type - Add/Edit/ delete - solid 8node 183 - options-axisymmetric
4. Preprocessor - Material Prop - Material Model - Structural - Linear - Elastic -Isotropic - EX = 2e5, PRXY = 0.3
5. Preprocessor -Modeling -create- Areas-Rectangle - By dimensions

Rectangle	X1	X2	Y1	Y2
1	0	20	0	5
2	15	20	0	100
3	0	20	95	100

6. Preprocessor - Modeling - operate - Booleans - Add - Areas - pick all -ok
7. Preprocessor - meshing - mesh tool - size control - Areas - Element edge length = 2 mm -ok- mesh - Areas - free- pick all.

Solution:

8. Solution - Analysis Type-New Analysis-Static
9. Solution - Define loads - Apply .Structural - displacement - symmetry BC - on lines. (Pick the two edger on the left at X = 0)

10. Utility menu - select - Entities - select all
11. Utility menu - select - Entities - by location - Y = 50 -ok.
12. Solution - Define loads - Apply - Structural - Force/Moment - on key points - FY =100 - Pick the top left corner of the area -ok
13. Solution - Define Loads - apply - Structural - Force/moment - on key points - FY =-100- Pick the bottom left corner of the area -ok
14. Solution - Solve - Current LS
15. Utility Menu - select - Entities
16. Select nodes - by location - Y coordinates and type 45, 55 in the min., max. box, as shown below and click ok

Post processing:

17. General postprocessor - List results - Nodal solution - stress - components SCOMP
18. Utility menu - plot controls - style - Symmetry expansion - 2D Axisymmetric - $\frac{3}{4}$ expansion

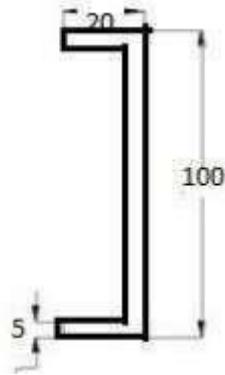

Young's Modulus : 200 GPa Poisson's ratio : 0.3

Result:

Thus the stress analysis of an axi-symmetric component done by using the ANSYS software.

10. Thermal stress and heat transfer analysis of plates

Aim:

To conduct the thermal stress analysis of a 2D component by using ANSYS software

System configuration:

Ram : 8 GB
Processor : Core 2 Quad / Core 2 Duo
Operating system: Windows 7
Software : ANSYS (Version12.0/12.1)

Procedure:

The three main steps to be involved are

1. Preprocessing
2. Solution
3. Post processing

Start - All Programs – ANSYS 12.0/12.1 - Mechanical APDL Product Launcher – Set the Working Directory as E Drive, User - Job Name as Roll No., Ex. No. – Click Run.

Preprocessing:

1. Preference – Thermal - h-Method - ok
2. Preprocessor - Element type - Add/Edit/Delete – Add – Solid, Quad 4 node 42 – ok – Options – plane strsw/thk – ok – Close
3. Real constants - Add/Edit/Delete – Add – ok – THK 100 – ok – Close
4. Material props - Material Models –Structural – Linear – Elastic - Isotropic – EX 2e5,PRXY 0.3 – ok –Thermal expansion – Secant coefficient – Isotropic – ALPX 12e-6 – ok
5. Modeling – Create – Areas - Rectangle – by 2 corners – Enter the coordinate values, height, width- ok
6. Meshing – Mesh tool – Areas, set – select the object – ok – Element edge length 10 -ok – Mesh tool- Tri, free - mesh – Select the object

Solution:

7. Solution – Define Loads – Apply – Structural – Displacement - On lines – Select the boundary on the object –ok – Temperature – Uniform Temp – Enter the temp. Value 50 –ok.
8. Solve – Current LS – ok – Solution is done – close

Post processing:

9. General post proc – Plot results – Contour plot – Nodal solution – Stress – 1st principal stress – ok – Nodal solution – DOF Solution – Displacement vector sum - ok
10. File – Report Generator – Choose Append – ok – Image Capture – ok - close

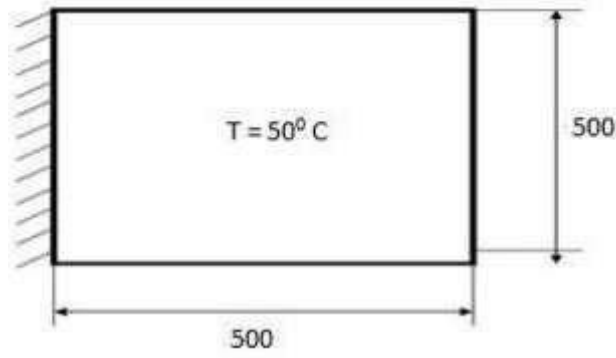

Young's Modulus = 200 GPa

Poisson's ratio = 0.3

Result:

Thus the thermal stress analysis of a 2D component is done by using the ANSYS Software.

11.

Thermal stress analysis of cylindrical shells.

Aim:

To conduct the thermal stress analysis of of cylindrical shells

System configuration:

Ram : 8 GB
Processor : Core 2 Quad / Core 2 Duo
Operating system : Windows 7
Software : ANSYS (Version12.0/12.1)

Procedure:

The three main steps to be involved are

1. Preprocessing
2. Solution
3. Post processing

Preprocessing:

1. Preference – structural - h-Method - ok
2. Preprocessor - Element type - Add/Edit/Delete – Add – Solid, Quad 4 node 55 – ok – Close
3. Real constants - Add/Edit/Delete – Add – ok
4. Material props - Material Models –Thermal – Conductivity – Isotropic – KXX 16 – ok
5. Modeling – Create – Key points - In active CS – enter the key point number and X, Y, Z location for 8 key points to form the shape as mentioned in the drawing. Lines – lines - Straight line - Connect all the key points to form as lines. Areas – Arbitrary - by lines - Select all lines - ok.
6. Meshing – Mesh tool – Areas, set – select the object – ok – Element edge length 0.05 - ok – Mesh tool- Tri,free mesh – Select the object –ok

Solution:

7. Solution – Define Loads – Apply – Thermal – Temperature - On lines – Select the lines–ok – Temp. Value 300 – ok – Convection – On lines – select the appropriate line – ok – Enter the values of film coefficient 50, bulk temperature 40 –ok

8. Solve – Current LS – ok – solution is done – Close

Post Processing:

9. General post proc – List results – Nodal Solution – DOF Solution – Nodal temperature – ok

10. Plot results – Contour plot – Nodal solution – DOF solution – Nodal Temperature – ok

11. File – Report Generator – Choose Append – ok – Image Capture – ok - Close

Thermal Conductivity of the material = $16 \text{ W/m} \cdot \text{K}$

Result:

Thus the convective heat transfer analysis of a cylindrical shell is done by using the ANSYS Software.

12. Vibration analysis of spring-mass systems

Aim:

To conduct the Vibration analysis of spring-mass systems

System configuration:

Ram : 8 GB

Processor : Core 2 Quad / Core 2 Duo

Operating system : Windows 7

Software : MATLAB

Procedure:

A mass on a spring with a velocity-dependent damping force and a time-dependent force acting upon it will behave according to the following equation:

$$m\ddot{x} + c\dot{x} + kx = f(t)$$

The model will be formed around this equation. In this equation, 'm' is the equivalent mass of the system; 'c' is the damping constant; and 'k' is the constant for the stiffness of the spring. First we want to rearrange the above equation so that it is in terms of acceleration; then we will integrate to get the expressions for velocity and position.

Rearranging the equation to accomplish this, we get:

$$\ddot{x} = \frac{1}{m}(f(t) - c\dot{x} - kx)$$

To build the model, we start with a 'step' block and a 'gain' block. The gain block represents the mass, which we will be equal to 5. We also know that we will need to integrate twice, that we will need to add these equations together, and that there are two more constants to consider. The damping constant 'c' will act on the velocity, that is, after the first integration, and the constant 'k' will act on the position, or after the second integration. Let $c = 0.35$ and $k = 0.5$. Laying all these block out to get an idea of how to put them together, we get:

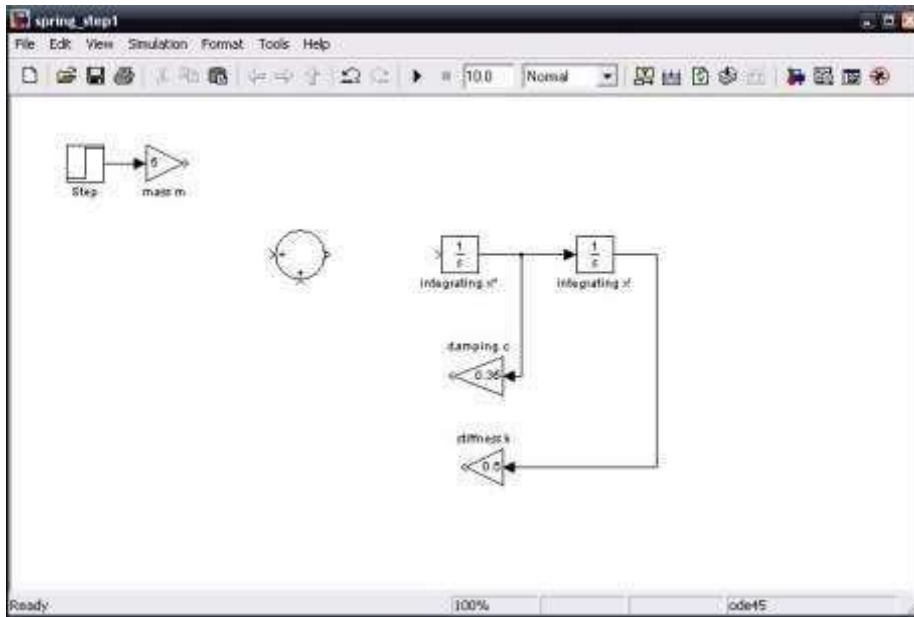

By looking at the equation in terms of acceleration, it is clear that the damping term and spring term are summed negatively, while the mass term is still positive. To add places and change signs of terms being summed, double - click on the sum function block and edit the list of signs:

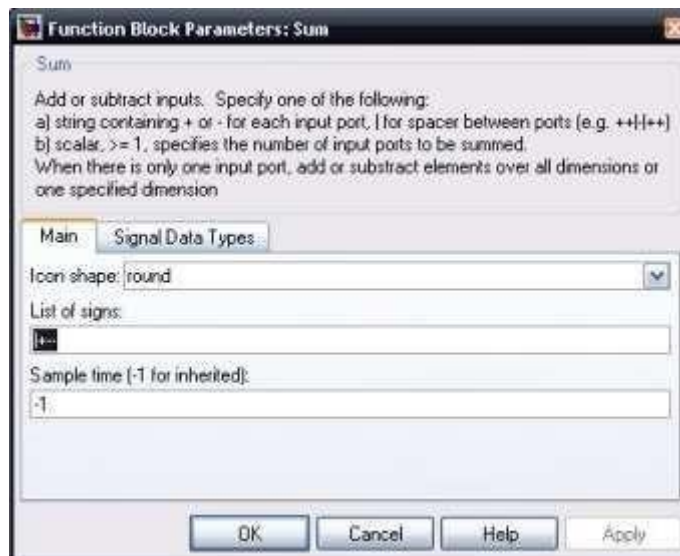

Once we have added places and corrected the signs for the sum block, we need only connect the lines to their appropriate places. To be able to see what is happening with this spring system, we add a 'scope' block and add it as follows:

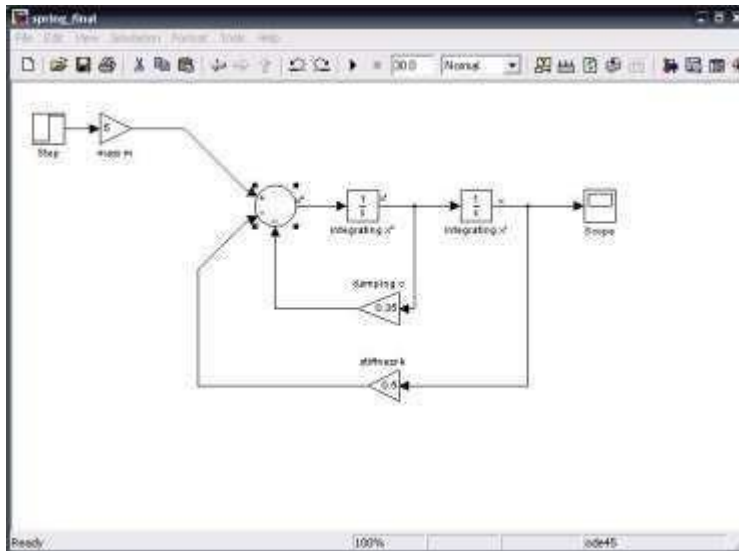

The values of 'm', 'c' and 'k' can be altered to test cases of under-damping, critical-damping and over-damping. To accurately use the scope, right-click the graph and select "Autoscale". The mdl-file can now be saved.

Result:

Then the simulation is verified for spring-mass system using MATLAB software, when the model is run for 30 iterations.

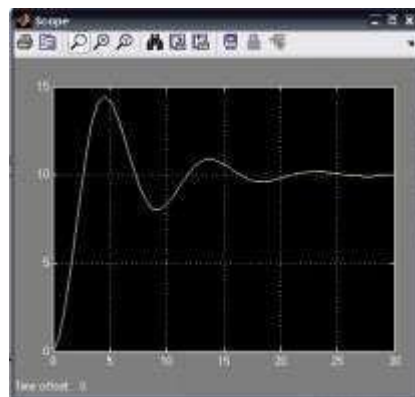

SIMULATION AND ANALYSIS LAB VIVA QUESTIONS

1) What are the different approximate solution methods?

1. Functional approximation
2. Finite Difference method
3. Finite Element method

2) What do you mean by continuum.

Structure which is considered for analysis is called continuum.

3) Define term node

The element which is connected with another element at junction is called node.

4) Define term element

Discretised structure is called an element .

5) What is convergence?

Process of achieving value to actual solution.

6) What are the types convergence?

p-convergence

h-convergence

7) What is p- convergence? Convergence by

increasing the elements

8) What is h convergence?

Convergence by increasing nodes

9) What is higher order elements?

The element which contain more no. of nodes are called higher order element .

10) Give example for higher order elements

Higher order elements are CST, Quadrilateral element.

11) What do you mean by compatible elements?

Elements, which are compatible with adjacent element, like no discontinuity, overlap or sudden slope.

12) What is geometric invariance?

The property in which the shape of the element will not change with change in local coordinates is called geometric invariance.

13) Why do we use Pascal's triangle in FEA?

If the displacement equation doesn't contain all the required terms then balancing is done by the Pascal's triangle.

14) What are the steps involved in FEA?

Steps involved in FEA:

1. Modelling
2. Discretization of structure

3. Derivation of elemental stiffness matrix.
4. Assembly of elemental equation
5. Applying boundary conditions
6. Computation of stress and strain
7. Interpretation of results

15) What is stiffness matrix?

The matrix which contains parameters like E, A, displacement and applied force is stiffness matrix

16) How to obtain stiffness matrix?

Stiffness matrix can be obtained by applying condition of minimum potential energy to potential energy equation.

17) What is displacement function?

Displacement function is the assumed polynomial equation, which satisfies boundary conditions.

18) How to identify order of elements?

Order of elements depends on the no. of nodes.

19) Mention different types of elements.

Different types of elements are bar elements, beam element, truss element, shell element, axis symmetric.

20) Mention some application of FEA.

Mechanical, Aerospace, Civil, structure analysis, biomedical, geo-mechanics, electromagnetic.

21) What is connectivity?

Relation between the connected elements is connectivity.

22) What are the methods to improve problem solution?

Problem solution can be improved by increasing no. of elements or no. of nodes.

23) Define symmetry in matrix.

It is the square matrix in which the element of the row are same as that of element of column.

24) What is plane stress? Stress acting on 2-D element.

25) What is plane strain?

Strain occurring in 2-D element.

26) Compare FEA with solid mechanics.

Complicated irregular structures are difficult in solid mechanics but FEA it's easier with greater accuracy.

27) What are the packages available for FEA?

packages available for FEA: ANSYS, I-DEAS, NASTRAN, ABAQUS, COSMOS, ALGOR, PATRAN.

28) Define potential energy.

Energy possessed by the body due to its position

29) Define minimum potential energy.

for conservative system of all kinematically admissible displacement fields those corresponding to equilibrium extremize the total potential energy if extreme condition is a minimum the equilibrium state is stable

30) Write potential energy equation for cantilever beam

$$= EI/2 \int_0^L (d^2y/dx^2)^2 dx - P\delta$$

31) Mention 2 different methods to approach the model of physical system .

Discrete system , continuum

33) What is local coordinate?

local coordinate contains 1-D.O.F. at each node.

34) What is global coordinate?

Global coordinate contains 2-D.O.F. at each node.

35) General assumption made in stress

Assumptions:

1. Truss elements are connected by frictionless pins. 2. Load is applied on the load.

3. Only two forces compressive and tensile are considered.

36) What is shape function?

It is mathematical polynomial, which gives displacement within the element.

37) What are two general natural coordinates? Two

general coordinates are ξ and η .

38) Mention the range of natural coordinate. Range of

natural coordinates is -1 to 1 and -1 to 1 .

39) What is the number of shape function in CST?

Number of shape functions in CST are three.

40) What is the number of shape function in quadrilateral?

Number of shape functions in quadrilateral are 4.

41) Why are we using natural integration?

We are using natural integration to simplify the problem.

42) Explain one point formula.

1-point shape function contains one term $f(x)dx = w_1 f(x)$

43) Explain two point formula.

2-point shape function contains two terms $f(x)dx = w_1 f(x_1) + w_2 f(x_2)$

44) Why are we using polynomial equations in FEA?

Polynomial equations give continuous solutions & it is simple to solve the problem.

45) What are the two important characteristics of the stiffness matrix?

Characteristics of the stiffness matrix are symmetric and banded

47) Mention two schemes to represent band width.

Horizontal numbering and Vertical numbering

48) What are forces involved in work potential?

Forces involved are Body force, Traction force and Point force

49) What is isoparametric elements?

These are those the S.F. used to define variables of displacement equal to S.F. used to represent geometry.

50) What is orthotropic elements?

Material which has three orthogonal planes of symmetry said to be orthotropic elements. Only nine constants are required to describe constituent equation

51) What is anisotropic elements?

The material which doesn't contain any plane of symmetry

52) What is isotropic elements?

isotropic material is one in which every plane is plane of symmetry only two constants are enough to describe constituent equation

53) What is super parametric elements?

$GSF > DSF$ (geometric shape function, displacement shape function 54)

What is sub parametric elements

$GSF < DSF$

55) Different coordinates involved in chain rule.

Different coordinates involved in chain rule are normal , local and displacement coordinates .

56) What are the 2 different approaches to study elasticity ?

Strength of material , Theory of elasticity

57) Mention any two methods to solve continuum problems.

1. Raleigh Ritz method

2. Galerkin method

58) List the properties of shape functions. SF for

1D bar element $N_1=0, N_2= 0$ at node 1

$N_1=0, N_2= 1$ at node 2 .

Diff. Of S.F. S.F are constant

59) Define truss.

Structural member which is subjected to either tensile or compression

60) What is weighted residual methods?

It's a method in FEA for accurate solution avoiding error (residue = error)

61) Different methods to solve weighed residual problem. Point

allocation, Sub domain , Galerkin, least square.

62) Explain the principle of virtual work.

If the force and displacement are unrelated by cause effect relation then the work is said to be virtual work.

63) Explain the principle of virtual displacement.

Actual displacement is considered without bothering amount of force is called virtual displacement .

64) What are different types of shape functions?

Diff types are Lagrangian and Hermite Shape function

65) Differentiate two types of shape functions.

Lagrangian shape function only for variable

Hermite shape function is for both variable and its derivative

66) Mention some advantages of FEA over solid mechanics.

1. Applied for complicated structure

2. Analysis is simple

3. More accurate solution

67) Define Young's Modulus and Poisson's Ratio.

E - It is the ratio of stress and strain

μ - It is the ratio of lateral strain and longitudinal strain

68) Mention different types of elastic constants.

Young's modulus, shear modulus, bulk modulus

69) Specify the terms required to solve FEA problem.

Meshing , properties of material, boundry condition and initial condition.

70) What are the assumptions made in linear static problems.

all displacement is small, material is isotropic, linear, elastic solid with E and

71) Which is the most accepted form of numerical integration in FEM?

Gaussian Quadrature

72) List the different approaches to derive integral equation

Direct method , variation method, weighed residual method, energy method

73) What are the advantages of symmetrical matrix.

symmetrical matrix simplifies the calculation

74) What are the different types of errors in FEA?

Modeling error , Discretized and Numerical error

75) What are the advantages of isoparametric elements Useful

in modeling structure with curved edges

They are versatile & they are used in 2-D and 3-D elasticity problems

76). Define frontal method for finite element matrices.

In 3- dimensional problems, the size of the stiffness matrix increases rapidly even with the banded method of modeling.

77) What is the another name of the 3-dimensional frames?

Space frames.

78). Define beam elements.

Beam elements are slender members that are used for supporting transverses loading.

79) Explain preprocessor steps.

Determining the Nodal coordinates, connectivity, boundary condition, material information

80) Explain processing steps.

Stiffness generation, modification, solutions to the equation resulting in evolution.

81) Explain post processing steps.

Deformation confirmation, mode shapes, temperature and stress distribution, interpretation

82) What are the difference b/w beams and plane frames?

It is similar to beams expect that axial loads & axial deformations are present. The elements also have different orientation.

83) Mention some common material properties.

Isotropic, orthotropic, ductility, brittleness

84) What are the different types of analysis.

Thermal, structural (load), fluid, electromagnetic analysis

85) Define steady state analysis.

The analysis carried out at constant temperature.

86) What is the advantage of subjecting solids to axisymmetric loading.

Axisymmetric loading reduces the 3-D problem into 2-D problems because of total symmetry about the z-axis.

87) Define CST elements.

The constant strain triangle is that where the displacement inside an element is represented by 3-nodal displacement (3-shape functions).

88) How to generate the data files for larger problems in FEA?

Using MESHGEN program generates data files.

89) Define mesh plotting

It is the convenient way of reviewing the coordinate and connectivity data is by plotting it using computer.

90) Explain lumped mass matrices.

It is the total element mass in each direction is distributed equally to the nodes of the element, and the masses are associated with translational degrees of freedom.

91) Briefly explain steps involved in Lagrangian method

Formulation of potential energy function. Assuming displacement function
Checking displacement function considering boundary condition
Substitute differential function in potential energy equation Potential
energy function is minimized
Unknown parameters are determined and substituted in assumed equation

92) Explain steps involved in Galerkin's method.

Formulate differential equation of the equilibrium

Assume trial function, which satisfies boundary conditions

Substitute displacement function in differential equation then assume the difference due to approx. function be
„R“ (residue)

Use Galerkin formula

Determine unknown terms and then substitute in differential function

93) Define Jacobian matrix.

The matrix which is defined explicitly in terms of the local coordinate is known as Jacobian (J).

94) Mention six components of stress.³

linear stress along x, y, z direction

3 lateral stress along x, y, z direction

95) Mention six components of strain.³

linear strain along x, y, z direction

3 lateral strain along x, y, z direction

96) Define Winkler foundations.

Large beams are supported on soil from a class of applications known as Winkler foundations.

97) Define variational principle

The problem which specifies a scalar quantity potential energy is defined in an integral form.

98) How to solve the prismatic problems.

The coefficients of the ordinary differential equation are independent of one of the coordinates and the solution of the system can frequently be carried out efficiently by standard analytical methods.

99) Define stress & strain.

Stress is the ratio of applied load to its area.

Strain is the ratio of change in length to its original length.

100) Mention the two distinct procedures available for obtaining the approximation in the integral forms.

Method of weighted residuals. Method of
variation functional.

SIMPLE TURNING OPERATION USING G01 BILLET SIZE ϕ 25.4 L=70

AIM

To write the part programming and simulation them to the given lathe job.

TOOLS AND EQUIPMENTS

1. CNC simulation software FANUC
2. CNC trainer software
3. Software Pentium IV

PROCEDURE

1. To write the program for given job.
2. To type G and M CODES.
3. To give the tool size and stock dimensions.
4. Finally to run the machine to the operation.

PROGRAM

```
G21 G98 G28
U0 W0M06
T0101M03
S1500G00 X26
Z1
G01 X25 F50G01
Z-30 F50G01
X26 F50G01 Z1
F50 G01 X24
F50G01 Z-30
F50G01 X26 F50
G01 Z1 F50 G01
X23 F50
G01 Z-30 F50
    G01 X26 F50
G01 Z1 F50 G01
X22 F50 G01 Z-
30 F50G01 X26
F50 G01 Z1 F50
G01 X18 Z0 F50
G03 X22 Z-2 R2 F40
```

M-CODES

M06 – Tool Change
M03 – Spindle Forward Clockwise
M05 – Spindle Stop
M30 – Program End

G-CODES

G21 – Metric
G98 – Feed/Min
G28 U0 W0 – Reference Point Return
G00 X Y – Positioning (Rapid Traverse)
G01 X Y F – Linear Interpolation (Feed)
G03 – Circular Interpolation (CCW) G90
– Cutting Cycle Turning

G28 U0 W0
M05
M30

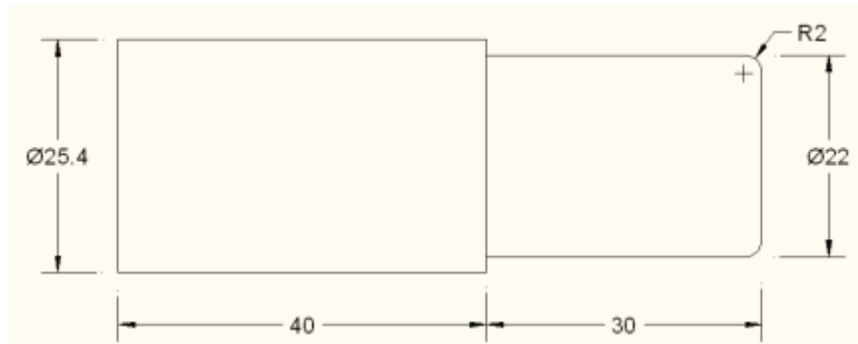

RESULT

Thus the part program was written and simulated for given job.

STEP TURNING USING CYCLE G90 BILLET SIZE $\phi 25.4$ L=70

AIM

To write the part programming and simulation them to the given lathe job.

TOOLS AND EQUIPMENTS

1. CNC simulation software FANUC
2. CNC trainer software
3. Software Pentium IV

PROCEDURE

1. To write the program for given job.
2. To type G and M CODES.
3. To give the tool size and stock dimensions.
4. Finally to run the machine to the operation.

PROGRAM

```
G21 G98 G28
U0 W0M06
T0101M03
S1500G00 X26
Z1
G90 X25 Z-40 F50
X24
X23X22
G90 X21 Z-28 F50
X20
X19X18X17
X16
G90 X15 Z-10 F50
X14
X13X12
G28 U0 W0
M05
M30
```

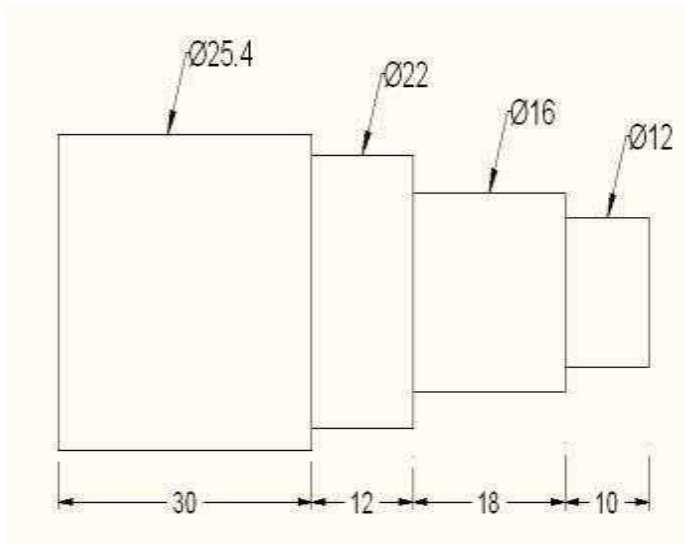

RESULT

Thus the part program was written and simulated for given job.

PROFILE TURNING USING MULTIPLE TURNING CYCLE (G71)

AIM

To write the part programming and simulation them to the given lathe job.

TOOLS AND EQUIPMENTS

1. CNC simulation software FANUC
2. CNC trainer software
3. Software Pentium IV

PROCEDURE

1. To write the program for given job.
2. To type G and M CODES.
3. To give the tool size and stock dimensions.
4. Finally to run the machine to the operation.

PROGRAM

```
G21 G98 G28
U0 W0M06
T0101M03
S1200G00 X26
Z1
G71 U0.5 R1.0
G71 P01 Q02 U0.2 W0.2 F50
N01 G01 X8
G01 Z0
G01 X10 Z-2
G01 X10 Z-12
G02 X15 Z-14.5 R2.5
G01 X15 Z-24.5
G03 X20 Z-27 R2.5
G01 X20 Z-32
N02 G01 X25.4 Z-32
G70 P01 Q02 F40 G28
U0 W0
M05
M30
```

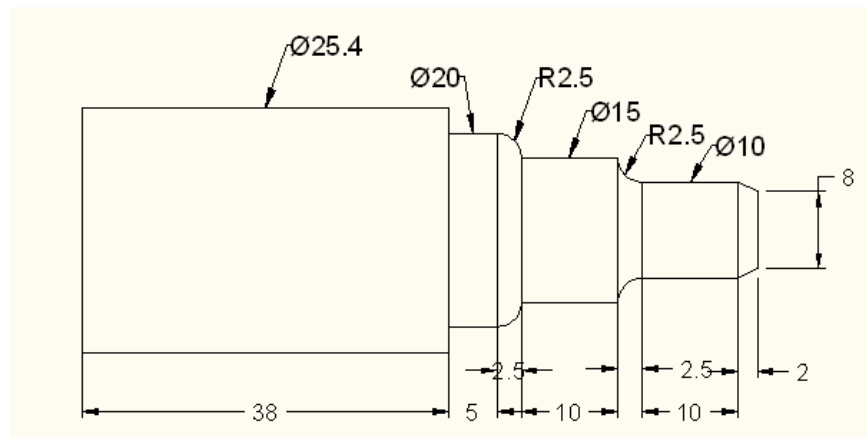

G71 – Multiple Turing cycle (stock remover)G
70 – Finishing cycle

G71 U R
G71 P Q U W F
G70 P Q

G71 – Multiple Turning CycleU
– Depth of Cut
R – Retract Allowance

G71 – Multiple Turing CycleP
– Starting Block (N01)
Q – Ending Block (N02)
U – Finishing Allowance in X-Axis
W – Finishing Allowance in Z-AxisF
– Feed Rate

G70 – Finishing CycleP
– Starting Block
Q – Ending Block

RESULT

Thus the part program was written and simulated for given job.

TAPER TURNING (R- & R+) USING BOX TURNING CYCLE (G90) BILLET SIZE $\phi 25.4$ L=70

AIM

To write the part programming and simulation them to the given lathe job
TOOLS AND EQUIPMENTS

1. CNC simulation software FANUC
2. CNC trainer software
3. Software Pentium IV

PROCEDURE

1. To write the program for given job.
2. To type G and M CODES.
3. To give the tool size and stock dimensions.
4. Finally to run the machine to the operation.

PROGRAM

```
G21 G98 G28
U0 W0M06
T0101M03
S1500G00 X26
Z1
G90 X25 Z-35 F50
G90 X24 Z-5 F50
X23
X22
X21
X20 G00 X26
Z-5
G90 X25 Z-15 R0 F50 X25
Z-15 R-0.5 F50X25 Z-15
R-1.0 F50X25 Z-15 R-1.5
F50X25 Z-15 R-2.0 F50X25
Z-15 R-2.5 F50
G00 X26 Z-20
G90 X25 Z-30 R0 F50 X24
Z-30 R0.5 F50X23 Z-30
R1.0 F50X22 Z-30 R1.5
F50
      X21 Z-30 R2.0 F50
X20 Z-30 R2.5 F50G00
X26 Z-30
G90 X24 Z-35 F50
X23
X22
X21
```

R⁺

REVERSE TAPER $R^+ = (25 - 20)/2 = +2.5$
FORWARD TAPER $R^- = (20 - 25)/2 = -2.5$

Taper Turning

G90 X Z R F
R – Taper Value
F – Feed Rate

X20
G28 U0 W0
M05
M30

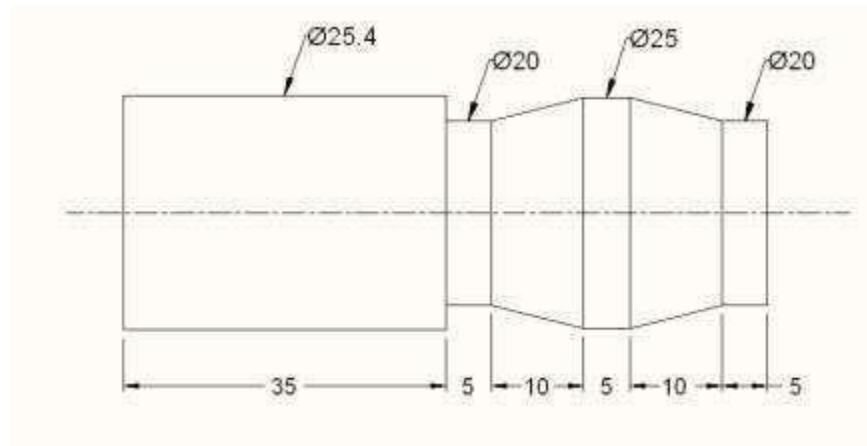

RESULT

Thus the part program was written and simulated for given job.

THREAD CUTTING USING BOX CYCLE (G92) BILLET SIZE $\phi 25.4$ L=70

AIM

To write the part programming and simulation them to the given lathe job.

TOOLS AND EQUIPMENTS

1. CNC simulation software FANUC
2. CNC trainer software
3. Software Pentium IV

PROCEDURE

1. To write the program for given job.
2. To type G and M CODES.
3. To give the tool size and stock dimensions.
4. Finally to run the machine to the operation.

PROGRAM

```
G21 G98 G28
U0 W0M06
T0101M03
S1500G00 X26
Z1
G90 X25 Z-40 F50
X24
X23
X22
G28 U0 W0M06
T0202M03 S300
G00 X26 Z1
G92 X22 Z-20 F2
X21.95 X21.90
X21.85 X21.80
X21.75 X21.70
X21.65 X21.60
X21.55 X21.50
X21.45 X21.40
X21.35 X21.30
```

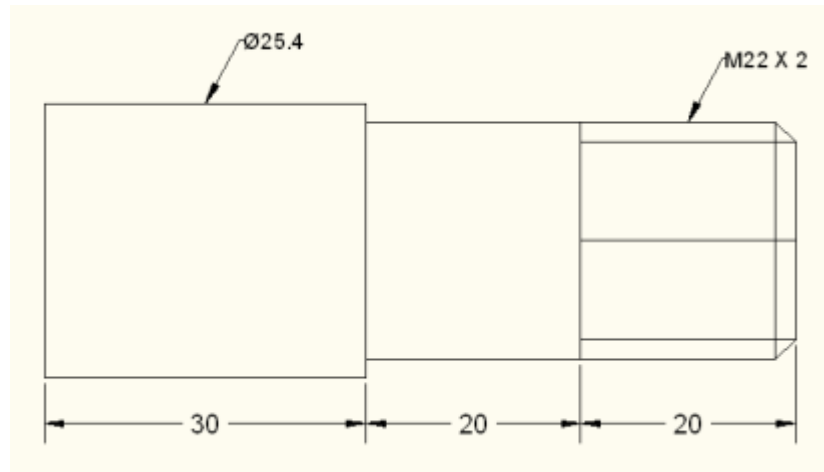

G92 Thread Cutting Cycle
Syntax G92 X_ Z_ F_

Feed = Pitch = 2 mm

Calculation of Mirror Diameter (d)

$d = D - 2h$

$= D - 2 \times (0.615 \times P)$

$= 22 - 2 \times (0.615 \times 2)$

```
X21.25X21.20
X21.15X21.10
X21.05X21
X20.95X20.90
X20.85X20.80
X20.75X20.70
X20.65X20.60
X20.55X20.50
X20.45X20.40
X20.35X20.30
X20.25X20.20
X20.15X20.10
X20.05X20
X19.95X19.90
X19.85X19.80
X19.75X19.70
X19.65X19.60
X19.54
G28 U0 W0
M05
M30
```

RESULT

Thus the part program was written and simulated for given job.

LINEAR AND CIRCULAR INTERPOLATION BILLET SIZE

AIM

To write the part programming and simulation them to the given milling job.

TOOLS AND EQUIPMENTS

1. CNC simulation software
2. CNC milling software
3. Software Pentium IV

PROCEDURE

1. To write the program for given job.
2. To type G and M CODES.
3. To give the tool size and stock dimensions.
4. Finally to run the machine to the operation.

PROGRAM

```
G21 G94
G91 G28
Z0
G28 X0 Y0
M06 T1 M03
S1500G90
G00 X30 Y20
G00 Z5
G01 Z-0.5 F30 G01
X70 Y20 F50
G03 X80 Y30 R10 F50
G01 X80 Y70 F50G01
X70 Y80 F50G01 X30
Y80 F50G02 X20 Y70
R10G01 X20 Y30 F50
G01 X30 Y20 F50G01
Z5 F50
G91 G28
Z0
G28 X0 Y0
M05
M30
```

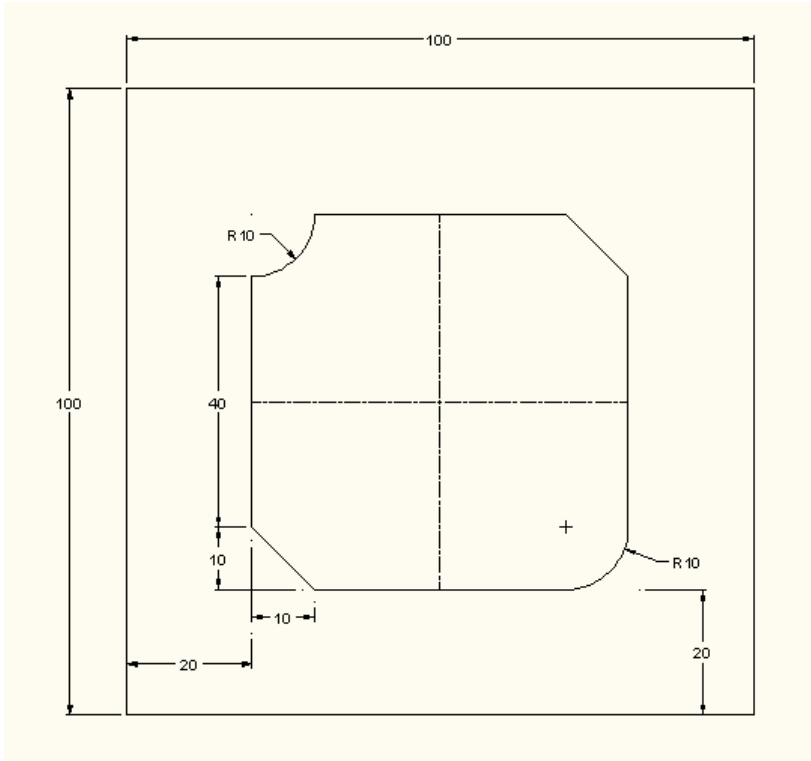

RESULT

Thus the part program was written and simulated for given job.

CIRCULAR INTERPOLATION CCW

AIM

To write the part programming and simulation them to the given milling job.

TOOLS AND EQUIPMENTS

1. CNC simulation software
2. CNC milling software
3. Software Pentium IV

PROCEDURE

1. To write the program for given job.
2. To type G and M CODES.
3. To give the tool size and stock dimensions.
4. Finally to run the machine to the operation.

PROGRAM

```
G21 G94
G91 G28
Z0
G28 X0 Y0
M06 T1 M03
S1500G90
G00 X30 Y20
G00 Z5
G01 Z-0.5 F30 G01
X70 Y20 F50
G03 X80 Y30 R10 F50
G01 X80 Y70 F50G03
X70 Y80 R10 F50G01
X30 Y80 F50G03 X20
Y70 R10 F50G01 X20
Y30 F50
G03 X30 Y20 R10 F50
G91
G28 Z0
```

G28 X0 Y0
M05
M30

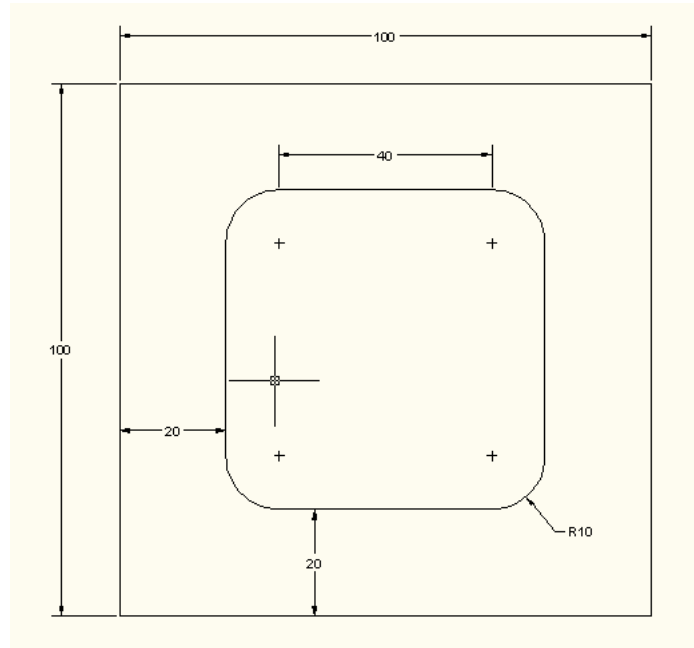

RESULT

Thus the part program was written and simulated for given job.

CIRCULAR INTERPOLATION-CW

AIM

To write the part programming and simulation them to the given milling job.

TOOLS AND EQUIPMENTS

1. CNC simulation software
2. CNC milling software
3. Software Pentium IV

PROCEDURE

1. To write the program for given job.
2. To type G and M CODES.
3. To give the tool size and stock dimensions.
4. Finally to run the machine to the operation.

PROGRAM

```
G21 G94
G91 G28
Z0
G28 X0 Y0
M06 T1 M03
S1500G90
G00 X30 Y20
G00 Z5
G01 Z-0.5 F30 G01
X70 Y20 F50
G02 X80 Y30 R10 F50
G01 X80 Y70 F50G02
X70 Y80 R10 F50G01
X30 Y80 F50G02 X20
Y70 R10 F50G01 X20
Y30 F50
G02 X30 Y20 R10 F50
```

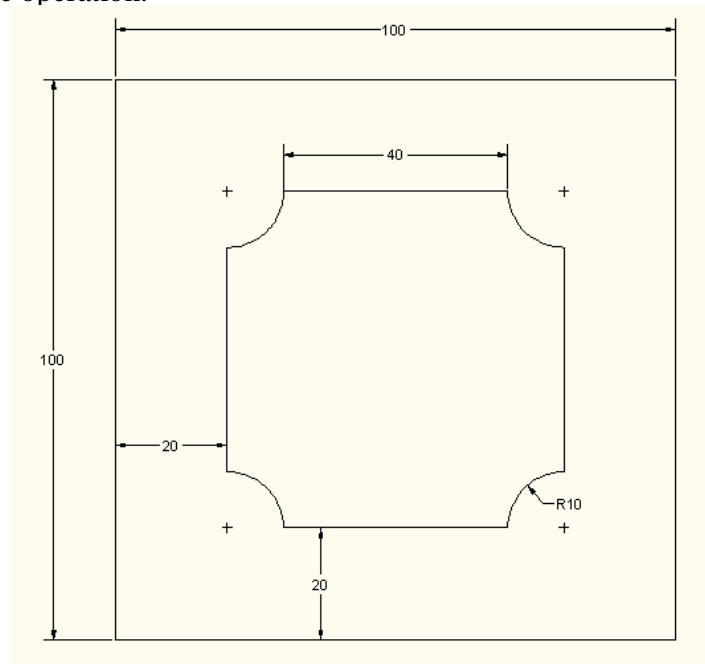

```
G91 G28  
Z0  
G28 X0 Y0  
M05  
M30
```

RESULT

Thus the part program was written and simulated for given job.

LINEAR INTERPOLATION BILLET SIZE (100x100x10 Z=-10)

AIM

To write the part programming and simulation them to the given milling job.

TOOLS AND EQUIPMENTS

1. CNC simulation software
2. CNC milling software
3. Software Pentium IV

PROCEDURE

1. To write the program for given job.
2. To type G and M CODES.
3. To give the tool size and stock dimensions.
4. Finally to run the machine to the operation.

PROGRAM

```
G21 G94
G91 G28
Z0
G28 X0 Y0
M06 T1 M03
S1500G90
G00 X20 Y20
G00 Z5
G01 Z-0.5 F30 G01
X80 Y20 F50G01
X80 Y80 F50G01
X20 Y80 F50G01
X20 Y20 F50G91
G28 Z0 G28
X0 Y0M05
M30
```

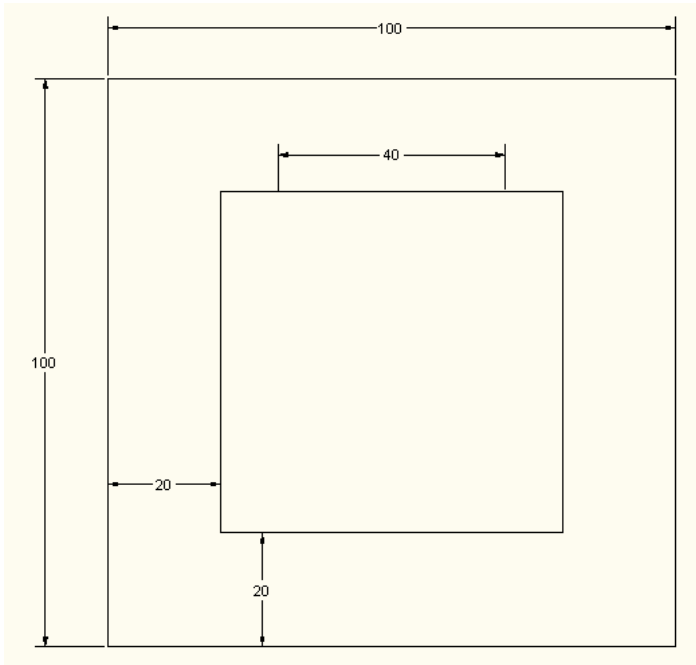

RESULT

Thus the part program was written and simulated for given job.

MILLING CIRCLE

BILLET SIZE (100x100x10 Z=-10)

```
G21 G94
G91 G28
Z0
G28 Y0 X0
M06 T1 M03
S1500G90
G00 X25 Y50 Z5
G01 Z-1 F100 G02
X25 I25 G00 Z5
G91
G28 Z0 Y0 X0
M05
M30
```

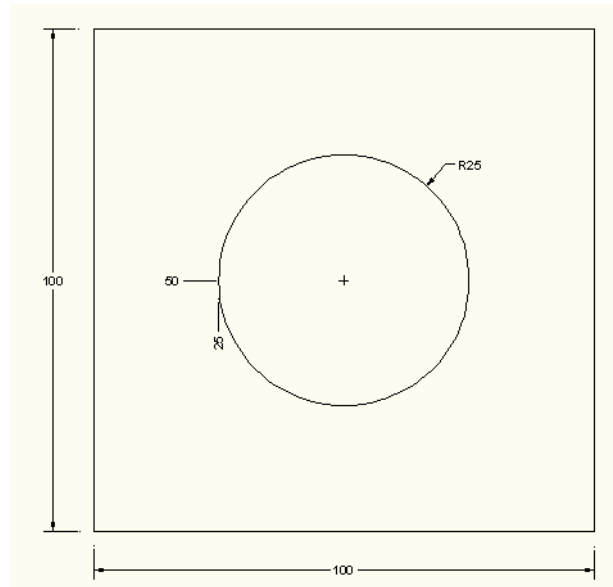

G-CODES

G21 – Input In mm
G94 – Feed/Min
G91 – Incremental Mode
G28 X Y Z – Return To Reference Point
G90 – Absolute Mode
G00 X Y – Positioning Rapid Traverse
G01 – Linear Interpolation
G03 – Circular Interpolation CCW
G02 – Circular Interpolation CW

M-CODES

M05 – Spindle Stop
M30 – Program End

PREPARATORY FUNCTION

(G -CODES)

G00- Fast transverse

G01- Linear interpolation

G02- Circular interpolation (c.w)

G03- Circular interpolation (c.c.w)

G04-Dwell

G20-Imperial (input in inches)

G21- Metric (input in mm)

G28- Go to reference

G40- Cutter compensation cancel

G41- Cutter compensation right

G42-Cutter compensation left

G50- Co-ordinate setting

G70-Finishing cycle

G71- Stock removal in turning

G72- Multiple facing

G73-Pattern repeating

G74- drilling

G76- Multiple thread

G81- Drilling cycle

G90-Turning cycle

G94- Facing cycle

G96- Constant surface

G97- Variable surface

G98- Feed per minute

G99- Feed per revolution

MISCELLANEOUS FUNCTION

(M - CODES)

- M00- Program stop
- M02- Optional stop
- M03- Program end
- M04- Spindle forward
- M05- Spindle stop
- M06- Tool change
- M08- Coolant on
- M09- Coolant off
- M10- Vice open
- M11- Vice close
- M62- Output 1ON
- M63- Output 2ON
- M64- Output1OFF
- M65- Output 2OFF
- M60- Wait input 1ON
- M67- Wait input 1OFF
- M76- Wait input 2OFF
- M77-Sub program call
- M98-Sub program exit
- M99- Sub program exit
- M30- Program and rewind

CNC VIVA QUESTIONS AND ANSWERS

1. What is NC?

Numerical control (NC) refer to control of a machine or a process using symbolic codes consisting of characters and numerals

2. List the Advantages of NC systems.

- Y Better control of the tool motion under optimum cutting conditions.
- Y Improved part quality and repeatability.
- Y Reduced tooling costs, tool wear, and job setup time.
- Y Reduced time to manufacture parts

3. What is Computer Numerical Control (CNC)?

Computer numerical control (CNC) is the numerical control system in which a dedicated computer is built into the control to perform basic and advanced NC functions.

4. List the Advantages of CNC systems.

CNC machines can be used continuously and only need to be switched off for occasional maintenance.

5. List the Disadvantages of CNC systems

CNC machines are generally more expensive than manually operated machines

6. Explain Direct Numerical Control (DNC).

In a Direct Numerical Control system (DNC), a mainframe computer is used to coordinate the simultaneous operations of a number NC machines.

7. Point out the application of CNC Machine Tools.

CNC was initially applied to metal working machinery: Mills, Drills, boring machines, punch presses etc and now expanded to robotics, grinders, welding machinery, EDM's, flame cutters and also for inspection equipment etc.

8. Explain about G codes.

G-code is the common name for the most widely used numerical control (NC) programming language, which has many implementations. Used mainly in automation, it is part

of computer-aided engineering. G-code is sometimes called G programming language

9. Mention few important G codes.

G00 - Positioning at rapid speed; Mill and Lathe
G01 - Linear interpolation (machining a straight line); Mill and Lathe
G02 - Circular interpolation clockwise (machining arcs); Mill and Lathe
G03 - Circular interpolation, counter clockwise; Mill and Lathe
G20 - Inch units; Mill and Lathe
G21 - Metric units; Mill and Lathe

10. What is the use M codes?

A word used to signal an action from a miscellaneous group of commands. M codes change cutting tools, turn on or turn off the coolant, spindle, or work piece clamps, etc.

11. Write some important M codes.

M00 - Program stop; Mill and Lathe
M01 - Optional program stop; Lathe and Mill
M02 - Program end; Lathe and Mill
M05 - Spindle off; Lathe and Mill

12. What is the use of box facing cycle?

Fanuc G94 facing cycle is used for simple facing (one-pass facing) however multiple passes are possible by specifying the Z-axis location of additional passes

13. What is the difference between G00 and G01 codes?

G00 - Positioning at rapid speed; Mill and Lathe
G01 - Linear interpolation (machining a straight line); Mill and Lathe

14. How to change the tool in CNC program?

M06 – Toolchange

15. How to change the tool speed in cnc lathe?

M03 - Spindle on clockwise; Lathe and Mill
M04 - Spindle on counterclockwise; Lathe and Mill

16. What is the difference between absolute and incremental system?

Absolute positioning means that the tool locations are always defined in relation to the zero point. Incremental positioning means that the next tool location must be defined with reference to the previous tool location.

17. What are the axes to be considered while writing program for cnc lathe?

X and Z Axis

18. What is the code for Threading cycle?

G92

19. What is the code for Incremental and absolute co-ordinate system?

G90 and G91

20. What is the code for coolant control?

- M7 - turn mist coolant on.
- M8 - turn flood coolant on.
- M9 - turn all coolant off.

21. what is use of dry run option?

A dry run (or a practice run) is a testing process where the effects of a possible failure are intentionally mitigated.