



**SRM VALLIAMMAI ENGINEERING COLLEGE**

(An Autonomous Institution)

SRM Nagar, Kattankulathur-603 203.

**DEPARTMENT OF MECHANICAL ENGINEERING**



**ME3467-Manufacturing Technology Laboratory-II**  
**(IV SEMESTER – MECHANICAL)**

**LABORATORY MANUAL**

**(REGULATION – 2023)**

**ACADEMIC YEAR 2024-25**

## SAFETY PRECAUTION

1. Always wear uniform, shoes and gloves for safety
2. Never operate any machines until you have been instructed properly
3. Always wear goggles to protect your eyes from flying chips.
4. Never hold the job when the machine runs.
5. Never give heavy cut on longer job
6. Never change the gear and belt when the machine is running
7. Always use the correct size spanner and tool for fitting and removing of tool
8. Never try to clear the chips when the machine is running
9. To prevent accident, clean the spilled oil and grease immediately
10. Always clear the area around the machine and machine tool surface
11. Leather shoes or boots with steel toes are recommended.
12. No open toed shoes or sandals are allowed in the shop.
13. Do not wear loose clothing. Cotton clothes are best to wear.
14. Remove all jewelry and tie back long hair.
15. Do not operate any machine equipment unless you have been instructed on its proper use and the safety risks involved with the machining operation.
16. Do not leave any machinery or power tools running and unattended.
17. Clean up metal shavings, oil, etc. from machine tools after use; pick up after yourself and return tools to their proper storage area.
18. Wear closed toe shoes and appropriate clothing.

19. Don't run, push or surprise other students. No horse play will be tolerated
20. Don't eat, drink, or smoke, in the laboratory
21. Always listen carefully to the teacher and follow instructions.
22. Do not run in the workshop, you could „bump“ into another pupil and cause an accident.
23. Know where the emergency stop buttons are positioned in the workshop. If you see an accident at the other side of the workshop you can use the emergency stop button to turn off all electrical power to machines.
24. Always wear an apron as it will protect your clothes and hold loses clothing such as ties in place..
25. When attempting practical work all stools should be put away.
26. Bags should not be brought into a workshop as people can trip over them.
27. When learning how to use a machine, listen very carefully to all the instructions given by the teacher. Ask questions, especially if you do not fully understand.
28. Do not use a machine if you have not been shown how to operate it safely by the teacher.
29. Always be patient, never rush in the workshop.
30. Always use a guard when working on a machine.
31. Keep hands away from moving/rotating machinery.
32. Use hand tools carefully, keeping both hands behind the cutting edge.
33. Report any damage to machines/equipment as this could cause an accident.

**OBJECTIVES:**

To study and acquire knowledge on various basic machining operations in special purpose machines and its applications in real life manufacture of components in the industry.

**LIST OF EXPERIMENTS:**

1. Contour milling using vertical milling machine
2. Spur gear cutting in milling machine
3. Helical Gear Cutting in milling machine
4. Gear generation in hobbing machine
5. Gear generation in gear shaping machine
6. Plain Surface grinding
7. Cylindrical grinding
8. Tool angle grinding with tool and Cutter Grinder
9. Measurement of cutting forces in Milling / Turning Process
10. CNC Part Programming

**TOTAL : 45 PERIODS**

**COURSE OUTCOMES:**

**Upon the completion of this course the students will be able to**

1. Prepare the work piece as per the given shape and size using machining processes such as surface grinding, tool grinding cylindrical grinding.
2. Create the work piece as per the given shape and size using machining process such as rolling, drawing, turning, shaping, drilling and milling.
3. Manufacture the gears using gear making machines and analyze the defects in the cast and machined components.

**S.No. NAME OF THE EQUIPMENT Qty.**

|                                |          |
|--------------------------------|----------|
| 1 Turret and Capstan Lathes    | 1No each |
| 2 Horizontal Milling Machine   | 2Nos.    |
| 3 Vertical Milling Machine     | 1No      |
| 4 Surface Grinding Machine     | 1No      |
| 5 Cylindrical Grinding Machine | 1No      |
| 6 Radial Drilling Machine      | 1No      |
| 7 Lathe Tool Dynamometer       | 1No      |
| 8 Milling Tool Dynamometer     | 1No      |
| 9 Gear Hobbing Machine         | 1No      |
| 10 Tool Makers Microscope      | 1No      |
| 11 CNC Lathe                   | 1No      |
| 12 CNC Milling machine         | 1No      |
| 13 Gear Shaping machine        | 1No      |
| 14 Centerless grinding machine | 1No      |
| 15 Tool and cutter grinder     | 1No      |

**CO - PO and CO - PSO MAPPING**

| ME3467  | PROGRAM OUTCOMES |   |   |   |   |   |   |   |   |    |    |    | PSOs |   |   |
|---------|------------------|---|---|---|---|---|---|---|---|----|----|----|------|---|---|
|         | 1                | 2 | 3 | 4 | 5 | 6 | 7 | 8 | 9 | 10 | 11 | 12 | 1    | 2 | 3 |
| CO1     | 3                |   |   |   |   |   | 1 |   | 2 |    |    | 1  | 1    | 2 | 2 |
| CO2     | 3                |   |   |   |   |   | 1 |   | 2 |    |    | 1  | 1    | 2 | 2 |
| CO3     | 3                |   |   |   |   |   | 1 |   | 2 |    |    | 1  | 1    | 2 | 2 |
| Average | 3                |   |   |   |   |   | 1 |   | 2 |    |    | 1  | 1    | 2 | 2 |

**CONTENT**

| <b>EX.<br/>NO.</b> | <b>DATE</b> | <b>EXERCISE</b> | <b>PAGE<br/>NO.</b> | <b>STAFF<br/>SIGN.</b> |
|--------------------|-------------|-----------------|---------------------|------------------------|
| 1.                 |             |                 |                     |                        |
| 2.                 |             |                 |                     |                        |
| 3.                 |             |                 |                     |                        |
| 4.                 |             |                 |                     |                        |
| 5.                 |             |                 |                     |                        |
| 6.                 |             |                 |                     |                        |
| 7.                 |             |                 |                     |                        |
| 8.                 |             |                 |                     |                        |
| 9.                 |             |                 |                     |                        |
| 10.                |             |                 |                     |                        |
| 11.                |             |                 |                     |                        |
| 12.                |             |                 |                     |                        |
| 13.                |             |                 |                     |                        |
| 14.                |             |                 |                     |                        |
| 15.                |             |                 |                     |                        |
| 16.                |             |                 |                     |                        |
| 17.                |             |                 |                     |                        |

|     |  |  |  |  |
|-----|--|--|--|--|
| 18. |  |  |  |  |
| 19. |  |  |  |  |
| 20. |  |  |  |  |
| 21. |  |  |  |  |
| 22. |  |  |  |  |

# I. MILLINGMACHINE

## INTRODUCTION:

Milling is the name given to the machining process in which the removal of metal takes place due to cutting action of a revolving cutter when the work is fed past it. The revolving cutter is held on a spindle and the work, clamped on the machine table, fed past the same. Milling is the cutting operation that removes metal by feeding the work against a rotating, cutter having single or multiple cutting edges. Flat or curved surfaces of many shapes can be machined by milling with good finish and accuracy. A milling machine may also be used for drilling, slotting, making a circular profile and gear cutting by having suitable attachments.

## WORKING PRINCIPLE IN MILLING:

The working principle, employed in the metal removing operation on a milling machine, is revolving multi teeth cutter mounted either on a spindle. The cutter revolves at a fairly high speed and the work fed slowly past the cutter. The work can be fed in a vertical, longitudinal or cross direction. As the work advances, the cutter-teeth remove the metal from the work surface to produce the desired shape. The work piece is holding on the worktable of the machine. The table movement controls the feed of work piece against the rotating cutter. The cutter is mounted on a spindle and revolves at high speed. Except for rotation the cutter has no other motion. As the work piece advances, the cutter teeth remove the metal from the surface of work piece and the desired shape is produced.

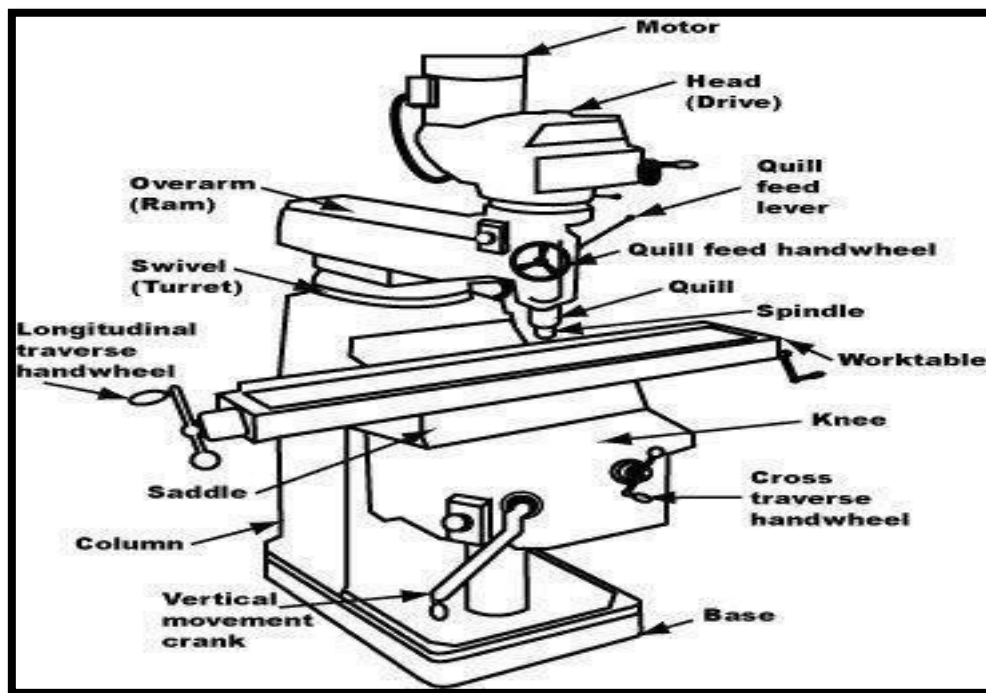

MILLING MACHINE



## TYPES OF MILLING MACHINES:

A large variety of different types of milling machines is available. The classification of these type machines can be done as follows:

1. Column and knee type milling machines
2. Fixed bed type or manufacturing type milling machines
3. Planer type milling machines
4. Production milling machines
5. Special purpose machines

## COLUMN AND KNEE TYPE MILLING MACHINES:

These machines are all general purpose machines and have a single spindle only. They are further classified as follows:

- (a) Hand milling machine
- (b) Plain or horizontal milling machine
- (c) Vertical milling machine and
- (d) Universal milling machine

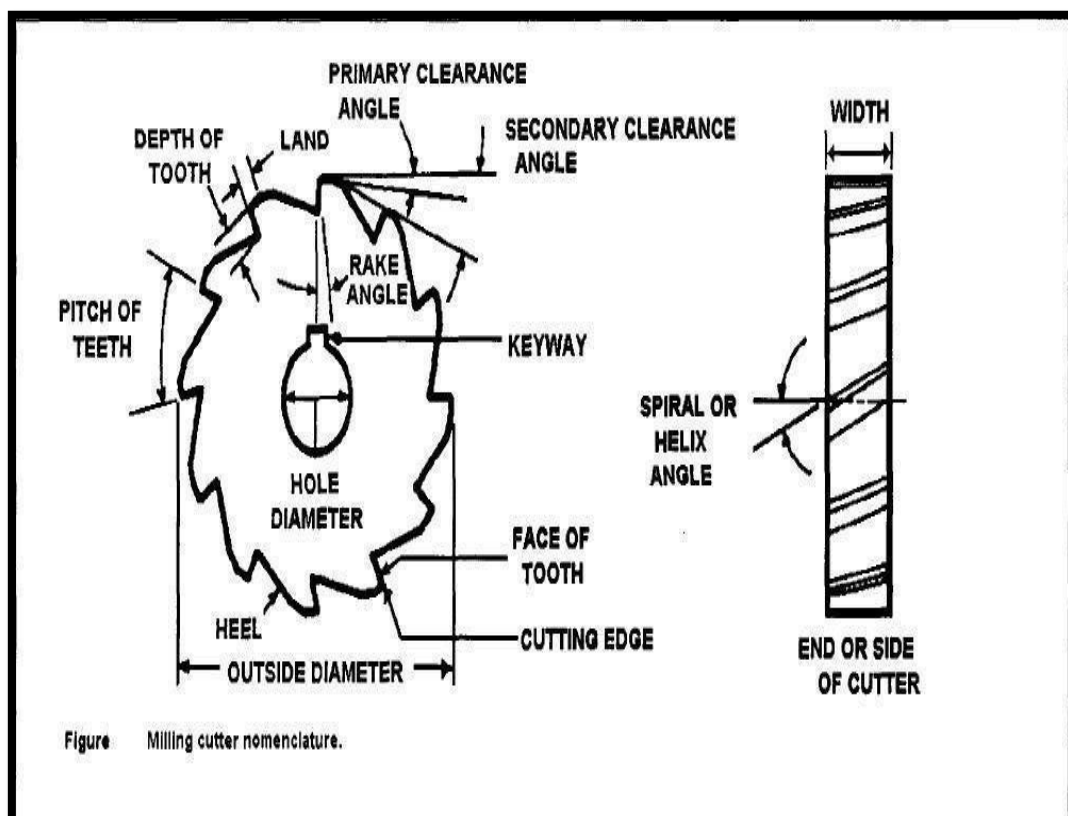

### **FIXED BED TYPE OR MANUFACTURING TYPR MILLING MACHINE:**

These machines, in comparison to the column and knee type, are more sturdy and rigid, and heavier in weight and larger in size. Their further classification is as follows:

- (a) Plain type (having single horizontal spindle).
- (b) Duplex head (having double horizontal spindles).
- (c) Triplex head (having two horizontal and one vertical spindle).
- (d) Rise and fall type (for profile milling)

### **PLANER TYPE MILLING MACHINES:**

They are used for heavy work. Up to a maximum of four tool heads can be mounted over it, which can be adjusted vertically and transverse directions. It has a robust and massive construction like a planar.

### **PRODUCTION MILLING MACHINES:**

They are also manufacturing machines but differ from the above described machines in that they do not have a fixed bed. They include following machines:

- (a) Rotary table or continuous type.
- (b) Drum type and
- (c) Tracer controlled

### **SPECIAL PURPOSE MILLING MACHINES:**

These machines are designed to perform a specific type of operation only. They include following machines:

- (a) Thread milling machine
- (b) Profile milling machine
- (c) Gear milling or gear hobbing machine
- (d) Cam milling machine
- (e) Planetary type milling machine
- (f) Double end milling machine
- (g) Skin milling machine and
- (h) Spar milling machine.

## **PLAIN OR HORIZONTAL MILLING MACHINE**

The vertical column serves as a housing for electrical, the main drive, spindle bearings, etc. The knee acts as support for the saddle, worktable and other accessories like indexing head, etc. Over arm provides support for the yoke which in turn, supports the free end of the arbor. The arbor carrying the cutter rotates about a horizontal axis. The table can be given straight motions in three directions; longitudinal, cross, vertical. For giving vertical movement to the table the knee it, together with the whole unit above it, slides up and down along the ways provide in front of the column. A brace is employed to provide additional support and rigidity to the arbor when a long arbor is used. Both hand power and power feeds can be employed for the work.

## **VERTICAL MILLING MACHINE:**

It derives its name from the vertical position of the spindle. This is available in both types; the fixed bed type as type as well as column and knee type. It carries a vertical column on a heavy base. The over arm in this machine is made integral with the column and carries a housing at its front. This housing called head can be of fixed type .In fixed type, the spindle always remains vertical and can be adjusted up and down.

The knee carries an enclosed screw jack, by means of which it is moved up and down along the parallel vertical guide ways provided on the front side of the column. The saddle is mounted on the knee and can be moved, along the horizontal guide ways provided on the knee, towards or away from the column. This enables the table to move in cross direction. The work gets up and down movement by the knee, cross movement by saddle and longitudinal movement by the table.

## **PARTS OF MILLING MACHINE:**

Main parts of the milling machines are similar; all these machine essentials consist of the following main parts:

### **1. BASE:**

It is a heavy casting provided at the bottom of the machine. It is accurately machined on both the top and bottom surfaces. It actually acts as a load bearing member for all other parts of the machine. Also it carries the screw jack which supports and moves the knee. In addition to this it also serves as reservoir for the coolant.

### **2. COLUMN:**

It is a very prominent part of the milling machine and is produced with enough care. On the front face of the column are made the vertical parallel ways in which the knee slides up and down. It carries the enclosed motor drive. Top of the column carries dovetail horizontal ways for the over arm.

### **3. KNEE:**

It is a rigid casting, which is capable of sliding up and down along the vertical ways on the front face of the column. This enables the adjustment of the table height. The adjustment is provided by operating the elevating jack, provided below the knee, by means of hand wheel or application of power feed. For efficient operation of the machine, rigidity of the knee and accuracy of its ways play an important role. On the front face of the knee two bolts are usually provided for securing the braces to it to ensure greater rigidity under heavy loads.

### **4. SADDLE:**

It is the intermediate part between the knee and the table and acts as a support for the latter. It can be adjusted crosswise, along the ways provided on the top of the knee, to provide cross feed to the table. As its top, it carries horizontal ways, along which moves the table during longitudinal traverse.

### **5. TABLE:**

It acts as a support for the work. It is made of cast iron, with its top surface accurately machined. Its top carries longitudinal cross T-slots to accommodate the clamping bolts for fixing the work or securing the fixtures. Also, the cutting fluid, after it is used, drains back to the reservoir through these slots and then the pipe fitted for this purpose. Longitudinal feed is provided to it by means of hand wheel fitted on one side of the feed screw. Cross feed is provided by moving the saddle and vertical feed by raising or lowering the knee.

### **6. OVERARM:**

It is the heavy support provided on the top of both plain and universal milling machine. It can slide horizontally, along the ways provided on the top of the column, and adjusted to a desired position in order to provide support to the projecting arbor by accommodating its free end in the yoke.

## 1. CONTOURMILLING USING VERTICAL MILLING MACHINE

### AIM:

To machine a groove in the given work piece using vertical milling machine.

### TOOLS REQUIRED:

1. Milling machine
2. Vernier caliper
3. Steel rule
4. Machine vice
5. Centre punch

### MATERIAL REQUIRED:

150 X 50 X 10 mm Cast Iron flat

### PROCEDURE

1. Check whether the machine is in proper condition.
2. Check whether the work piece which gives in suitable size.
3. The job is marked to the desired shape and punched.
4. Hold the work piece in the vice and fix the tool in the arbor in correct position and machine is started.
5. The minimum depth of cut is given and feed is given by reciprocating table.
6. Remove the job and check the dimensions.
7. Continue the steps to obtain required dimensions.

**DIAGRAM:**

VERTICAL MILLING

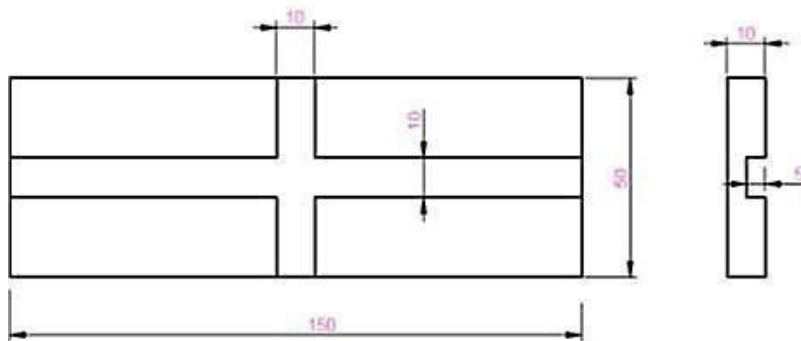

ALL DIMENSIONS ARE IN mm  
DO NOT SCALE

**RESULT:**

Thus the vertical milling operation was performed on the given work piece using vertical milling machine.

## 2. SPUR GEAR CUTTING IN MILLING MACHINE

### AIM:

To machine gear to the given module and number of teeth in the given work piece.

### TOOLS AND EQUIPMENTS REQUIRED:

1. Milling machine
2. Vernier caliper
3. Mandrel.

### PROCEDURE:

1. Calculate the gear tooth proportions.

Where,

$$\text{Blank diameter} = (Z + 2) m$$

$$\text{Tooth depth} = 2.25 m$$

$$\text{Tooth width} = 1.5708 m$$

Z = Number of teeth required

m = module

Indexing calculation

$$\text{Index crank movement} = 40 / Z$$

2. The dividing head and the tail stock are bolted on the machine table. Their axis must be set parallel to the machine table.
3. The gear blank is held between the dividing head and tailstock using a mandrel. The mandrel is connected with the spindle of dividing head by a carrier and catch plate.
4. The cutter is mounted on the arbor. The cutter is centered accurately with the gear blank.
5. Set the speed and feed for machining.
6. For giving depth of cut, the table is raised till the periphery of the gear blank just touches the cutter.
7. The micrometer dial of vertical feed screw is set to zero in this position.
8. Then the table is raised further to give the required depth of cut.
9. The machine is started and feed is given to the table to cut the first groove of the blank.
10. After the cut, the table is brought back to the starting position.
11. Then the gear blank is indexed for the next tooth space.
12. This is continued till all the gear teeth are cut.

## CALCULATION:

$$Z = \text{No. of teeth} = 23$$

$$m = \text{module} = 2 \text{ mm}$$

$$\begin{aligned} \text{Blank Diameter} &= (Z + 2) * m \\ &= (23 + 2) * 2 \\ &= 50 \text{ mm} \end{aligned}$$

$$\begin{aligned} \text{Tooth Depth} &= 2.25m \\ &= 2.25 * 2 \\ &= 4.5 \text{ mm} \end{aligned}$$

### Indexing Calculation

$$= 40 / Z$$

$$= 40 / 23$$

$$= 1.739$$



**DIAGRAM:**

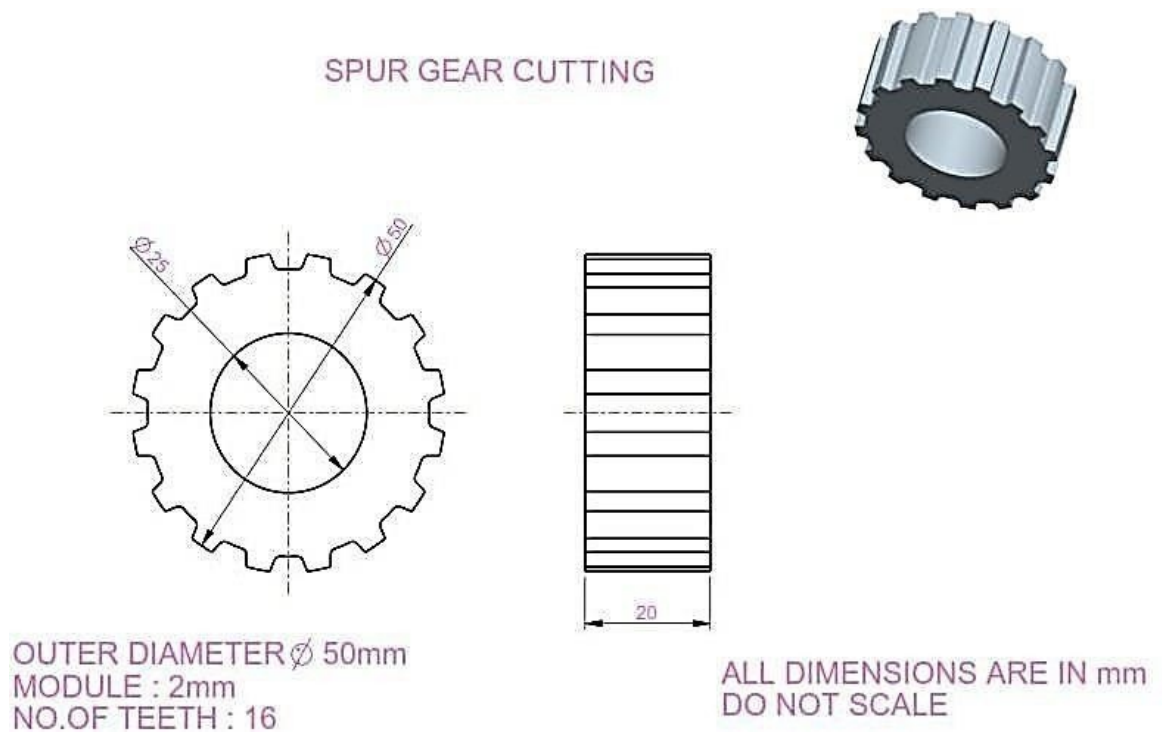

**RESULT:**

Thus the required gear is machined using the milling machine to the required number of teeth

### 3. HELICAL GEAR CUTTING IN MILLING MACHINE

#### AIM:

To make a helical gear from a CI blank using milling machine

#### MATERIAL REQUIRED:

Cast iron blank of  $\Phi 50\text{mm}$

#### TOOLS REQUIRED:

1. Turning tool
2. Milling cutter (2mm module)
3. Vernier caliper (0-150mm)
4. Drilling tool  $\Phi 10\text{mm}, \Phi 20\text{mm}$
5. Mandrel  $\Phi 20\text{mm}$
6. Spanner
7. Gear tooth Vernier

#### FORMULA:

Outer diameter =  $(N+2) M$ ,

Module =  $OD / (N+2)$ ,

No .of teeth =  $(OD/M) - 2$

N- Number of teeth

M=module

OD= outer diameter

#### PROCEDURE:

1. Turn the given CI blank to required diameter in Centre lathe.
2. Drill a hole in the blank of diameter equal to mandrel size.
3. Fix the blank between two centers of the dividing head using mandrel.
4. Set the milling cutter on the machine spindle and select the suitable speed.
5. Raise the table (knee) vertically up until blank touches the cutter.
6. Calculate depth of cut and indexing calculation from module & number of teeth.
7. Give the depth of cut by raising the knee up.
8. According to index calculation set the dividing head.
9. Switch on the spindle and feed the blank against the rotating cutter by reciprocating the table
10. Move the index arm on the index plate according to the calculated number of holes.
11. Feed the blank against the rotating cutter to cut the next tooth.
12. Repeat the same for remaining teeth

**DIAGRAM:**

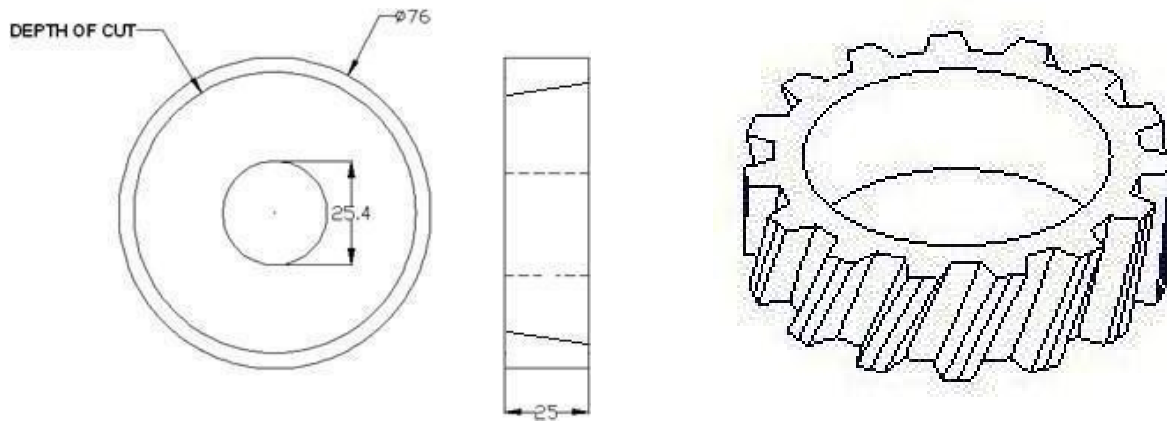

### MODEL CALCULATION FOR HELICAL GEAR:

|                       |                              |
|-----------------------|------------------------------|
| No of teeth (z)       | =30                          |
| Module (m)            | =2mm                         |
| External dia.of blank | = (z+2)*m<br>= (30+2)*2=64   |
| Depth of cut          | =2.25*m<br>=2.25*2<br>=4.5mm |

The indexing crank rotation = one complete rotation and move arm holes in 33 concentric circle.

### RESULT:

Thus the spur gear has made by using milling machine to the required size.

## II. STUDY OF GEAR HOBBIINGMACHINE

### INTRODUCTION:

Gear Hobbing is a continuous generative process in which the tooth flanks of the constantly moving work piece are formed by equally spaced cutting edges of the hob. The profile produced on the gear is a curve comprising of a number of flats, varying with the number of flutes in the hob which pass a given tooth during the generative movement. Every hob tooth which contacts the gear along line of action produces one enveloping cut. Like the straight flank of the hob tooth, the individual cut is straight and in tangent plane to the involutes of the tooth flanking.

### WORKING PRINCIPLE OF OPERATION:

The generative process requires an accurate relationship between various elements of the machine in order to achieve the desired results. The work table rotates in a definite relationship with the rotation of the hob. This relation is timed by index change gears. For hobbing helical gears, the rotation of the work table is slightly advanced or retarded in relation to the rotation of the axial feed screw by means of another set of change gears called different change gears. The direction of feed of the hob relative to the work piece can be achieved in any of the three ways, but these basic feeds can be combined to form other permutations.

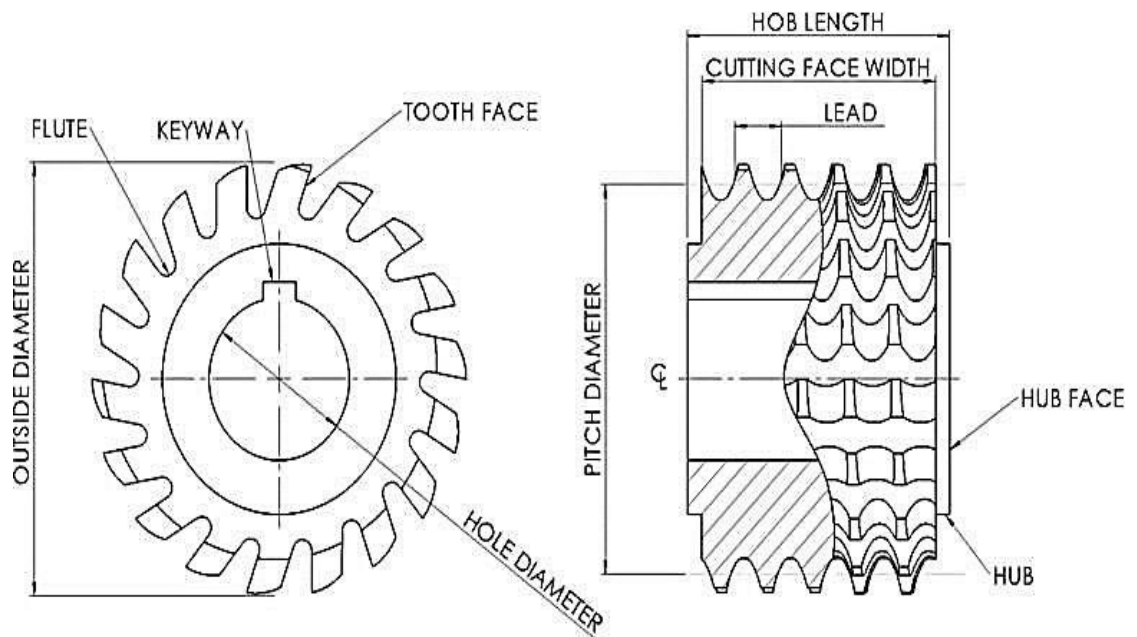

**HOB Nomenclature**

## **TYPES OF HOBGING:**

The hobbing process is classified in to different types according to the directions of feeding the hob for gear cutting.

### **1. HOBGING WITH AXIALFEED.**

This type of feeding method is mainly used for cutting spur and helical gears, as explained in the previous article. It involves moving the hob towards the gear blank or the blank towards the hob to bring the two in such a relative position that the required tooth depth is blank towards obtained .this is followed by feeding the rotating positions that the required tooth depth is obtained. This is followed by feeding the rotating hob along the face of the blank parallel to the axis of the latter. This feeding can be from below the blank upwards or from above the blankupwards.

### **2. HOBGING WITH RADIALFEED.**

This method of hob in-feed is mainly used for cutting worm wheels. In this method the hob and gear blank are set with their axes normal tom each other. The gear blank continues to rotate at a set speed about its vertical axis and the rotating hob is given in-feed in a radial, direction towards the centre of blank rotation.

An important point to be noted here is that while the use of radial in feed results in higher rate of production the accuracy of the tooth profile produced is of low order.

### **3. HOBGING WITH TANGENTIALFEED:**

It is yet another common method used for cutting teeth on worm wheels. In this method, the worm wheel blank is rotated in a vertical plane about horizontal axis. The hob is held with its axis horizontal but at right angles to the axis of the blank. The hob in feed is tangential to the blank face and hence, the name ‘tangential feeding’

## **ADVANTAGES:**

1. It is a faster and continues process. Hence, quite economical as compared to other generative processes
2. It enables a high rate of production.
3. The gear teeth generated through this process are very accurate.
4. The process can be adopted with equal advantage for both medium and large batch productions.
5. Hobbing machines, their setting and operation are simpler.

#### **4. GEAR GENERATION IN HOBGING MACHINE**

**AIM:**

To generate a spur gear using Gear Hobbing machine to the given dimensions.

**TOOLS REQUIRED:**

1. Vernier caliper
2. Mandrel
3. Drill bit  $\phi 25\text{mm}$

**PROCEDURE:**

1. The given job is turned to required outer diameter
2. The given job is held firmly in the mandrel against the gear Hobber
3. The position of work table is adjusted, so that the job and cutter are on the same line
4. The machine is switched ON and the table is fed parallel to the cutter.
5. The feed is given longitudinally again and again, this procedure is repeated for completion of 16teeth.

**DIAGRAM:**

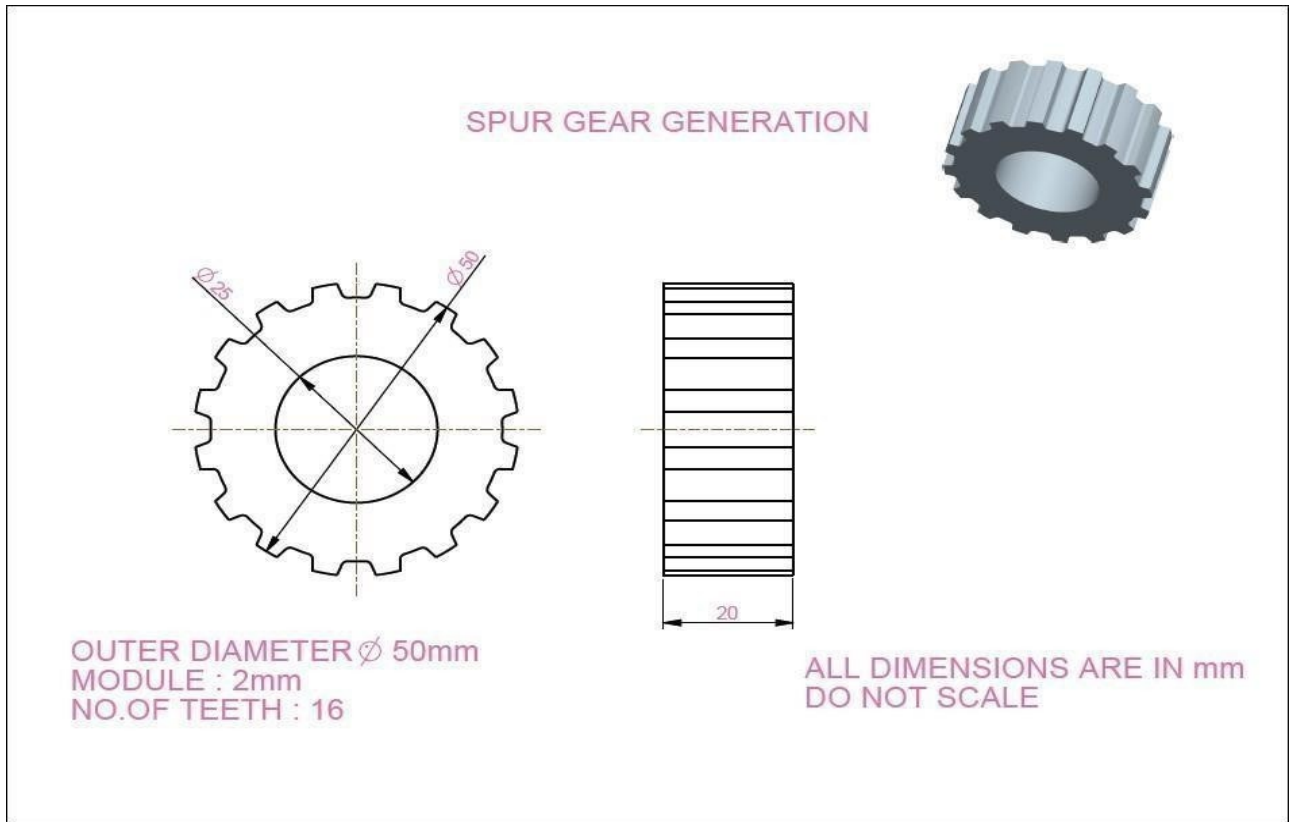

**RESULT:**

Thus the spur gear is generated using Gear Hobbing machine



### III. STUDY OF GEARSHAPING MACHINE

**AIM:**

To study the working of gear shaping machine

**INTRODUCTION**

A gear shaper is a machine tool for cutting the teeth of internal or external gears. The name shaper relates to the fact that the cutter engages the part on the forward stroke and pulls away from the part on the return stroke, just like the clapper box on a planer shaper.

The cutting tool is also gear shaped having the same pitch as the gear to be cut. However number of cutting teeth must be less than that of the gear to be cut for internal gears. For external gears the number of teeth on the cutter is limited only by the size of the shaping machine. For larger gears the blank is sometimes gashed to the rough shape to make shaping easier.

The principal motions involved in rotary gear shaper cutting are of the following

1. Cutting Motion: The downward linear motion of the cutter spindle together with the cutter.
2. Return Stroke: The upward linear travel of the spindle and cutter to withdraw the latter to its starting position.
3. Indexing Motion: Slow speed continuous rotation of the cutter spindle and work spindle to provide circular feed, the two speeds being regulated through the change gears such that against each rotation of the cutter the gear blank revolves through  $n/N$  revolution, where "n" is the number of teeth of the cutter, and "N" is the number of teeth to be cut on the blank.
4. Completion of Cutting Operation: The indexing and reciprocating motions continue until the required number of teeth to the required depth are cut all along the periphery of the gear blank

**WORKING PRINCIPLE OF OPERATION**

Gear shaping is similar to the rack type cutting process, excepting that, the linear type rack cutter is replaced by a circular cutter as indicated in figure, where both the cutter and the blank rotate as a pair of spur gears in addition to the reciprocation of the cutter. Generation method is characterized by automatic indexing and ability of a single cutter to cover the entire range of number of teeth for a given combination of module and pressure angle and hence provides high productivity and economy.

The gear type cutter is made of HSS and possesses proper rake and clearance angles. The additional advantages of gear shaping over rack type cutting are:

- Separate indexing is not required at all
- Straight or helical teeth of both external and internal spur gears can be produced with high accuracy and finish
- Productivity is also higher

**Result:**

Thus the working of gear shaping machine has been studied

## 5. GEAR GENERATION IN GEAR SHAPING MACHINE

### AIM:

To make a Spur Gear form a CI blank using Gear Shaping machine.

### MATERIAL REQUIRED:

Cast iron blank of  $\Phi 50\text{mm}$

### TOOLS REQUIRED:

1. Vernier caliper
2. Mandrel
3. Drill bit  $\phi 25\text{mm}$

### PROCEDURE:

1. The given job is turned to required outer diameter
2. The given job is held firmly in the mandrel against the Gear Shaping machine.
3. The position of work table is adjusted, so that the job and cutter are on the same line
4. The machine is switched ON and the table is fed parallel to the cutter.
5. The feed is given longitudinally again and again, this procedure is repeated for completion of 16teeth.

**DIAGRAM:**

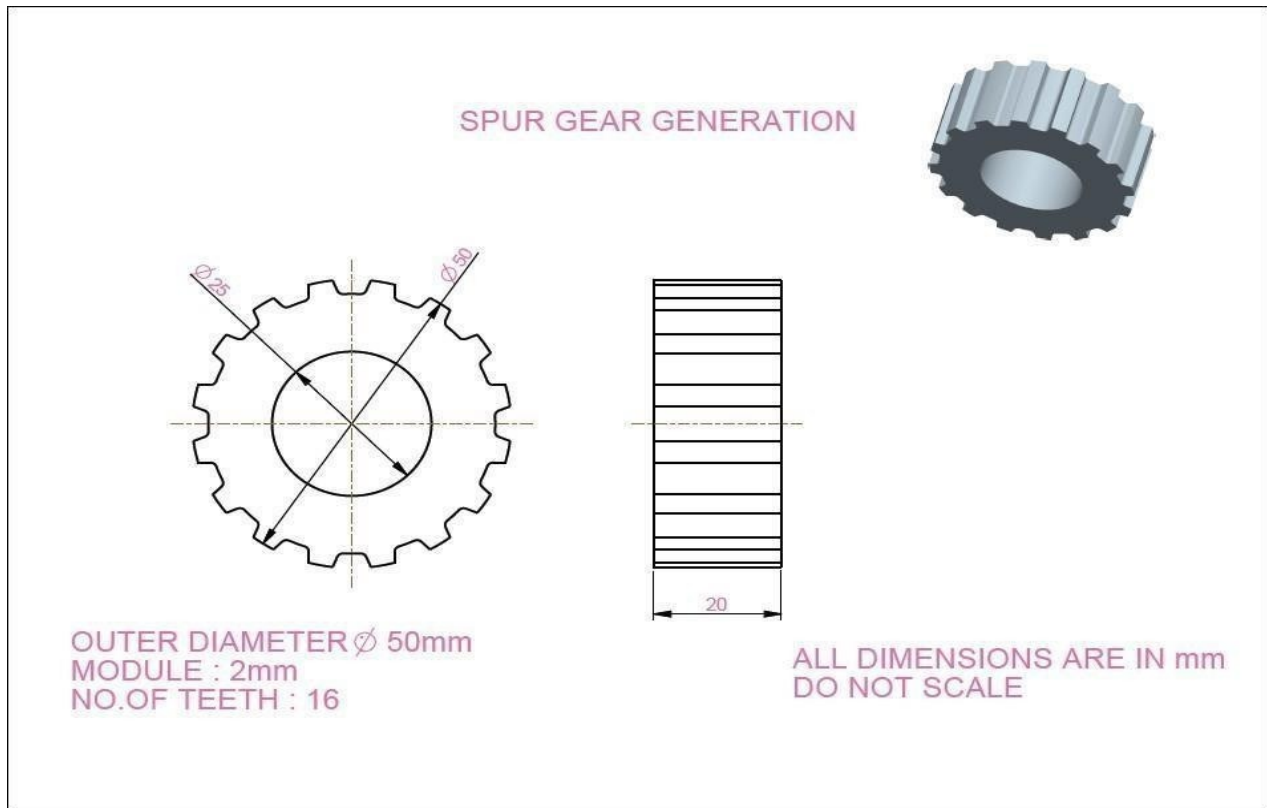

**RESULT:**

Thus the Spur Gear is Generated using Gear Shaping machine

## IV. STUDY OF GRINDING MACHINE

### INTRODUCTION:

Grinding is metal cutting operation performed by means of a rotating abrasive wheel that acts as a tool. This is used to finish work pieces which must show a high surface quality, accuracy of shape and dimension. The art of grinding goes back many centuries. Columns and statues were shaped and finished with a globular stone which abraded the surface.

Mostly grinding is a finishing operation because it removes comparatively little metal 0.25 to 0.50 mm in most operations and the accuracy is in the order of 0.000025 mm. many different types of grinding machines have now been developed for handling various kinds of work to which the grinding process is applicable. A grinding machine is a machine tool used for grinding, which is a type of machining using an abrasive wheel as the cutting tool. Each grain of abrasive on the wheel's surface cuts a small chip from the work piece via shear deformation.

The grinding machine consists of a power driven grinding wheel spinning at the required

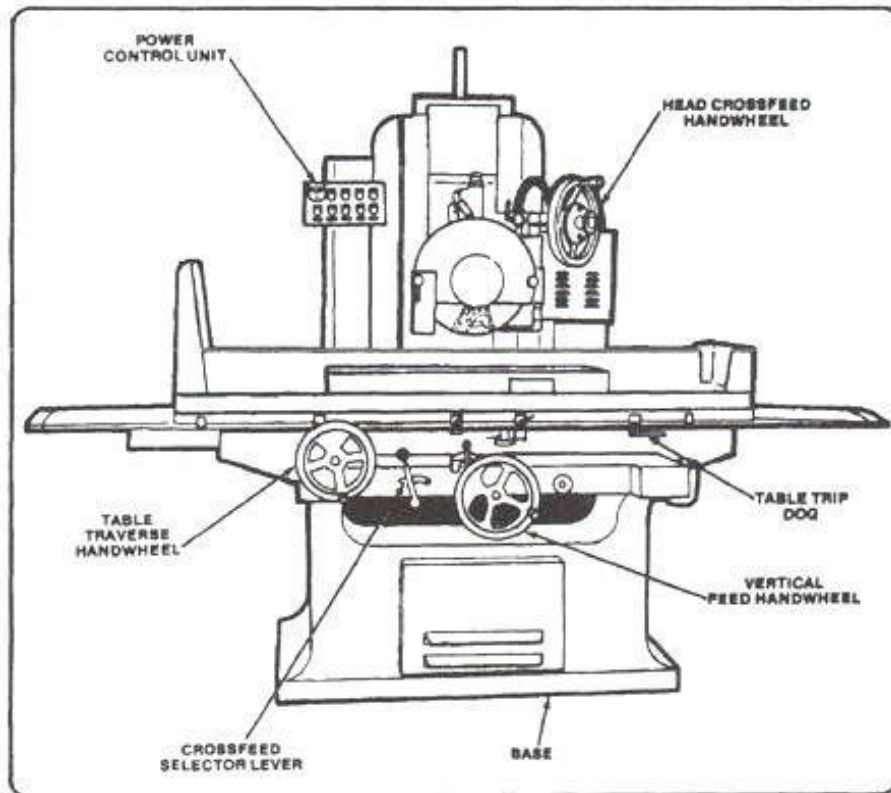

Figure 5-6 Reciprocating surface grinding machine

speed and a bed with a fixture to guide and hold the work-piece. The grinding head can be controlled to travel across a fixed work piece or the work piece can be moved whilst the grind head stays in a fixed position. Very fine control of the grinding head or table position is possible using a Vernier calibrated hand wheel, or using the features of numerical controls. Grinding machines remove material from the work piece by abrasion,

which can generate substantial amounts of heat; they therefore incorporate a coolant to cool the work piece so that it does not overheat and go outside its tolerance. The coolant also benefits the machinist as the heat generated may cause burns in some cases.

## **KINDS OF GRINDING:**

1. Rough or non-precision grinding
2. Precision grinding

## **ROUGH OR NON PRECISION GRINDING**

The common forms of rough grinding are snagging and offhand grinding, where the work is held in the operator's hand. The work is pressed hard against the wheel, or vice versa. The accuracy and surface finish obtained of secondary importance.

## **PRECISION GRINDING**

This is concerned with producing good surface finish and high degree of accuracy. Yarn wheel or work both are guided in precise paths.

## **CENTRELESS GRINDERS**

Centre less grinding is a method of grinding exterior cylindrical tapered and formed surfaces on work pieces that are not held and rotated on centers. The principle elements of an external center less grinder are the grinding wheel, regulating or back up wheel and the work rest. Both wheels are rotated in the same direction. The work rest is located between the wheels. The work is placed upon the work rest and the latter together with the regulating wheel, is fed forward forcing the work against the grinding wheel. Centre less grinding may be done in one of the three ways

- a) Through feed
- b) In feed
- c) End feed

## **SURFACE GRINDERS:**

Surface grinding machines are employed to finish planes on flat surfaces. They are also capable of grinding irregular, curved, convex and concave surfaces. Conventional surface grinders may be divided into two classes: one class has reciprocating tables for work ground along straight lines, while the other covers the machines with rotating work tables continuous rapid grinding. Surface grinders may also are classified according to whether they have horizontal or vertical grinding wheel spindles.

### **Horizontal Spindle Reciprocating Table Surface Grinder:**

- **Base:** The base has a column at the back for supporting the wheel head. The base also contains the drive mechanism.
- **Table:** The table is fitted to the saddle on carefully machined ways. It reciprocates along ways to provide the longitudinal feed. If slots are provided in the table surfaces for clamping work pieces directly on the table or for clamping grinding fixtures or a magnetic chuck;
- **Wheel Head:** The wheel heads are mounted on the column secured on the base. It has ways for the vertical slide which can be raised or lowered with the grinding wheel only manually by rotating a hand wheel to accommodate work pieces of different heights and to set the wheel for depth of cut.
- **Operation:** The work piece reciprocates under the wheel, and the wheel on the table beds axially between passes to produce a fine flat surface. Wheel down feed determines depth of cut and final height of the piece from the table to the wheel. The amount of feed must only be equal to a few hundredths of millimeters. For example steel is rough ground with a depth of cut between 0.02 and 0.05 mm and finish ground with a depth of cut of 0.005 to 0.01 mm.

## 6. PLAIN SURFACE GRINDING

### AIM:

To finish the surface of the given specimen using surface grinding machine

### TOOLS REQUIRED:

1. Magnetic power machine table
2. Vernier caliper(0-150mm)
3. Micrometer(0-25mm)
4. Aluminum oxide grinding wheel.

### MATERIAL REQUIRED:

100mmX50mmX6mm M.S. flat

### PROCEDURE

1. Check the dimensions of the given flat.
2. Mark the dimensions as per the given drawing using steel rule and scriber.
3. Clamp the work piece by means of a magnetic chuck.
4. Then start the machine with slow speed
5. The table is started to Reciprocate.
6. Then feed is given with minimum depth of cut.
7. Remove the job and check the dimensions.
8. Continue the steps to achieve the required dimensions.

**DIAGRAM:**

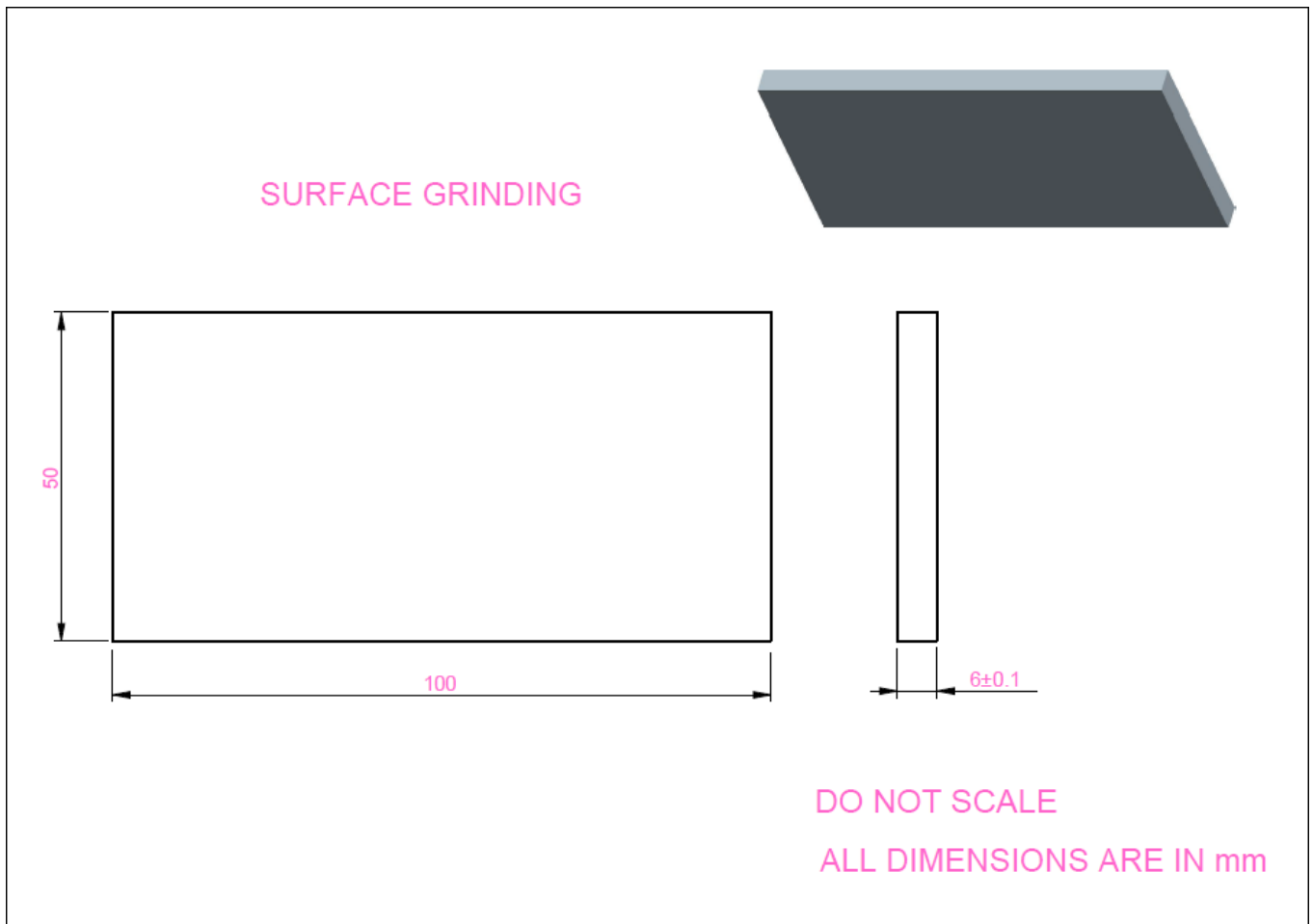

**RESULT:**

Thus the surface grinding operation is performed on the work piece.

## 7. CYLINDRICAL GRINDING

### AIM:

To grind a given cylindrical work piece by using cylindrical grinding machine as per dimensions in the drawing

### TOOLS REQUIRED:

1. Dog carrier
2. Vernier caliper
3. Vernier height gauge
4. Chuck key
5. Double ended spanner
6. V-block
7. Punch and Hammer

### MATERIAL SUPPLIED:

1.  $\Phi 25\text{mm} \times 100\text{mm}$  cylindrical work piece
2. Material mild steel

### PROCEDURE:

1. Check the dimensions of the given workpiece.
2. Mark the dimensions as per the given drawing using steel rule and scribe.
3. Make drilling on both side of the marked center.
4. Hold the job in dog carrier and between the centers to remove the excess material from the workpiece.
5. Grind the work piece of given dimension.
6. Check the dimension of the job.



**DIAGRAM:**

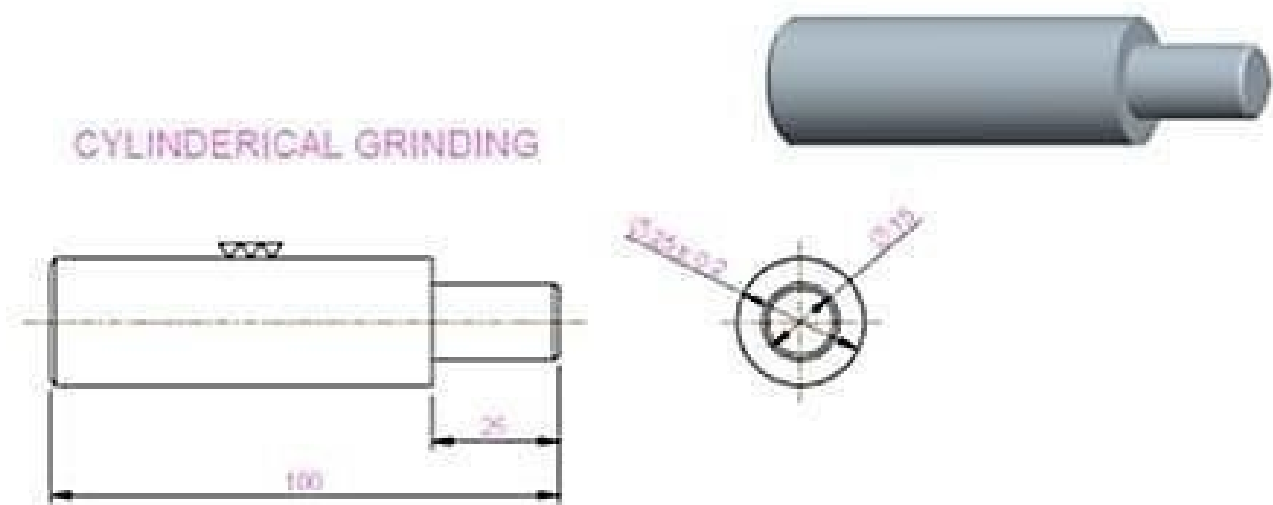

ALL DIMENSIONS ARE IN mm  
DO NOT SCALE  
CHAMFER 1X45°

**RESULT:**

Thus the cylindrical grinding is operation performed on the work piece.

## 8. TOOL ANGLE GRINDING WITH TOOL AND CUTTER GRINDER

### AIM:

To perform the angle grinding with tool and cutter grinder on the given work piece for the given dimensions.

### REQUIREMENTS:

1. Tool Grinding Machine
2. Work Piece
3. Grinding Wheel

### PROCEDURE:

1. At first work piece is placed in the magnetic chuck.
2. The work piece should be light weight so that it cannot be removed from the magnetic chuck easily.
3. Various arrangements regarding the positions of work piece is done.
4. Grinding wheel and grinding spindle are kept in position with the workpiece.
5. Before switching on the motor, necessary steps should take. For proper grinding process wheel speed, work speed, transverse speed of the wheel in feed, area of contact is to be noted.
6. While running the area of contact is adjusted accordingly to the spindle in order to remove the surface.
7. It is done slowly to remove the materials on all surface of the work piece

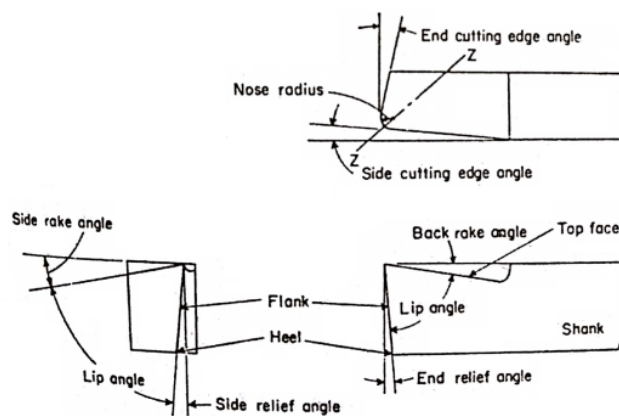

Figure 1: Tool nomenclature and tool angles  
(sec. 3.50 for tool signature)

### RESULT:

To Study about the angle grinding with tool and cutter grinder on the given work piece for the given dimensions.

## 9. MEASUREMENT OF CUTTING FORCES IN MILLING/ TURNING PROCESS

### AIM:

To measure the cutting forces for the given cutting conditions

### TOOLS AND EQUIPMENTS REQUIRED:

1. Lathe
2. Lathe Tool Dynamometer

### PROCEDURE:

1. The Lathe Tool Dynamometer is initially set to zero reading.
2. The known depth of cut is given and take the readings of  $P_x$  and  $P_z$  force components from the Lathe Tool Dynamometer.
3. Calculate the resultant cutting force
$$P = \sqrt{P_x^2 + P_z^2}$$
4. Repeat the same procedure to get few more readings and calculate the mean cutting force.
5. Repeat the same procedure for different depth of cuts

### NOTE:

1.  $P_z$  – the main or tangential component, determines the torque on main drive mechanism, the deflection of the tool and the required power. This component acts in the direction of the cuttingspeed.
2.  $P_x$  – the axial component, acts in the direction of the tool traverse and it is at right angles to  $P_z$ . It contributes very little to the power consumption.
3.  $P_y$  – the radial component, acts along the tool shank and perpendicular to the other two components. It has no share in the powerconsumption

DIAGRAM:

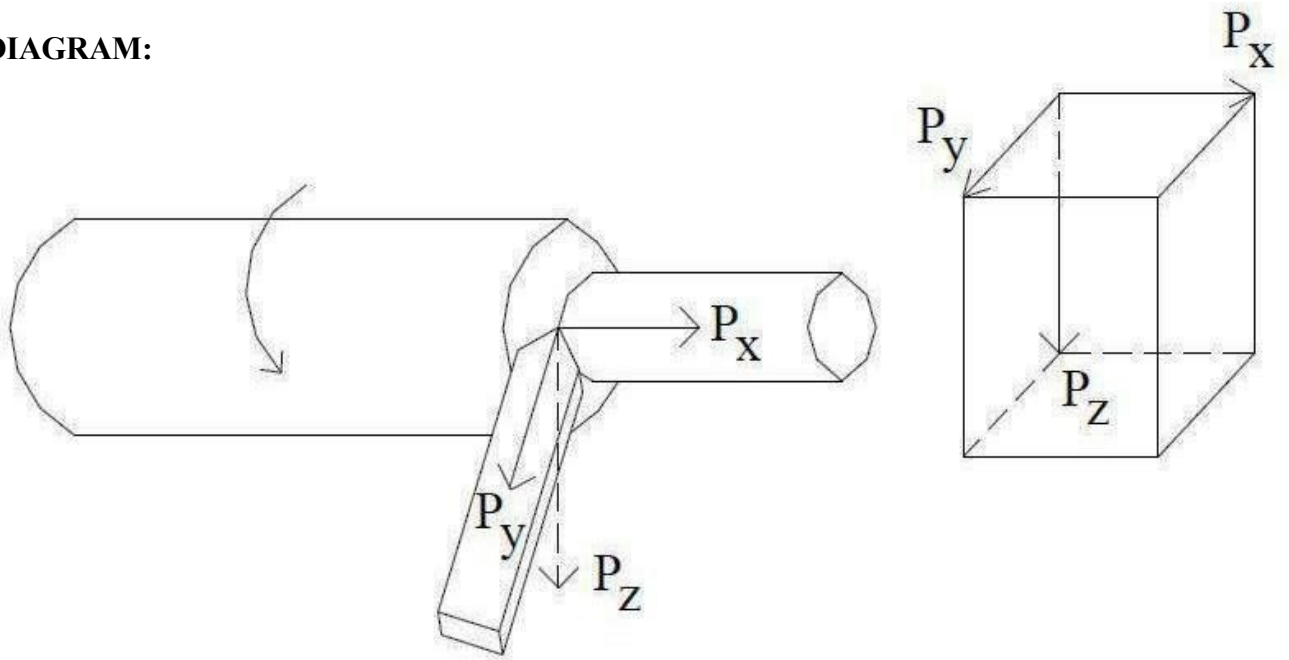

TABULATION :

| S.No | Depth of Cut (mm) | Horizontal Component (Kg) | Vertical Component (Kg) | Resultant $P = \sqrt{Px^2 + Pz^2}$ (Kg) | AVERAGE (Kg) |
|------|-------------------|---------------------------|-------------------------|---|--------------|
| 1.   | 0.25              |                           |                         |   |              |
| 2.   | 0.50              |                           |                         |   |              |
| 3.   | 0.75              |                           |                         |   |              |

**RESULT:**

Thus the cutting forces are measured for different depth of cuts

## V. CNC PARTPROGRAMMING

### INTRODUCTION

The part program is a sequence of instructions, which describe the work, which has to be done on a part, in the form required by a computer under the control of a numerical control computer program. It is the task of preparing a program sheet from a drawing sheet. All data is fed into the numerical control system using a standardized format. Programming is where all the machining data are compiled and where the data are translated into a language which can be understood by the control system of the machine tool.

The machining data is as follows

- (a) Machining sequence classification of process, tool start up point, cutting depth, tool path,
- (b) Cutting conditions, spindle speed, feed rate, coolant, etc.
- (c) Selection of cutting tools.

While preparing a part program, need to perform the following steps

- (a) Determine the startup procedure, which includes the extraction of dimensional data from part drawings and data regarding surface quality requirements on the machined component.
- (b) Select the tool and determine the tool offset.
- (c) Set up the zero position for the workpiece.
- (d) Select the speed and rotation of the spindle.
- (e) Set up the tool motions according to the profile required.
- (f) Return the cutting tool to the reference point after completion of work.
- (g) End the program by stopping the spindle and coolant.

The part programming contains the list of coordinate values along the  $X$ ,  $Y$  and  $Z$  directions of the entire tool path to finish the component. The program should also contain information, such as feed and speed. Each of the necessary instructions for a particular operation given in the part program is known as an NC word. A group of such NC words constitutes a complete NC instruction, known as block. The commonly used words are  $N$ ,  $G$ ,  $F$ ,  $S$ ,  $T$ , and  $M$ . The same is explained later on through examples.

Hence the methods of part programming can be of two types depending upon the two techniques as below

- (a) Manual part programming, and
- (b) Computer aided part programming.

### **Manual Part Programming**

The programmer first prepares the program manuscript in a standard format. Manuscripts are typed with a device known as flexo writer, which is also used to type the program instructions. After the program is typed, the punched tape is prepared on the flexo writer. Complex shaped components require tedious calculations. This type of programming is carried out for simple machining parts produced on point-to-point machine tool. To be able to create a part program manually, need the following information

- (a) Knowledge about various manufacturing processes and machines.
- (b) Sequence of operations to be performed for a given component.
- (c) Knowledge of the selection of cutting parameters.
- (d) Editing the part program according to the design changes.
- (e) Knowledge about the codes and functions used in part programs.

### **Computer Aided Part Programming**

If the complex-shaped component requires calculations to produce the component are done by the programming software contained in the computer. The programmer communicates with this system through the system language, which is based on words. There are various programming languages developed in the recent past, such as APT (Automatically Programmed Tools), ADAPT, AUTOSPOT, COMPAT-II, 2CL, ROMANCE, SPLIT is used for writing a computer programme, which has English like statements. A translator known as compiler program is used to translate it in a form acceptable to MCU. The programmer has to do only following things

- (a) Define the work part geometry.
- (b) Defining the repetition work.
- (c) Specifying the operation sequence.

Over the past years, lot of effort is devoted to automate the part programme generation. With the development of the CAD (Computer Aided Design)/CAM (Computer Aided Manufacturing) system, interactive graphic system is integrated with the NC part programming. Graphic based software using menu driven technique improves the user friendliness. The part programmer can create the geometrical model in the CAM package or directly extract the geometrical model from the CAD/CAM database. Built in tool motion commands can assist the part programmer to calculate the tool paths automatically. The programmer can verify the tool paths through the graphic display using the animation function of the CAM system. It greatly enhances the speed and accuracy in tool path generation.

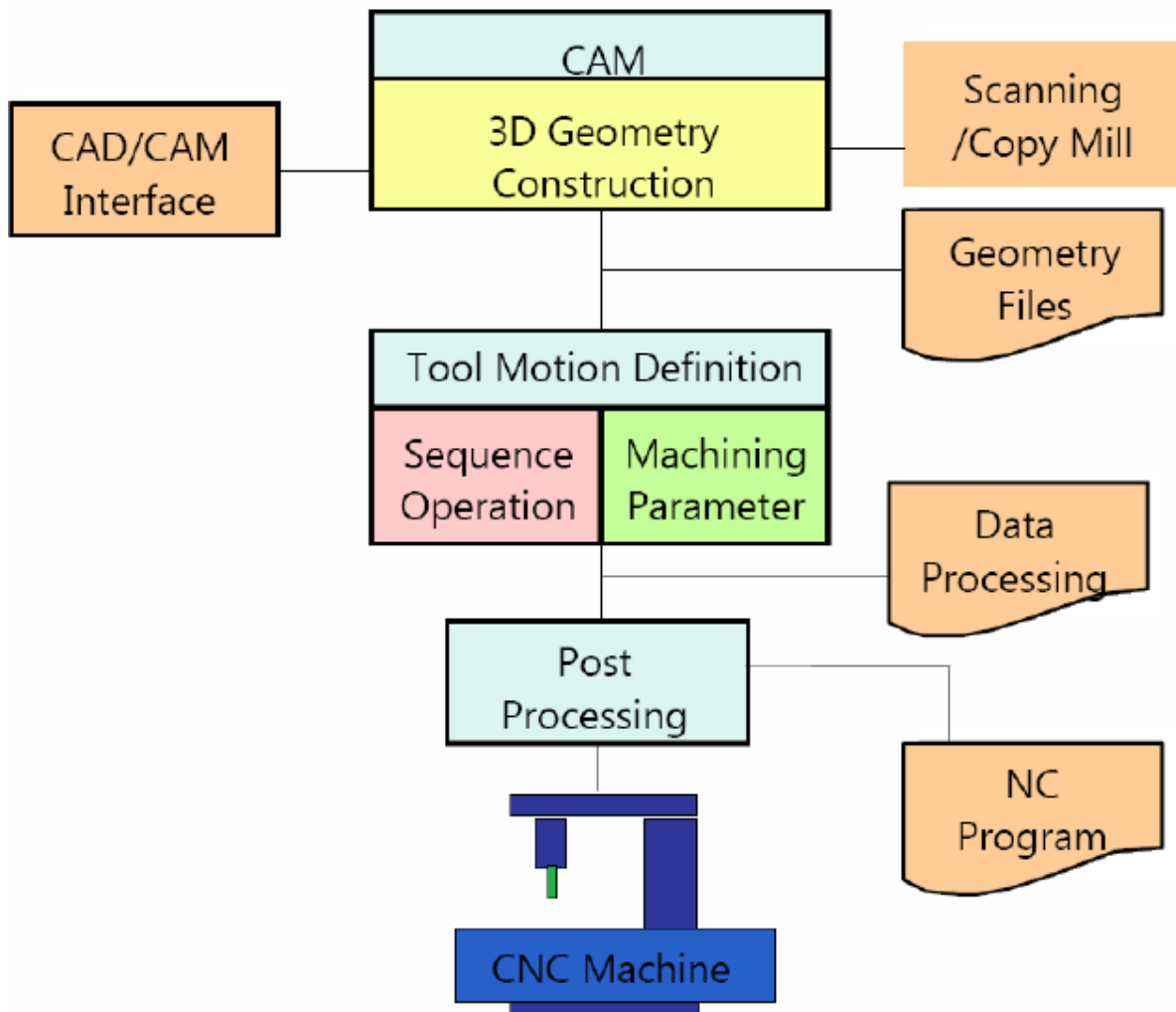

## STANDARD G AND M CODES

The most common codes used when programming NC machines tools are G-codes (preparatory functions), and M codes (miscellaneous functions). Other codes such as *F*, *S*, *D*, and *T* are used for machine functions such as feed, speed, cutter diameter offset, tool number, etc. G-codes are sometimes called cycle codes because they refer to some action occurring on the *X*, *Y*, and/or *Z*-axis of a machine tool. The G-codes are grouped into categories such as Group 01, containing codes G00, G01, G02, G03, which cause some movement of the machine table or head. Group 03 includes either absolute or incremental programming. A G00 code rapidly positions the cutting tool while it is above the work piece from one point to another point on a job. During the rapid traverse movement, either the *X* or *Y*-axis can be moved individually or both axes can be moved at the same time. The rate of rapid travel varies from machine to machine. The total numbers of these codes are 100, out of which some of important codes are given as under with their functions:



### **G-Codes (Preparatory Functions)**

G00 Rapid positioning  
G01 Linear interpolation  
G02 Circular interpolation clockwise (CW)  
G03 Circular interpolation counterclockwise (CCW)  
G20 Inch input (in.)  
G21 Metric input (mm)  
G24 Radius programming  
G28 Return to reference point  
G29 Return from reference point  
G32 Thread cutting  
G40 Cutter compensation cancel  
G41 Cutter compensation left  
G42 Cutter compensation right  
G43 Tool length compensation positive (+) direction  
G44 Tool length compensation minus (-) direction  
G49 Tool length compensation cancels  
G53 Zero offset or M/c reference  
G54 Settable zero offset  
G84 canned turn cycle  
G90 Absolute programming  
G91 Incremental programming

### **M-Codes (Miscellaneous Functions)**

M or miscellaneous codes are used to either turn ON or OFF different functions, which control certain machine tool operations. M-codes are not grouped into categories, although several codes may control the same type of operations such as M03, M04, and M05, which control the machine tool spindle. Some of important codes are given as under with their functions

M00 Program stop  
M02 End of program  
M03 Spindle start (forward CW)  
M04 Spindle start (reverse CCW)  
M05 Spindle stop  
M06 Tool change  
M08 Coolant on  
M09 Coolant off  
M10 Chuck - clamping  
M11 Chuck - unclamping  
M12 Tailstock spindle out  
M13 Tailstock spindle in  
M17 Tool post rotation normal  
M18 Tool post rotations reverse  
M30 End of tape and rewind or main program end  
M98 Transfer to subprogram  
M99 End of subprogram



## 10. FACING AND TURNING

**AIM:**

To machine a given work piece for given dimension using turning and facing operation.

**PROGRAM:**

```
[BILLET X32 Z70
G21 G98
G28 U0 W0
M06 T3
M03 S1500
G00 X28 Z1
G94 X0 Z-0.5 F80
Z-1
Z-2
G00 X32 Z1
G90 X28 Z-50 F100
X27.5
X27
X26.5
X2
X25
G28 U0 W0
M05
M30
```

**DIAGRAM**

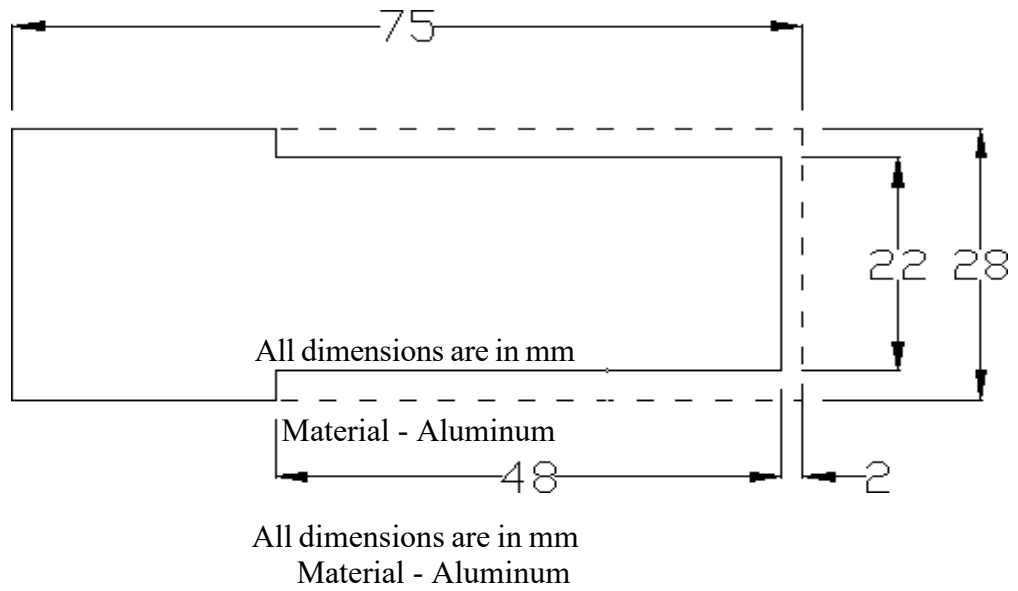

**RESULT:**

Thus the given work piece was machined for the required dimensions.

## 11. STEPTURNING

### AIM:

To machine a given work piece for given dimension using step turning operations.

### PROGRAM:

```
[BILLET X28 Z75
N10 G21 G98
N20 G28 U0 W0
N30 M06 T1
N40 M03 S1500
N50 G00 Z2
N60 G00 X28
N70 G94 X-1Z-.5F1.2          FACING
      Z-1
      Z-1.5
      Z-2
N80 G71U0.5R1                CANNED CYCLE
N90 G71 P100 Q140 U0.1 W0.1F100
N100 G01X20 Z0              CYCLE START
N110 G01 X20 Z-25
N120 G01 X25 Z-25
N130 G01 X25Z-50
N140 G01X28 Z-50           CYCLE END
N150 G28 U0 W0
N160 M05
N170 M30
```



**DIAGRAM**

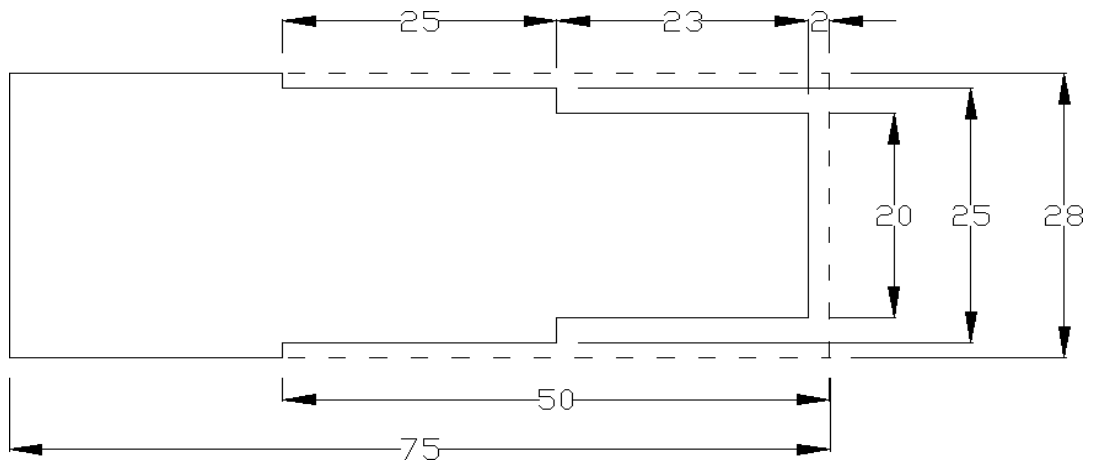

All dimensions are in mm  
Material - Aluminum

## 12. TAPERTURNING

**AIM:**

To machine a given work piece for given dimension using taper turning operations.

**PROGRAM:**

```
[BILLET X28 Z75
N10 G21 G98
N20 G28 U0 W0
N30 M06 T1
N40 M03 S1500
N50 G00 Z2
N60 G00 X28
N70 G94 X-1Z-.5F100          FACING
      Z-1
      Z-1.5
      Z-2
N80 G71U0.5R1                CANNED CYCLE
N90 G71 P100 Q120 U0.1 W0.1F100
N100 G01 X20 Z0
N110 G01 X20 Z-25
N120 G01 X28 Z-50
N130 G28 U0 W0
N140 M05
N150 M30
```



**DIAGRAM:**

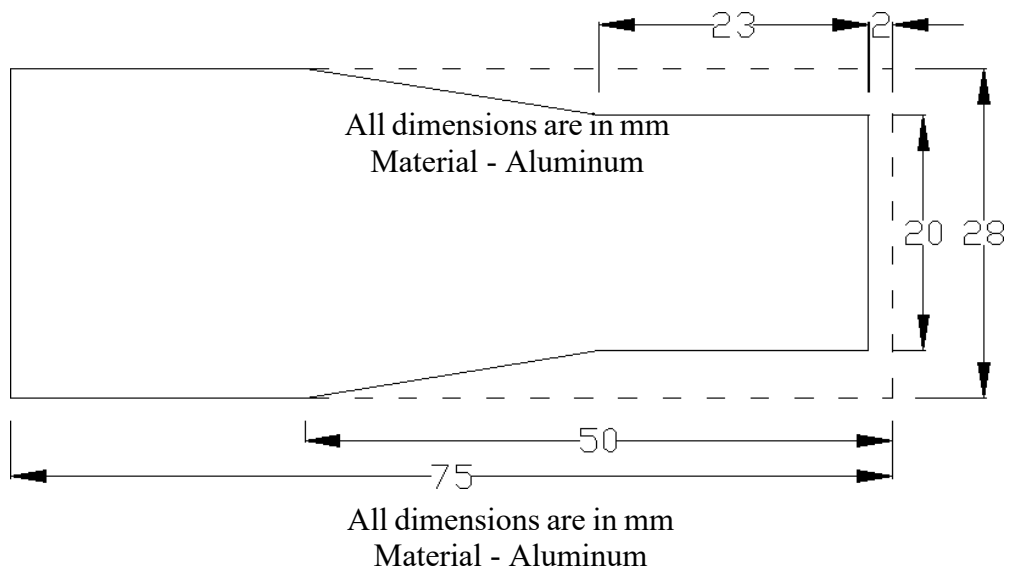

### 13. CONTOURMILLING

**AIM:**

To machine a given work piece for the given dimension using contour milling

**PROGRAM:**

**Example:1**

```
[BILLET X100 Y100 Z10  
[EDGE MOVE X-50 Y-50  
[TOOL DEF T1 D6  
G21 G94  
G91 G28 Z0  
G28 X0 Y0  
M06 T01  
M03 S1500  
G90 G00 X-25 Y-25 Z5  
G01 Z-1 F30  
G01 X25 Y-25  
G01 X25 Y15  
G03 X15 Y25 R10  
G01 X-15Y25  
G02 X-25 Y15 R10  
G01 X-25 Y-25  
G00 Z5  
G91 G28 Z0  
G28 X0 Y0  
M05  
M30
```

**Example :2**

```
G17 G71 G90 G94 G54; (Parameters  
Setting)  
T2 L90; (Home position)  
G00 D2 Z50 M3 S700 X10 Y-25;  
(Position of tool)  
G01 Z-1.5; (Position of cut)  
G01 X4 F100 M8; (Cuttingslat)  
G00 Z100 M9; (Final position of tool)  
M30; (Main programme end)
```

# DIAGRAMS

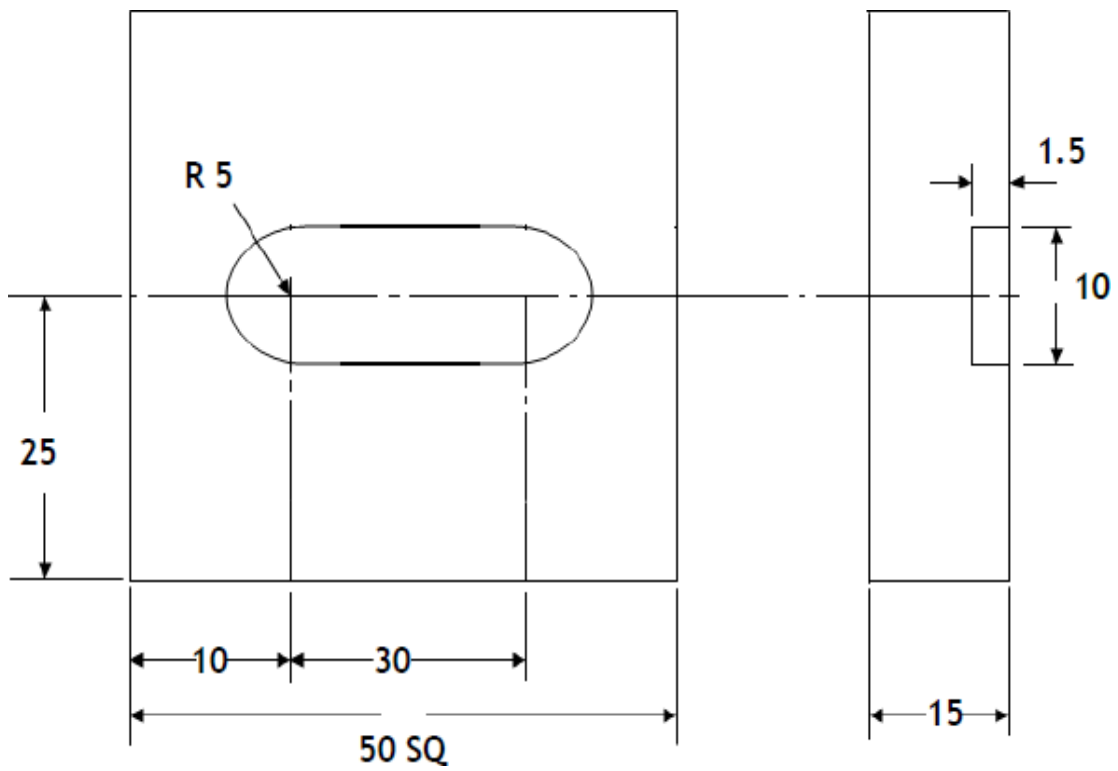
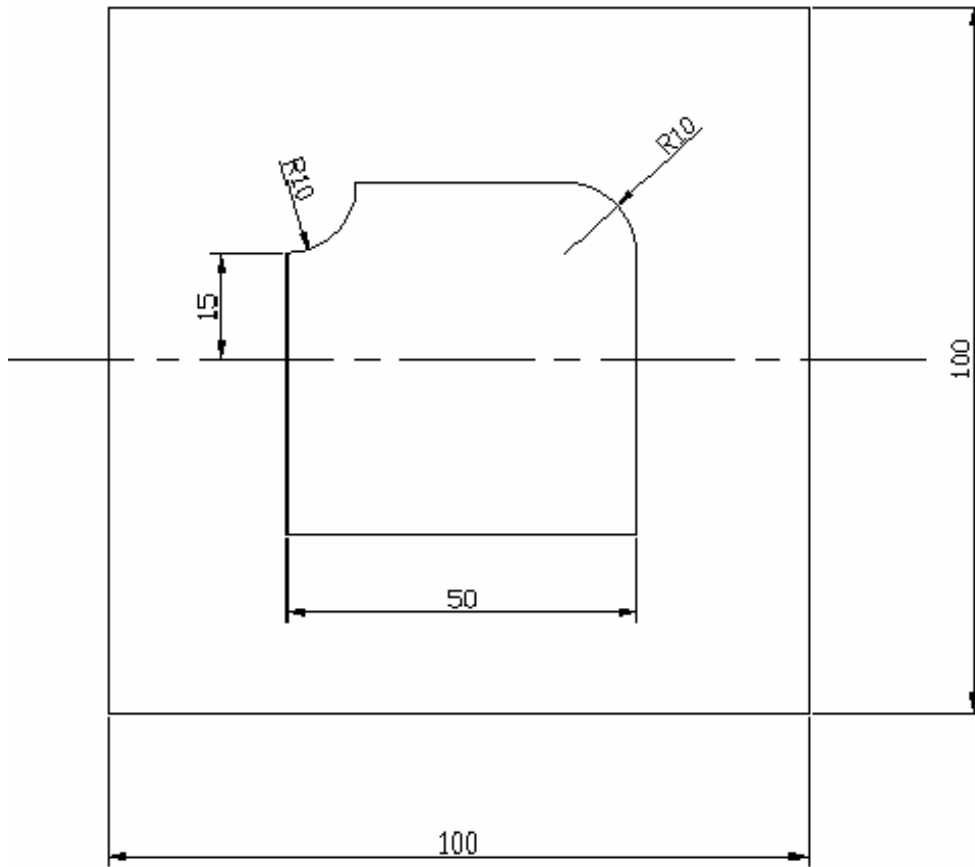

All dimensions are in mm  
Material - Aluminum



## VIVA QUESTIONS

### **I. DRILLING & BORING**

**1. Classify drilling machines.**

Portable drilling machine, Sensitive drilling machine, upright drilling machine, radial drilling machine, Multi spindle drilling machine, Automatic drilling machine and Deep hole drilling machine.

**2. What are the various types of drilling machines**

Plain type, Semi-universal type, Universal type.

**3. What is gang drilling machine?**

When a number of single spindle with essential speed and feed are mounted side by side on one base and have common worktable, is known as gang drilling machine.

**4. Specify a drilling machine.**

Maximum size of the drill in mm that the machine can operate. Table size of maximum, dimensions of a job can mount on a table in square meter. Maximum spindle travel in mm. Number of spindle speed and range of spindle speeds in r.p.m.

**5. List any four machining operations performed on a drilling machine** Drilling, countersinking, Tapping, Trepanning.

**6. What is meant by Reaming?**

Reaming is sizing and finishing the already drilled hole. The tool used for reaming is known as reamer.

**7. What is the use of a tapping tool?**

A tap is a tool which is used for making internal threads in a machine component.

**8. What are the types of boring machines?**

Horizontal, Vertical, Precision, Jig boring machine.

**9. What are the types of horizontal boring machine?**

Table type, floor type, planer type, multi-spindle type.

**10. What are the three types of vertical boring machine?**

Vertical boring mill, Vertical turret lathe boring machine, Vertical precision boring machine.

**11. Name the various operations performed on a horizontal boring**

Machine Boring, facing, drilling and reaming.

**12. List out the possible operations on a vertical boring machine.**

Cylindrical, taper turning, boring, turning plane surface and forming.

**13. Specify the importance of jig boring machine.**

A jig boring machine is a precision boring machine used for boring accurate holes at proper center to center distances.

**14. What is super finishing?**

The process of obtaining a surface of the highest class of finish is known as super finishing.

**15. What is meant by honing?**

An abrading process of finishing previously machined surfaces.

**II. MILLING**

**1. What are the specifications of milling machine?**

The table length and width, Maximum longitudinal cross and vertical travel of the table, number of spindle speeds and feeds, Power of driving motor, Floor space and net weight.

**2. Classify milling machine.**

1. Column and knees type – a. plain milling machine, b. Vertical milling machine, c. Universal milling machine, d. Ram- type milling machine, e. Universal milling machine.
2. Bed-Type milling machine – a. simplex milling machine b. duplex milling machine c. Triplex milling machine.
3. Plano-type milling machine.
4. Special purpose milling machine – a. Rotary table milling machine b. Drum milling machine c. Profile milling machine.

**3. List the principle parts of horizontal or plain milling machine.**

Base, column, knee, saddle, table, overarm and arbor.

**4. How universal milling machine differs from universal milling machine?**

This is a modified form of a plain milling machine. It is provided with two spindles, one of which is in the horizontal plane while the other is carried by a universal swiveling head.

**5. Classify bed type milling machine.**

Simplex, duplex and triplex machine.

**6. What are the various types of special purpose milling machines?**

Rotary table or continuous milling machine, Drum type milling machine Profile or contour milling machine.

**7. List the various types of milling attachments.**

Vertical milling attachment, universal milling attachment, High speed milling attachment, Rotary attachment, slotting attachment, Rack milling attachment, Universal spiral milling machine.

**8. What are the advantages of up milling process?**

It does not require a backlash eliminator. Safer operation due to separating forces between cutter and work.

**9. Write any ten nomenclature of plain milling processes.**

Body of cutter, cutting edge, face fillet, Gash, Lead, Land, outside diameter, Root diameter, Cutter Angles.

**10. Classify peripheral milling processes.**

Up milling or conventional milling, down milling or climb milling.

**11. What are the advantages of down milling process?**

Cutter with higher rake angles can be used. This reduces power requirements. Cutter wear is less because chip thickness is maximum at the start of the cut.

**12. Define “face milling”.**

Face milling is the operation performed by a milling cutter to produce flat machined surfaces perpendicular to the axis of rotation.

**13. What is meant by plain or slab milling?**

Plain or slab milling is the operation of producing flat horizontal surface parallel to the axis of the cutter using a plain or slab milling cutter.

**14. List out various milling operations.**

Plain milling, Face milling, Angular milling, Straddle milling, Gang milling, Form milling, End milling, T-slot milling, Gear cutting.

**15. Define Straddle and Gang milling.**

Straddle milling operation is the production of two vertical flat surfaces on the both sides of the job by using two side milling cutters which are separated by collars. Gang milling is the production of many surfaces of a job simultaneously by feeding the table against a number of required cutters.

**16. What is meant by term indexing?**

Indexing is the process of dividing the periphery of a job in to equal number of divisions.

**17. What are the three types of dividing heads?**

Plain or simple dividing head, Universal dividing head, Optical dividing head.

### **18. What is cam milling?**

Cam milling is the operation of producing cams in a milling machine by the use of a universal dividing head and a vertical milling attachment.

### **19. What are the specifications of milling machine?**

The table length and width, Maximum longitudinal cross and vertical travel of the table, number of spindle speeds and feeds, Power of driving motor, Floor space and net weight.

## **III. GRINDING**

### **1. What is the process of self-sharpening of the grinding wheel?**

During machining, the blunt abrasive grains will be released from the wheel surface. In their place, new abrasive grains project from the surface of the wheel.

This process is called self-sharpening of the grinding wheel.

### **2. State the purpose of grinding.**

To remove small amount of metal from work pieces and finish then to close tolerances. To obtain a better surface finish.

### **3. Classify grinding machine.**

Precision grinders, Rough grinders, cylindrical grinders, internal grinders, surface grinders, tool grinders, Special purpose grinding machines.

### **4. What is meant by center less grinding?**

Center less grinding is performed on work pieces which do not have centers, such as pistons, valves, rings, tubes, balls, wrist pins, drills, bushings, shafts etc. Center less grinding can be done on both external and internal cylindrical surfaces.

### **5. What are the various methods of center less grinding?**

Through feed, In feed, End feed.

### **6. What are the different methods used in gear grinding process?**

Forming process, Generating process.

### **7. What are the purposes of gear grinding process?**

To improve the surface finish of teeth.

To increase the accuracy of teeth.

To remove the distortion due to heat treatment process.

### **8. List the various gear finishing process.**

Gear shaving, Gear Burnishing, Gear grinding. Gear lapping.



## **IV. GEAR GENERATING**

### **1. What do you understand by gear generating?**

Gear generating process is based on the fact that any two motives gear of the some module will mesh exactly. In this process one of the gears act as cutter. Due to relative rolling motion of the cutter and blank, gear teeth are generated.

### **2. Distinguish between the forming and generating methods?**

Single point Tool (Forming): Here the tool is a single point tool. The job should be indexed for every tooth; The tool is fixed.

Pinion type cutter (Generating): Here the tool is also a gear made of hard steels, (Used as cutter). The job is not indexed for every tooth. The cutter as well as the blank rotates simultaneously meshing with each other.

### **3. Factors affecting geometrical accuracy of the circular component .in shape?Geometrical accuracy of the circular component depends upon: a) The trueness of the work piece rotation, b) Parallelism of the tool movement with the work spindle axis, c) The effect of the toolwear.**

### **4. Write the advantages of gear shaping (Generating)?**

The advantages of Gear shaping are: a) with a particular module of DP cutter, gears having the same module of DP but different number of teeth can be cut accurately, b) Quicker and economical, c) Only one cutter is used for cutting all spur gears of same pitch, d) Both internal and external gears can be cut.

### **5. What is the main disadvantage of gear shaping?**

The main disadvantage of gear shaping is that Worm and worm wheels cannot be generated on a gear shaper.

### **6. When do you prefer shaping process for generating a gear?**

Gear shaping is preferred for operations like cutting gear segments, cutting, spur gear, herring-bone gears, splines and sprockets etc., of gear shaping over other diameter.

### **7. What are the advantages of gear shaping over the other methods?**

The advantages are:

- a) The finished gear has a generated profile
- b) It is suitable for cutting internal gears
- c) Only one cutter is used for cutting all spur gears of the same pitch.

### **8. Specific types of gears that could be formed specifically by gear shaping process?**

Shaping process can operate on classes of gearing outside the capacity of other methods.

Example is: a) Internal gears with or without back shroud, b) Cluster gears.

**9. Distinguish between gear shaping and gear planning?**

- a) The job is indexed and tool reciprocates
- b) Gear can be generated by using form tool as well as pinion cutter.

- a) Job is indexed and reciprocated but the tool is fixed.
- b) Gear can be produced by means of form tool and Rack cutters.

**10. What is the basic condition to use 'Bobbing' in gears?**

Hobbing can be done only if the gear blank to be generated is of the same modules